



# GERSAN

2014

ELEKTRİK TİC. ve SAN. A.Ş.



## KABLO TAŞIMA SİSTEMLERİ

*Cable Support Systems*

ОПОРНЫЕ КАБЕЛЬНЫЕ СИСТЕМЫ

## KABLO TAŞIYICILARI

*Cable Trays*

Кабельные Лотки





# index

## KABLO TAŞIMA SİSTEMLERİ

ОПОРНЫЕ КАБЕЛЬНЫЕ СИСТЕМЫ

03-108

### Cable Support Systems

NPI-80 DESTEK ELEMANLARI <i>NPI-80 Support System</i>	05-16
U-Z-L-W PROFİL VE KONSOL ASKI SİSTEMLERİ <i>U-Z-L-W Profile and Bracket Hanging Systems</i>	17-28
TİJLE KANAL TAŞIYICI - ÖZEL ASKI SİSTEMLERİ <i>Tray Carriers-Used With Threaded Rods - Special Brackets</i>	29-38
KANAL ÜZERİ PRİZ VE SİGORTA MONTAJ ELEMANI - BORU SİSTEMİ <i>Socket and fuses fixing unit on the tray - Pipe System</i>	39-41
DİKEY T ELEMANLARI <i>Vertical "Tee" Support</i>	42
GRANİT BAĞLAMA ELEMANLARI <i>Granite Mounting Elements</i>	43
KABLO AÇMA APARATI <i>Cable Drum Support Equipment</i>	44
BORU KROŞESİ-LASTİKLİ BORU KELEPÇESİ <i>Pipe Clamps-Pipe Clamps With Rubber Insulation For Threaded Rods</i>	45-46
C PROFİL-PROFİL DESTEK VE BAĞLANTI ELEMANLARI <i>C Profile-C Profile Support and Mounting Elements</i>	47-84
CIVATA TAKIMLARI-ASKI TİJLERİ-ÇELİK DÜBELLER-PLASTİK BANT <i>Screw Sets-Threaded Rods-Steel Anchors-Plastic Strip Protector</i>	85-91
ALÜMİNYUM VE PASLANMAZ KABLO KELEPÇELERİ <i>Aluminium 316L Stainless Cable Cleats</i>	93-104
EMT&CONDUIT BORU SİSTEMLERİ <i>Emt&amp;Conduit Systems</i>	105-113

## KABLO TAŞIYICILARI

Кабельные Лотки

109-300

### Cable Trays

NORMAL TİP KABLO KANALLARI-h=40 mm <i>Normal Type Cable Trays</i>	130-139
AĞIR HİZMET TİPİ KABLO KANALLARI-h=40 mm <i>Heavy Duty Cable Trays</i>	140-145
AĞIR HİZMET TİPİ KABLO KANALLARI-h=50 mm <i>Heavy Duty Cable Trays</i>	146-151
AĞIR HİZMET TİPİ KABLO KANALLARI-h=60 mm <i>Heavy Duty Cable Trays</i>	152-157
AĞIR HİZMET TİPİ KABLO KANALLARI-h=100 mm <i>Heavy Duty Cable Trays</i>	158-163
REDÜKSİYONLAR <i>Reducers</i>	164
MUKAVEMETLİ KABLO KANALLARI <i>Strengthened Cable Trays</i>	165-169
GEMİ TİPİ VE ARMATÜR TİPİ KABLO KANALLARI <i>Marine Type and Lighting Fixture Type Cable Trays</i>	170-171
GEÇMELİ KAPAKLI TİP KABLO KANALLARI VE AKSESUARLARI <i>Cable Tray With Clamping Lid</i>	172-175
PREGALVANİZ TRUNKING SİSTEMİ <i>Quick Fix Pregalvanized Cable Trunking</i>	176-187
KABLO KANAL KAPAKLARI VE KAPAK KELEPÇELERİ <i>Cover For Cable Tray and Cover Clamps</i>	188-189
SEPERATÖR-SONLANDIRMA-SEVİYE AYAR-YÖN DEĞİŞTİRME ELEMANLARI <i>Separator-End Cap-Level Changer-Direction Changer</i>	190-191
PASLANMAZ TİP KABLO KANAL VE AKSESUARLARI <i>Stainless Steel Cable Trays</i>	193-212
ALÜMİNYUM KABLO TAŞIYICILARI VE AKSESUARLARI <i>Aluminium Cable Trays</i>	213-226
C PROFİL BASAMAKLI KABLO MERDİVEN VE AKSESUARI <i>Cable Ladder With C-Profile Rung</i>	227-243
C PROFİL VE KÖŞEBENT İÇİN KABLO KROŞELERİ <i>Cable Crochets</i>	244-245
AĞIR HİZMET TİPİ KABLO MERDİVENLERİ <i>Heavy Duty Type Cable Ladders</i>	246-259
ÖZEL AĞIR HİZMET TİPİ KABLO MERDİVENLERİ <i>Special Heavy Duty Type Cable Ladders</i>	260-267
ŞAFT KAPAĞI <i>Shaft Access Cover</i>	268
GM TİPİ KABLO MERDİVEN VE AKSESUARLARI <i>GM Type Cable Ladders</i>	269-276
TEL KABLO KANAL VE AKSESUARLARI <i>Wire-mesh Cable Ladders</i>	277-291



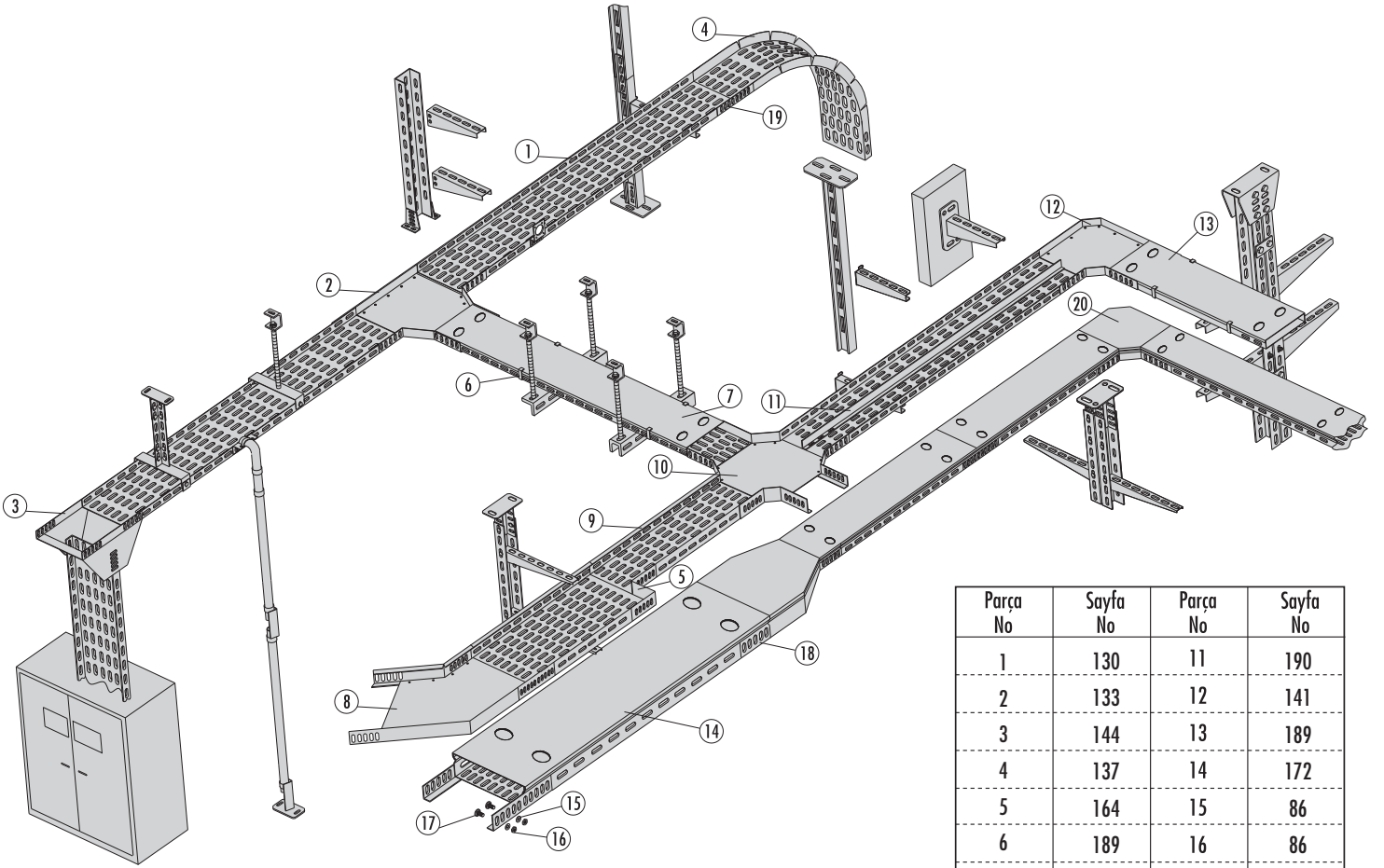

Parça No	Sayfa No	Parça No	Sayfa No
1	130	11	190
2	133	12	141
3	144	13	189
4	137	14	172
5	164	15	86
6	189	16	86
7	189	17	86
8	137	18	172
9	140	19	130
10	135	20	174

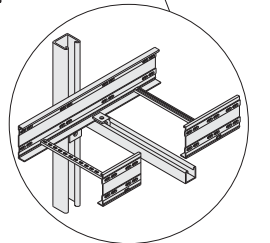
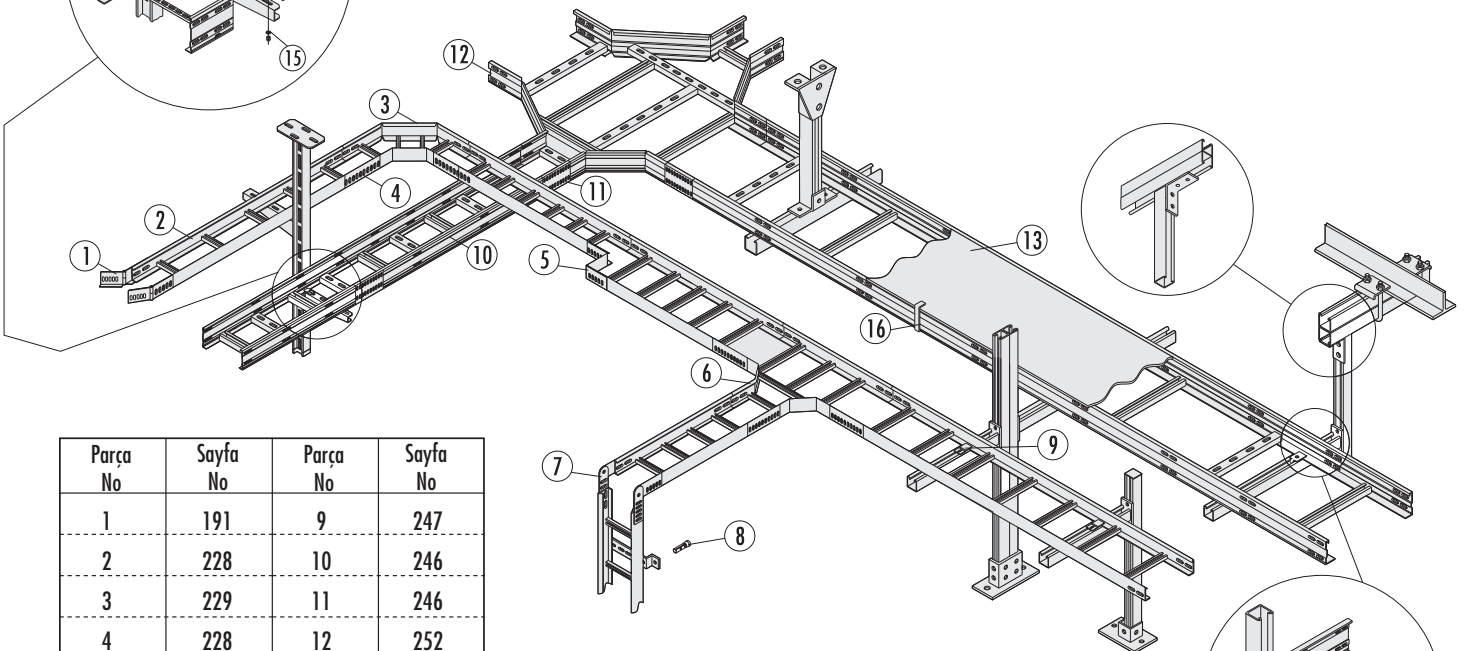
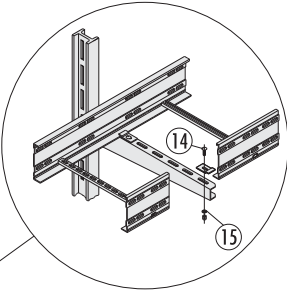

Parça No	Sayfa No	Parça No	Sayfa No
1	191	9	247
2	228	10	246
3	229	11	246
4	228	12	252
5	164	13	189
6	232	14	222
7	191	15	222
8	226	16	189

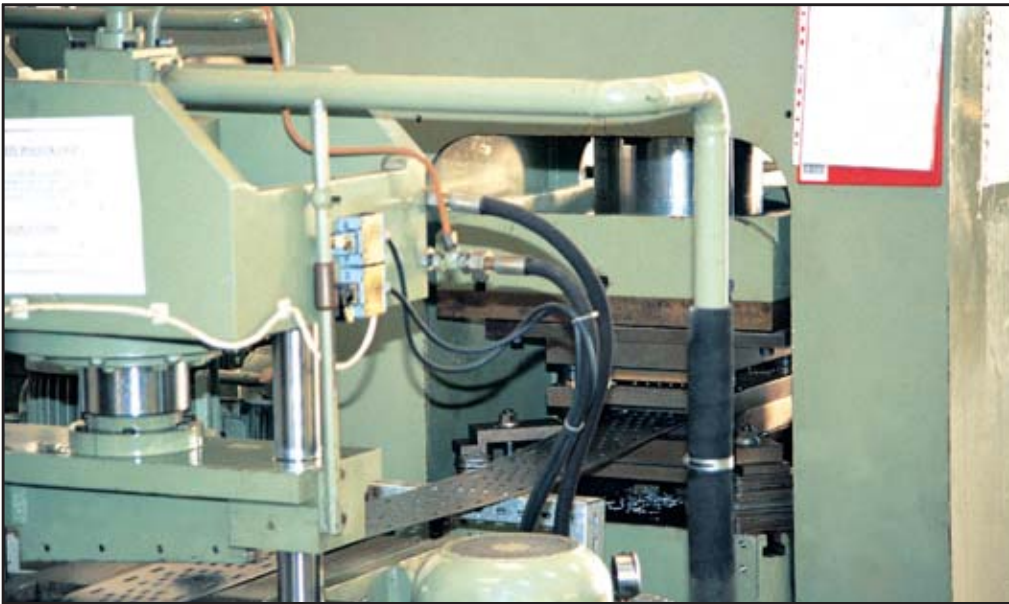
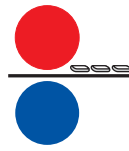

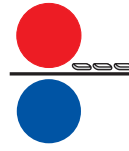

## KATALOĞUMUZU PROJELERİNİZE UYGULAMADA ÖNERİ ve STANDARTLARIMIZ

- Gersan A.Ş. kablo kanal ve merdivenlerini standart 3000mm olarak üretmektedir. 1500mm de bir adet ek elemanı kullanılır. Kablo kanal ve merdivenlerinde bağlantı için GB-2 M8X15 kanal cıvata takımı kullanılır.
- Kablo kanal ve merdivenlerini kesme mecburiyetinde kalırsa mutlaka kesilen yüzeylere zengin çinko ihtiva eden galvaniz boyası uygulanmalıdır.
- Kablo kanal ve merdivenlerinde uygulayacağınız ek elemanları ve cıvata takımı sayıları aşağıda bilgilerinize sunulmuştur.
  - Kenar yüksekliği h=40mm normal tip kanal da G1-1 G1-2 ek elemanı ve 4 adet GB-2 cıvata takımı,
  - Kenar yüksekliği h=40mm ağır hizmet tip kanal da G1-1 G1-2 G1-A ek elemanı ve 4 adet GB-2 cıvata takımı,
  - Kenar yüksekliği h=50mm olan kablo merdivenlerinde G1-3 G1-A1 ek elemanı ve 4 adet GB-2 cıvata takımı,
  - Kenar yüksekliği h=60mm ağır hizmet tip kanal ve merdivenler de G1-4 G1-A2 ek elemanı ve 4 adet GB-2 cıvata takımı,
  - Kenar yüksekliği h=70mm kablo merdivenlerinde G1-A3 ek elemanı ve 4 adet GB-2 cıvata takımı,
  - Kenar yüksekliği h=100mm ağır hizmet tip kanal ve merdivenler de G1-5 G1-A4 ek elemanı ve 8 adet GB-2 cıvata takımı,
- GB-2 cıvata takımları kaplaması standartı elektro galvaniz ve geomet olarak iki çeşittir.
- Kablo kanallarında kullanılan 90° dönüş, "T" bağlantı ve dörtlü bağlantı elemanlarının montajında ek elemanı kullanılmaz. İç-dış bükey elemanları ek elemanı ile bağlanırlar.
- Projelerinizde cıvata takımı hesaplarırken 90° dönüş için 8 adet, "T" bağlantı için 12 adet, dörtlü bağlantı içinde 16 adet GB-2 cıvata takımı hesaplayınız.
- Sipariş verirken aşağıdaki gibi resmini yada A;B;C;D ölçülerini yazarak bildirdiğinizde özel imalat elemanlar yapılır.

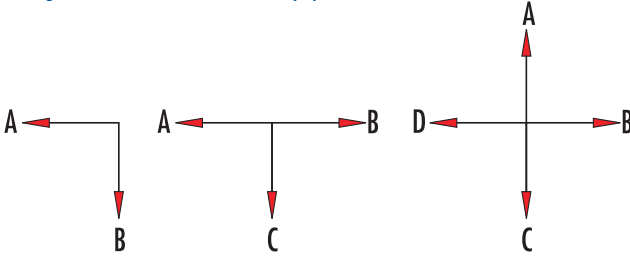

- Kablo merdivenlerinde 90° dönüş, "T" bağlantı, dörtlü bağlantı ve iç-dış bükey elemanları merdiveninize uygun olan ek elemanı ile bağlanır.
- Kablo kanal kapakları (GKT-K) L=3000mm olarak imal edilirler. Kablo kanallarında kullanılan kapaklar, kablo merdivenlerinde de aynı kodla (GKT-K) kullanılırlar.
- Bir adet kapak için 6 adet kapak kelepçesi önerilir. Kapak kelepçeleri kablo kanal veya merdiveninizin kenar yüksekliğine uygun olarak seçilmelidir. Kanallara uygun kapak kelepçeleri aşağıda bilgilerinize sunulmuştur.
  - h=40mm kanallar için GKK-A45 veya GKK-45 kapak kelepçesi
  - h=50mm kanallar için GKK-A55 veya GKK-55 kapak kelepçesi
  - h=60mm kanallar için GKK-A65 veya GKK-65 kapak kelepçesi
  - h=70mm kanallar için GKK-A75 veya GKK-75 kapak kelepçesi
  - h=100mm kanallar için GKK-A105 veya GKK-105 kapak kelepçesi
- Havalandırılmalı kapak kelepçesi kullanılacak olan kapakların delinmesi gereklidir. Kataloğumuzda sizlere h=150mm havalandırılmalı kapak kelepçesi örneği verilmiştir, projenize uygun olarak istenen ölçüde imalat yapmak mümkündür.
- GKK-B tipi kapak kelepçesi sadece ağır hizmet bükümü olan kanallarda kullanılır.

- Seperatörlerin (GES) standart boyu 3000mm dir. Bir adet seperatör en az 3 adet GB-2 cıvata takımı ile bağlanır.
- Seperatör (GES) aynı kodla hem kanallarda hem de merdivenlerde kullanılır.
- Askı sistemlerinde projenizde özel bir ölçü belirtilmemiş ise Gersan A.Ş. size 1500mm de bir askı sistemi önerir.
- Kataloğumuz da sizlere geniş bir askı ve taşıma sistemi sunulmuştur, buna rağmen projenizde özel bir taşıma sistemi detayı mevcut ise ve teknik çizimler tarafımıza bildirilir ise teknolojinin elverdiği ölçüde özel imalat yapmak mümkündür.
- Konsol askı sistemlerinde projede bağlantı elemanı ölçüsü verilmemiş ise Gersan A.Ş. minimum M8 çelik dübel önerir.
- Konsol askı sistemine bağlanacak olan askı konsolunda sizlere cıvatalı veya kopilyalı iki bağlantı şansı verilmiştir, taşıyacağınız yüke uygun olarak seçim yapabilirsiniz.
- Taşıma sistemlerimizden G4 ve G5'lerin standart boyu 3000mm dir. İhtiyaçınız ölçüsünde kesmeniz önerilir fakat kesilen yüzeyin mutlaka zengin çinko ihtiva eden galvaniz boyası ile boyanması gereklidir.
- Tijle kanal taşıma sistemlerinde sizlere tek tij ve çift tij olmak üzere iki alternatif sunulmuştur. Bu sistemlerin uygulanmasında M8 ve M10 tij kullanılır.
- Tijin tavan kısmında kalan ucu, tavana direkt olarak uygun çelik dübel çakılarak monte edilebileceği gibi araya giriş montaj elemanı (GTT) uygulanarak ta montaj yapılabilir.
- Tij siparişlerinizde ihtiyacınız kadar da uygun somun ve pul da sipariş edilmelidir.
- Gersan A.Ş. standardın da tijler elektro galvaniz olarak imal edilir. Standart boyları ise L=500 L=1000 L=2000 L=3000 mm'dir. Standart boyların katlarındaki ihtiyaçlarınız için tij uzatma somunu öneririz. İhtiyaçınız olan diğer ölçülerde de tij imalatı yapmamız mümkündür.
- Kablo kanallarının birleşme yüzeylerinde ve açıkta kalan uçlarında kablonuza zarar gelmemesi için sizlere plastik bant , askı sisteminde kullandığınız NPI demiri ve "C" profil içinde plastik kapak kullanmanızı öneririz.
- Kablo çekme makaraları 300mm ve üzeri kanallarda kullanılır.
- NPI ve NPT demirinden seçilen taşıma sistemlerinde tavana, tabana montajda ve birbirlerine bağlantıda M12 çelik dübel ve cıvata takımı önerilir.
- NPI ve NPT demirinden seçilen taşıma sistemlerinde kullanılan konsollar da montaj için gerekli olan bağlantı klemp ve cıvatası konsolla birlikte verilir.
- Duvar konsollarında sizlere M6'dan M12'ye kadar çelik dübel kullanabilme imkanı sunulmuştur, projenize bağlı olarak dilediğinizi uygulayabilirsiniz.
- Kataloğumuzda sizlere sunulan "C" profillerde her türlü bağlantı, GCCA bağlantı elemanı ile yapılır.
- Geçmeli kapaklı kablo kanalı siparişlerinizde kanal ve kapak birlikte tarafınıza sevk edilir ve kapağın tutturulması için kapak kelepçesi gerekli değildir. Bu tip kanallarda kullanılan ek elemanları şöyledir.
  - h=60mm kanal için h=50 ek elemanı, 4 adet GB-2 cıvata takımı
  - h=70mm kanal için h=60 ek elemanı, 4 adet GB-2 cıvata takımı
  - h=100mm kanal için h=85 ek elemanı, 8 adet GB-2 cıvata takımı
- GM kablo merdivenlerinde kablonuzu bağlamak için kablo bağı kullanılır.
- GMI kablo merdivenlerinde kablonuzu ister kablo bağı isterseniz de kablo kroşesi (KKA) ile bağlayabilirsiniz.
- 180 ve 240mm döşeme altı kanalında GDK-01 buat 300mm kanalda GDK-31 buat kullanılır. Döşeme altı buatların GDK-01 Buatlarda 8 adet priz GDK-31 Buatlarda 12 priz bağlama imkanı vardır
- Katalogda belirtilen malzeme ağırlıkları yaklaşık değerler olup  $\pm 5\%$  toleranslıdır. Ölçüler mm olarak verilmiştir.
  - 5mm'den küçük ölçülerde tolerans  $\pm 0.5$
  - 5mm-1000mm arası ölçülerde  $\pm 2$  mm
  - 1000mm'den büyük ölçülerde  $\pm 5$  mm





## GERSAN Catalogue Suggestions And Standards, For Your Installations In The Projects.

-Gersan manufactures the cable trays and ladders in 3000mm standard length. Two pieces of jointing pieces should be applied for 3000mm length. The screw set GB-2 (M8X15), should be preferred for the jointing piece.

-If the cable trays or ladders should be cut on site, rich zinc paint should be applied on the cutted surfaces.

-The jointing piece and screw set calculation quantities are listed below for cable ladders and trays.

.G1 or G1-2 jointing piece and 4 pieces of GB-2 screw sets should be chosen for the cable trays with 40mm height as defined our medium duty standard tray.

.G1 or G1-2 or G1-A jointing piece and 4 pieces of GB-2 screw sets should be chosen for the cable trays with 40mm height as defined our heavy duty tray.

.G1-3 or G1-A1 jointing piece and 4 pieces of GB-2 screw sets should be chosen for the cable ladders with with 50mm height .

.G1-4 or G1-A2 jointing piece and 4 pieces of GB-2screw sets should be chosen for the heavy duty cable ladders with with 60mm height .

.G1-A3 jointing piece and 4 pieces of GB-2screw sets should be chosen for the heavy duty cable ladders with 70mm height.

.G1-5 or G1-A4 jointing pieces and 8 pieces of GB-2 screw sets should be chosen for the heavy duty cable trays and ladders with 100mm height.

-The coating standard for GB-2 screw sets are electro galvanisation or geomet coating.

-Jointing pieces are not required to joint 90° benders, 'T' elements or crossing parts. Only internal or external risers do require jointing pieces.

-The required screw sets are : 8 pieces for 90° benders, 12 pieces for T elements, 16 pieces for the crossing parts ;to be calculated in your projects.

-Special products may be manufactured ,if you send us the technical drawings as shown below with the dimensions of A.B.C.D.

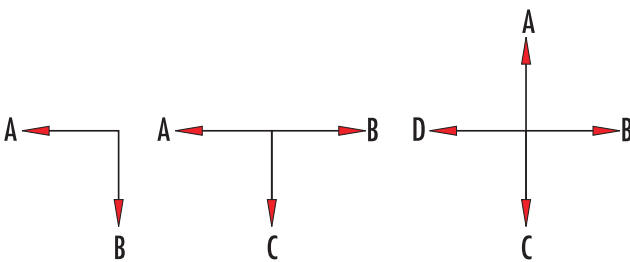

-The proper jointing pieces should be chosen when you purchase 90°bends, 'T' elements, Crossing pieces or internal-external reducers.

-The cable tray covers (GKT-K) are manufactured in 3000mm length. The covers do fit to both cable ladders and cable trays, and the reference no for covers start with (GKT-K).

-Gersan recommends 6 pieces of clipses for each cover. These clipses should be chosen regarding the height of your tray's or ladder's height. The clipses are shown below for the correct choice.

.GKK-A45 or GKK-45 clipses for the trays or ladders with 40mm height.

.GKK-A55 or GKK-55 clipses for the trays or ladders with 50mm height.

.GKK-A65 or GKK-65 clipses for the trays or ladders with 60mm height.

.GKK-A75 or GKK-75 clipses for the trays or ladders with 70mm height.

.GKK-A105 or GKK-105 clipses for the trays or ladders with 100mm height.

-Gersan also manufactures ventilated type cover clipses. These clipses have 150mm height to avoid the cables over-heating in the trays or ladders. The covers for these clipses should be slotted for installation.

-GKK-B type cover clipses should only be purchased for heavy duty type trays.

-The seperators(GES) are manufactured in 3000mm length.Each piece will be installed with 3 pieces of GB-2 screw sets.

-The seperators(GES) might be chosen for both, cable trays and ladders.

-If the hanging element is not specified in your project,Gersan offers you the hanging element in each 1500mm for the optimum installation.

-Gersan offers a wide range of hanging elements in our catalog.But if you request a special type,Gersan will manufacture the new type regarding your request if possible.

-If the anchoring bolt is not specified in the project,Gersan offers you minimum M8 for the installation of the brackets.

-Gersan offers you two types of bracket installation figures.These are the screw type or anchor type.You may choose either of them depending on the load that will apply on them.

-The standard length of (G4) is 3000mm which is our standard hanging element.We recommend you to cut it in your prefered length.But please remember that,the cutted surface should be re-coated with the rich zinc paint on the site.

-Gersan offers you two types of hanging with the hanging rods.These are single type or the double type.M8 and M10 hanging rods will be purchased for these elements.

-The hanging rods may be installed directly to the ceiling.Or you may choose a ceiling installation bracket (GTT) to mount.

-You should also order nuts and washers for the installation of the hanging rods.

-Gersan manufactures the hanging rods as electro galvanised in our standard.The standart lengths are 500,1000 or 2000mm.We recommend you,a jointing nut to mount two hanging rods to each other.We may also manufacture the hanging rods in your requested lengths.

-Cable Drum Macarons may only be installed for the racks over 300mm width.

-The supports which will be installed with NPI or NPT irons,should be ordered with M12 concrete anchors for the installations to the wall,ceiling or to each other.

-The bracket which will be supplied with NPI or NPT irons,will be supplied with the necessary clamps and bolts.

-You may purchase concrete anchors between M6-M12,depending on your choice,for the wall brackets .

-The C profiles in our catalog,may only be installed with the GCCA part ,for all types .

-The tray types which are covered,are manufactured with a clamping method.At the result of this method,you do not need clipses to mount the covers on trays.You will find the types of jointing pieces listed below.

.Jointing piece (h:50),and 4 pcs of GB-2 should be chosen for cable trays with 60 mm height.

.Jointing piece (h:60),and 4 pcs of GB-2 should be chosen for cable trays with 70 mm height.

.Jointing piece (h:85),and 4pcs of GB-2 should be chosen for cable trays with 100mm height.

-Cable stripes should be required to install your cable in GM type cable ladders.

-You may install your cable with cable stripes or with cable crochet(KKA) in GMI type cable ladders.

-For underfloor cable trunking,you should choose GDK-01 floor box.Or you should choose GDK-05 floor box for 300mm width tray.You may install 8 pieces of sockets for GDK-31.

-The kilograms listed in our catalog,may differ %±5 in tolerances.

The dimensions are supplied in mm.

The tolerance is %5 for the dimensions below 5mm.

The tolerance is ± 2mm for the dimensions between 5mm-1000mm.

The tolerance is ± 5mm for the dimensions over 1000mm.

## Наши предложение и стандарты

- 1- GERSAN производит кабельные и лестничные лотки в 3000мм стандартная длина. В каждом 1500мм используется один соединительный элемент. Набор винта устанавливает GB-2 (M8x15), используется для соединения в кабельных лотков.
- 2- Если кабельные и лестничные лотки сокращены, цинковая краска должна примениться на поверхности отрезка.
- 3- Количество соединительный элемента и набора винта внесено в список ниже для кабельных и лестничных лотков :
  - Кабельные лотки нормального типа, h=40 мм :
  - Соединительные элементы «G1-1» или «G1-2» ; 4 штуки наборы винта-«GB-2»
  - Сверхмощные кабельные лотки, h=40 мм : Соединительные элементы «G1-1» или «G1-2» или «G1-A» ; 4 штуки наборы винта-«GB-2»
  - Кабельные лестничные лотки, h=50 мм : Соединительные элементы «G1-3» или «G1-A1» ; 4 штуки наборы винта-«GB-2»
  - Сверхмощные кабельные лотки и лестничные лотки, h=60 мм : Соединительные элементы «G1-4» или «G1-A2» ; 4 штуки наборы винта-«GB-2»
  - Кабельные лестничные лотки, h=70 мм : Соединительные элементы «G1-A3» ; 4 штуки наборы винта-«GB-2»
  - Сверхмощные кабельные лотки и лестничные лотки, h=100 мм : Соединительные элементы «G1-5» или «G1-A4» ; 8 штук наборы винта-«GB-2»
- 4- Есть два стандарта покрытия для винта «GB-2» электрогальванизируют покрытие и Дакромет покрытие.
- 5- Соединительные элементы не требуются к 90 углов, «Т» образные соединительные элементы и крестообразные соединительные элементы. Только Внутренние и внешние вертикальные угловые элементы требуют соединительный элементый.
- 6- Угловые элементы 90° : 8 штук наборы винта-«GB-2»
  - «Т» образные соединительные элементы : 12 штук наборы винта-«GB-2»
  - Крестообразные соединительные элементы : 16 штук наборы винта-«GB-2»
- 7- Специальные изделия могут быть изготовлены, если вы посылаете нам технические рисунки как показано ниже с измерениями A,B,C,D.

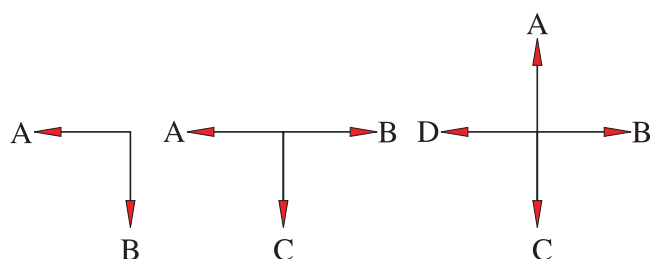

- 8- Крышки для кабельных лотков «GKT-K» изготовлены в 3000мм длина. Та же самые покрытия используются в кабельные лестничные лотки.
- 9- 6 штук фиксаторы используются для каждого крышка. Фиксаторы показывается ниже для правильного выбора.
  - Лотки , h=40 мм : Фиксатор «GKK-45» или «GKK-A45»
  - Лотки , h=50 мм : Фиксатор «GKK-55» или «GKK-A55»
  - Лотки , h=60 мм : Фиксатор «GKK-65» или Сепараторы
  - Лотки , h=70 мм : Фиксатор «GKK-75» или «GKK-A75»
  - Лотки , h=100 мм : Фиксатор «GKK-105» или «GKK-A105»
- 10- GERSAN также производит проветренный (вентиляционных) тип, закрывающие фиксаторы и требуемые длины могут быть изготовлены. h=150 мм проветренный (вентиляционных) тип закрывающие фиксаторы пример, сданный GERSAN каталог. Крышки для этих фиксаторы должны быть выдолблены для

- установки.
- 11- «GKK-B» тип закрывающие фиксаторы только используется для сверхмощных кабельных лотков.
- 12- Сепараторы «GES» изготовлены в 3000мм длина. Каждая штука будет установлена с минимумом 3 штуки наборы винта «GB-2» .
- 13- Сепараторы «GES» могли бы быть выбраны для кабельных лотков и лесниц.
- 14- Если висящий элемент не определен в вашем проекте, GERSAN предлагает вам один висящий элемент в каждом 1500мм для оптимальной установки.
- 15- Если вы просите специальный тип, GERSAN произвел новый тип относительно вашего запроса если возможно.
- 16- GERSAN предлагает вам минимальный M8 стальной дюбель для установки скобок.
- 17- GERSAN предлагает вам два типа установки скобки. Они-тип винта или тип якоря (шпилька). Вы можете выбрать любой из них в зависимости от груза, который применится на них.
- 18- Стандартная длина «G4»-3000мм, который является нашим стандартом, система консольных подвесок. Мы рекомендуем вам сокращает это в вашей предпочтительные длине, цинковая краска должна примениться на поверхности отрезка.
- 19- Шпильки могут быть установлены непосредственно к потолку или вы можете выбрать скобку установки потолка «GTT», чтобы повыситься.
- 20- Вы должны также приказать сходить с гайкой и шайбой для установки шпильки.
- 21- GERSAN производит шпильки как электрогальванизированный в нашем стандарте. Стандартные длины-500, 1000 или 2000мм. Мы рекомендуем вам удлиненная гайка установит два шпильки к друг-друга. Мы можем также производить шпильки в ваших требуемых длинах.
- 22- Катушка для протягивания кабеля может толка использовать для лотка это по 300мм ширина.
- 23- Консоли, которые будут установлены с NPI или NPT железом, нужно заказывать с M12 бетонными дюбелями для сооружений к стене, потолку или к друг-друга.
- 24- Консоли, которые будут с NPI или NPT железом, будут снабжена необходимыми клеммами и винтами.
- 25- Вы можете купить бетонная дюбель между M6 и M12, в зависимости от вашего выбора, для стенных консоли.
- 26- С профили в нашем каталоге, могут только быть установлены с GCCA соединительных элементов для всех типов.
- 27- Типы кабельных лотков с выдвигающейся крышкой : Не нуждается фиксатор, чтобы установить крышка на лотках. Количество соединительный элемента и набора винта внесено в список ниже для кабельных лотков с выдвигающейся крышкой :
  - h=60 мм : Соединительные элементы h=50 ; 4 штуки наборы винта-«GB-2»
  - h=70 мм : Соединительные элементы h=60 ; 4 штуки наборы винта-«GB-2»
  - h=100 мм : Соединительные элементы h=85 ; 8 штук наборы винта-«GB-2»
- 28- Подпольные кабельные каналы :
  - GDK-18 : Пустая распределительная коробка GDK-01
  - GDK-24 : Пустая распределительная коробка GDK-01
  - GDK-30 : Пустая распределительная коробка GDK-31
- 29- Вы можете устанавливать 8 штук розетки в GDK-01 и GDK-31
- 30- Килограммы, внесенные в список в нашей каталоге, могут отличаться 5 процентов в терпимости. Измерения сданный "мм".
  - Терпимост 5% для измерений ниже 5мм
  - Терпимост ±2мм для измерений между 5мм и 1000мм
  - Терпимост ±5мм для измерений по 1000мм



## SICAK DALDIRMA GALVANİZ ( TS 914 EN ISO 1461'e göre) *Hot dip galvanization (Regarding TS 914 EN ISO 1461)*

### Галванизация (оцинковывания) горячего погружения (Согласно стандарта TS 914 EN ISO 1461)

Dayanıklılık açısından en ideal kaplama şeklidir. İlk olarak 1742 yılında Fransız kimyacı Meloin demirin ergimiş çinko banyosuna daldırılarak çinko kaplama elde edildiğini tanımladı. 1830 yılında İngiltere ve Fransa'da proses geliştirildi. 1980 yılında Gersan A.Ş. kendi tesislerini (7500x1250x2000 mm ölçülerinde) açarak bugüne kadar sıcak daldırma galvaniz endüstrisini gelişmiş ülkelerde olduğu gibi ülkemizde de kullanımını yaygınlaştırmak amacı ve ülke kaynaklarının korozyona karşı korunarak ekonomik kullanılmasına katkıda bulunmuştur.

#### Avantajları:

- a) **Düşük Maliyet** : Büyük partiler halinde bir çok parçanın kısa zamanda daha az iş gücü ile düşük maliyetle, alternatif kaplamalara göre karşılaştırıldığında ucuz olduğu görülür.
- b) **Düşük Servis Maliyeti** : En az 30 yıl bakım ve onarım gerektirmeden kullanılır. Üretimin durması mümkün olmayan, ulaşması zor yerlerde onarım yapma problemi ortadan kalkar.
- c) **Uzun Ömür** : Deniz suyu içinde 10-15 yıl en ağır endüstriyel bölgelerde 15-20 yıl normal atmosferik şartlarda 40 yıl ömrü vardır.
- d) **Uygulama Hızı** : Galvaniz 5-10 dakikada elde edilirken 4 kat boya işlemi için bir haftalık süreye ihtiyaç vardır.
- e) **Güvenilirlik** : Kaplama kalınlığı tam ölçüldüğü için ömrü önceden tahmin edilir. Yıllık çinko kaybı şehirleşmemiş ortamda 1.5µm şehirleşmiş ortamda 4µm deniz kenarında 5.5µm Endüstriyel ortamda 5-10 µm dur.
- f) **Kaplama Tokluğu** : Çelikte yapılarak metalurjik bağ kurabilen kaplama prosesidir. Bundan dolayı taşıma, depolama, sevkiyat ve montajda mekanik hasarlara karşı dirençlidir.
- g) **Bütünsel Kaplama** : Malzemenin içi , dışı , köşe ve yüzeyleri dahil tüm yüzeyi başka şekilde korozyona karşı korunması mümkün olmayan bütünü, çinko ile kaplanır.
- h) **Üç Yönlü Koruma** : Çelik, sıcak daldırma yöntemi ile üç yönlü korunur. Birincisi çinkonun yavaş yavaş kendini feda etmesi, ikincisi mekanik hasarlarda çinko tarafından oluşturulan korozyon ürünlerinin oluşturduğu koruma, üçüncüsü hasar gören bölge daha büyük olduğunda çinko kaplamanın, çeliğe göre daha elektro negatif olmasından dolayı çelikten önce korozyona uğrayarak çeliği korumasıdır..
- i) **Kalite Kontrollerde Kolaylık** : Sıcak daldırma galvaniz kaplama (ASTM-A-123, BS EN ISO 1461, DIN 50976, TS 914 EN ISO 1461 standartlarına uygun olarak yapılıp yapılmadığının kontrolüdür. Testler dijital kaplama kalınlığı ölçme cihazı veya tahribatsız muayene ölçüm aletleriyle kolayca yapılıp standartlara uygunluğu karşılaştırılır.
- j) **Hızlı Montaj**: Kaplanmış çelik montaja hazırdır.
- k) **Korozyon**: Kaplama yapılmış malzeme havanın oksijeni ile ilk korozyona uğrayarak mat gri renkte koruyucu bir çinko tabakası oluşturur. Taşıma ve depolama esnasında beyaz pas oluşumunu önlemek için malzemenin her tarafından hava almasını sağlayacak şekilde palet üzerinde istiflenmesi gerekir.

l) TS 914 EN ISO 1461 ve BS EN ISO 1461 Standartlarına göre olması gereken kaplama ağırlıkları:

TS 914 EN ISO 1461	Malzeme kalınlığı mm Thickness (mm) Толщина материала	Yerel Kaplama Ağırlığı (en az) <sup>a</sup> µm	Ortalama Kaplama Ağırlığı (en az) <sup>b</sup> µm
E	Çelik (Steel) ≥ 6mm	70	85
N	Çelik (Steel) ≥ 3 < 6 mm	55	70
I	Çelik (Steel) ≥ 1.5mm - < 3 mm	45	55
S	Çelik (Steel) < 1.5mm	35	45
0	Dökümler ≥ 6mm	70	80
1	Dökümler < 6mm	60	70
4	Malzeme kalınlığı mm Thickness (mm) Толщина материала	Lokal Kaplama Kalınlığı (µm) minimum Local coating thickness (µm) minimum Местная толщина покрытия (µм)-мин.	Ortalama Kaplama kalınlığı (µm) minimum Mean coating thickness (µm) minimum Средняя толщина покрытия (µм)-мин.
6	Çelik (Steel) ≥ 6mm	70	85
1	Çelik (Steel) ≥ 3 < 6 mm	55	70
4	Çelik (Steel) ≥ 1.5 < 3 mm	45	55
1	Çelik (Steel) < 1.5 mm	35	45

*This is the ideal way of coating against corrosion. This method has been invented by French chemist called MELOIN by deeping iron in to the liquid zinc bath. The process has been developed in France and in England. GERSAN has owned a hot dip galvanization oven (dimension: 7500x1250x2000) from the day of establishment. Gersan's goal is to make hot dip galvanization prevalent also in Turkey as other developed countries and to protect Turkish steel products and to develop the Turkish economy.*





*The advantages are: time with lower working hours and lower costs.*

*b) Lower Maintenance Costs: Hot dip galvanized materials are good for over 30 years without any need of service. This makes hot dip galvanization method the best because this avoids the plants to stop production, offers the plants to avoid hard re-installations or re-maintenance.*

*c) Longer Life Time: Hot dip galvanization offers a life time of 40 years in normal atmospheric conditions, 15-20 years in heavy industrial zones and 10-15 years in salty sea water.*

*d) Faster Application: Hot dip galvanization is applied only for about 5 minutes. If painting is chosen, for 4 layers of painting it will take about a week.*

*e) Reliability: Life time of the material can be guessed in the beginning because the thickness of the coating can completely be measured. Annual zinc loss is 1,5 µm in country areas, 4 µm in cities, 5,5 µm in sea side and 5-10 µm in the industrial zones.*

*f) Coating Satisfaction: This is the coating process which zinc is adhered to the steel and has a metallurgical bond. This is the reason that hot dip galvanized products have better strength against the shocks or etc. while carrying, stocking, delivering and installing.*

*g) Full Surface Coating: The products inner areas, outer areas, corners and all surfaces are coated in a way which is not available in other coating processes.*

*h) 3 Way Protection: Steel is protected in 3 ways by hot dip galvanizing. First; zinc gets out slowly but protects the steel. Second; if a mechanical damage occurs, steel is protected by the corrosion products of zinc. Third; in the case of larger damaged areas, zinc coating starts to corrode first because zinc is more electronegative than steel, and protects steel from corrosion.*

*i) Easy Quality Control: It is the control of the hot dip galvanization coating whether the product is confirming the standards (ASTM-A123, BS-1461, DIN 50976, TS 914 EN ISO 1461). The tests are applied by digital coating thickness measurement devices or mechanical inspection devices easily. And it's easy to compare the measurement results with the standards.*

*j) Fast Installation: Hot dip galvanized products are ready to install.*

*k) Corrosion: Hot dip galvanized products react with the oxygen in the atmosphere and a dull gray colored protective zinc layer occurs. In order to protect from white corrosion, products should be stored on pallets for gathering full air from all sides.*

*l) The Necessary Weights of Coating According to TS 914 EN ISO 1461 and BS EN ISO 1461 Norms are shown on the table*

## Горячее Цинкование Методом Окунация (Согласно стандарта TS 914 EN ISO 1461)

Представляем идеальный способ нанесения антикоррозионного покрытия. Данный метод был изобретен Французским химиком Мелоном и состоит в погружении железа в ванну с жидким цинком. Этот процесс получил свое дальнейшее развитие во Франции и Великобритании. Фирма GERSAN владеет печью для оцинковывания путем горячего погружения (ее размеры 7500x1250x2000 mm) со дня своего основания. Фирма GERSAN ставит своей целью достижение превосходства метода оцинковывания путем горячего погружения в Турции наряду с другими развитыми странами, и защищение таким образом Турецкие изделия из стали, и следовательно, способствуют развитию экономики Турции. Преимущества метода заключаются в следующем :

**1-Более низкая стоимость.** Ее можно вычислить путем сравнения альтернативных методов нанесения покрытия, за счет одновременного нанесения покрытия на большее количество изделий, путем уменьшения затраты рабочих часов, и более низкой себестоимости процесса.

**2-Более низкая стоимость.** Изделия оцинковываемые методом горячего погружения служат более 30 лет и не нуждаются в дополнительном обслуживании. Этот факт делает метод оцинковывания путем горячего погружения самым лучшим, поскольку позволяет производственным предприятиям избежать остановки производства в целях серьезной замены оборудования и технического обслуживания.

**3-Более длительный период эксплуатации.** Метод оцинковывания путем горячего погружения предлагает 40 лет эксплуатационного периода при нормальных условиях окружающей среды; 15-20 лет- в зонах тяжелой индустрии и 10-15 лет в условиях воздействия соленой морской воды.

**4-Надежность.** Процесс оцинковывания методом горячего погружения длится всего около 5 минут. При необходимости покраски изделия, для 4-х слойной покраски потребуется всего около нади.

**5-Более быстрое применение.** Период эксплуатации изделия должен быть оговорен до начала процесса, поскольку можно полностью задать толщину покрытия. Годовая потеря цинка в сельской местности равна 1.5µm, в городах 4 µm, на море 5.5µm, в промышленных зонах 5-10µm.

**6-Качества покрытия.** При данном процессе нанесения покрытия, цинк связывается со сталью и образует металлургическое соединение. Именно поэтому изделия оцинковываемые методом горячего погружения обладают большей устойчивостью к ударам и прочим внешним механическим воздействиям, например, во время транспортировки, хранения, доставки или монтажа.

**7-Нанесение покрытия на всю поверхность.** При данном методе подвергаются оцинковке внутренняя поверхность изделия внешняя поверхность, углы и выступы, что невозможно достичь другими методами нанесения покрытия.

**8-Три способа защиты.** При оцинковывании горячим погружением, сталь приобретает 3 способа защиты. Первый, несмотря на медленную потерю цинка, он защищает сталь. Второй, в случае возникновения механических повреждений, продукты коррозии цинка защищают сталь. Третий, в случае возникновения повреждений на больших площадях, цинк скорее подвергается коррозии поскольку он более электроотрицательный чем сталь, и таким образом защищает сталь от коррозии.

**9-Доступный контроль качества.** Он состоит в контроле покрытия методом горячего погружения на предмет его соответствия следующим стандартам: ASTM-A-123, BS EN ISO 1461, DIN 50976, TS 914 EN ISO 1461 Данный контроль осуществляется посредством цифрового прибора по измерению толщины нанесенного покрытия или механического исследования покрытия. Полученные результаты измерения легко сопоставить с выше указанными стандартами.

**10-Быстрая установка.** Изделия, оцинковываемые методом горячего погружения, готовы к установке.

**11-Коррозия.** В результате взаимодействия с кислородом, содержащемся в атмосфере, изделия, оцинковываемые горячим погружением, приобретают тускло серый свет. Чтобы защитить изделия от белой коррозии, их следует хранить на поддонах, обеспечив тем самым свободный доступ воздуха со всех сторон.

12-Необходимый вес покрытия в соответствии с нормами TS 914 EN ISO 1461, приведен в таблице.



**İSTANBUL TEKNİK ÜNİVERSİTESİ**  
MALZEME BİLİMLERİ VE ÜRETİM TEKNOLOJİLERİ  
UYGULAMA ARAŞTIRMA MERKEZİ

Sayı: IKT.12.10.2001/3E-111E  
TARİHİ: 18.05.2001

RAPOR

**GERSAN ELEKTRİK TİC. ve SAN. A.Ş.** Yarı 14.05.2001 tarihli yapılan bir gelen örneğine ilişkin rapordur.

**Özellikler:** Yüzeyinde galvaniz ve galvaniz banyosundan alınan çirko örneği ve kesimden banyosundan alınan HCl asit çözeltisi örneği olduğu belirtilmiştir.

**İstenenler:** Çirko örneğinin kimyasal bileşiminin ve HCl asit çözeltisinin kimyasal bileşiminin belirlenmesi.

**Bulgular:** Yapılan deney ve analizlere aşağıdaki sonuçlar elde edilmiştir:

a) Çirko örneğinin kimyasal bileşimi:

Element	%	Element	%
Zn	98,72	Al	0,214
Pb	0,83	Cd	0,0112
Fe	0,220	Sn	0,49
Cu	0,005		

b) HCl asit çözeltisinin kimyasal bileşimi: 19

örnek bulunmamaktadır. Bilginiz için teşekkür ederiz.

*(dimension: 7500x1250x2000)*

Doç. Dr. M. Kınacı GÖZGEN

*(Signature)*  
Ortaokul Prof. Dr. Çiğdem AKDEMİR  
Merkez Müdürü

No: 100110 300 00 01 144-01010 300 00 00 Fax: 0010 300 20 49  
E-Posta: iletisim@itkmmg.com.tr  
AKININ İÇİ BAĞIŞIĞI KARPUZLU BAĞIŞIĞI - İSTANBUL

SICAK DALDIRMA GALVANİZ KAPLAMA TESİSİMİZİN,  
GALVANİZ POTASI (1100x1500x6500 mm) EBADINDADIR.



Üzerine marka vurulmasına müsait. Tüm ürünlerimizde GERSAN markası vardır.  
*It is convenient to stick the mark. All our products have GERSAN sticker.*

Расположен для Маркировки. Вся наша продукция маркирована "GERSAN"





## PREGALVANİZLİ SICAK DALDIRMA (TSE-822'ye göre) *Hot Dip Pregalvanized Products (Regarding TSE-822 standart)*

ГОРЯЧЕЕ ЦИНКОВАНИЕ С ПРЕДВАРИТЕЛЬНЫМ ЦИНКОВАНИЕМ (СОГЛАСНО СТАНДАРТАМ TSE-822)

Pre Galvaniz yöntemiyle kaplama 15-25 µm arasındadır. Kuru iç mekânlarda korozyona karşı yeterli koruma sağlar. 1,2 mm kadar sac kalınlıklarında, kesme ve delme kenarlarında sac ile çinko arasında pil oluşarak katodik koruma yapabilir. Buda kesim yerlerinde azda olsa sacın çürümesine engel olur. Kuru iç ortamda çinko kaybı yıllık 0-3 mikron, rutubetli iç ortamlarda çinko kaybı yıllık 2-3 µm kimyasal ve asitli ortamlarda çinko kaybı yıllık 4-5 µm'dur.

*Pre Galvanizing method offers a coating thickness between 15-25 µm's. This method offers enough protection against corrosion for indoor use. Cathodic protection is obtained by means of battery effect between steel and zinc on the cutted edges for thicknesses up to 1,2 mm. This avoids corrosion, though the prevention is not so strong. Zinc loss is 0-3 µm in indoor dry areas annually, 2-3 µm in moistured areas annually. If the materials are to be used in chemical or acidic areas, zinc loss is 4-5 µm annually.*

При нанесении толщина предварительного гальванизированного покрытия составляет 15-25 микрон. Этот метод главным образом способствует предотвращению появления коррозии на сухих внутренних рабочих поверхностях. Катодная защита выполняется толщиной 1,2мм на стальных листах, срезанных и сколотых краях между стальным и цинковым листом гальванического элемента. Это препятствует появлению коррозии, хотя и не слишком сильно. Потеря цинка на сухих внутренних поверхностях ежегодно составляет 0-3 микрон, на влажных поверхностях 2-3 микрон в год и на поверхностях, которые используются в химической и кислотной среде эта потеря составляет 4-5 микрон в год.





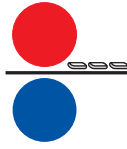

## PASLANMAZ ÇELİK (304 veya 316 kalite Krom -Nikel ) *Stainless Steel 304 or 316 quality standart Cr-Ni)* Нержавеющая Сталь Марки AISI 304 и 306



**GERSAN A.Ş.** özel uygulamalarda kanalları, ek parçalarını ve civataları paslanmaz çelikten (Krom- Nikel) yapar. Daha çok yiyecek ve içecek endüstrisinde kullanılır. Hijyenik ortam sağlar.

*GERSAN A.S. manufactures trays, accesories and jointing elements from stainless steel in special projects. Stainless steel trays are optained generally for food and beverage sector. Stainless steel trays provides hygienical surroundings.*

АО «GERSAN A.Ş.» осуществляет производство поддонов специального назначения, дополнительных частей и стыковочных элементов из нержавеющей стали [хромоникелевого сплава]. В основном материалы используются в пищевой промышленности и в производстве по изготовлению напитков. Все изделия из нержавеющей стали обеспечивают защиту с точки зрения гигиены.

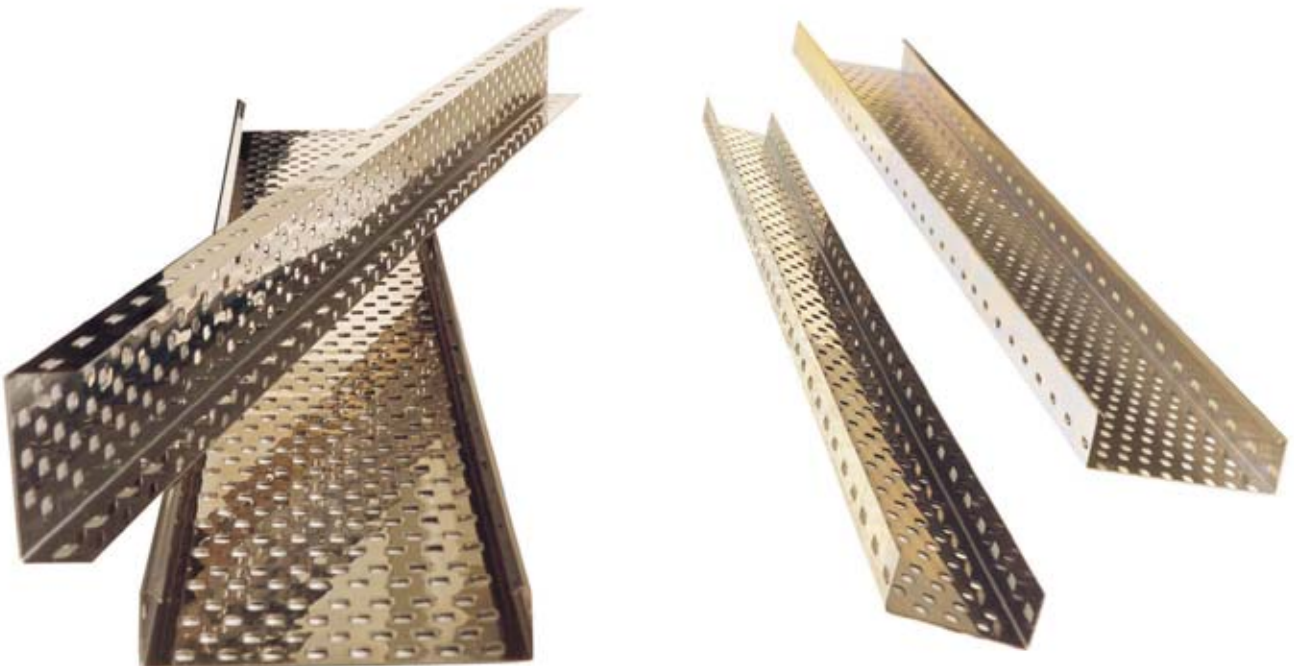

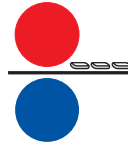

## ALÜMİNYUM KABLO KANAL VE MERDİVENLERİ Aluminium cable trays and ladders

Алюминиевые Кабельные Лотки и Лестничные Лотки

Kablo kanallarının ve merdivenlerinde kullanılan alüminyum malzemelerin teknik özellikleri	Technical Characteristic of aluminium material used in cable trays and cable ladders:	Технические характеристики алюминиевых материалов, использованных для кабельных лотков и лестниц.
<p>Alaşım : 5052 Kondisyonu : H12 Çekme Mukavemeti : 160-260 N/mm<sup>2</sup> Akma Mukavemeti : 160 N/mm<sup>2</sup> Sertlik : 63 HB Kalınlık : 1.5-3 mm Uzama : L<sub>0</sub> 50mm%6 Std : Almg Si 2.5</p>	<p>Aluminium Alloy : 5052 State : H12 Tensile Strength : 160-260 N/mm<sup>2</sup> Yield Strength : 160 N/mm<sup>2</sup> Brinell Hardness : 63 HB Thickness : 1.5-3 mm Elongation : L<sub>0</sub> 50mm%6 Standard : Almg Si 2.5</p>	<p>Алюминиевый сплав : 5052 Структура : H12 Предел прочности на разрыв : 160-260 N/mm<sup>2</sup> Предел текучести : 160 N/mm<sup>2</sup> Твёрдость : 63 HB Толщина : 1.5-3 mm Удлинение : L<sub>0</sub> 50mm%6 Стандарт : Almg Si 2.5</p>
<p>Alaşım : 6063 Çekme Mukavemeti : 150-215 N/mm<sup>2</sup> Akma : 70-190 N/mm<sup>2</sup> Sertlik : 43-67 HB Kalınlık : 1.5-2.5 mm Uzama : L<sub>0</sub> 50mm%10-23 Standart : Almg Si 0.5</p>	<p>Aluminium Alloy : 6063 Tensile Strength : 150-215 N/mm<sup>2</sup> Yield Strength : 70-190 N/mm<sup>2</sup> Brinell Hardness : 43-67 HB Thickness : 1.5-2.5 mm Elongation : L<sub>0</sub> 50mm%10-23 Standard : Almg Si 0.5</p>	<p>Алюминиевый сплав : 6063 Предел прочности на разрыв : 150-215 N/mm<sup>2</sup> Предел текучести : 70-190 N/mm<sup>2</sup> Твёрдость : 43-67 HB Толщина : 1.5-2.5 mm Удлинение : L<sub>0</sub> 50mm%10-23 Стандарт : Almg Si 0.5</p>

Katalogumuzda belirtilen alüminyum kablo kanal ve merdivenleri EN 6063 Standartında malzemeden üretilir.

Bu ürünlerde kullanılan ve katalogumuzda sıcak daldırma galvaniz olarak belirtilen tüm ürünler EN 5052 standartındaki alüminyum malzemeden üretilir.

*Cable ladders and cable trays stated in our catalog are produced from EN 6063 material*

*The material which are used with these products and shown as hot dip galvanized can be produced from EN 5052 aluminium material.*

Кабельные лестницы и кабельные подносы, заявленные в нашем каталоге произведены от EN 6063 материалов. Кабельные лотки и кабельные подносы, заявленные в нашем каталоге произведены от EN 5052 алюминия. Материал, которые используются с этими продуктами и показаны, поскольку горячее гальванированное падение может быть произведено от EN 5052 алюминия.



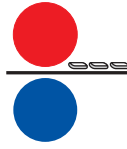

## ELEKTROSTATİK FIRIN BOYA

Sıcak daldırma galvaniz kaplama üzerine veya çeliğe elektrostatik boya ancak 250 °C'ye fırınlanarak, metalin üzerinde difüzyon delikleri açılarak kimyasal yapışma sağlanır. Aksi halde tabii şartlar, kimyasal şartlar neticesinde boya kabuk, kabuk dökülecektir.

Gersan kablo taşıyıcıları sisteminde amacına uygun özellikte estetik ve korozyona dayanıklılık için bütün RAL renkleri ile elektrostatik toz boya yöntemi ile boyama yapılır. Epoksi boyalar daha çok iç mekanlarda, polyester boyalar ise dış mekanlarda kullanım için tercih edilirler.

## Kiln-dried Electrostatic Paint

*Electrostatic paint can be kiln-dried on hot dip galvanised surfaces by heating up to 250 °C in order to have chemical diffusion between the paint and the surface. If not, by the effect of the nature or chemical reactions, the paint will get off the surface.*

*In Gersan's cable tray system, all RAL colours can be applied for a good looking and anti-corrosion protection by electrostatic painting. Epoxy paints are generally used indoors, polyester paints are generally used outdoors.*

## Электростатическая покраска методом напыления

Покрытие из электростатической краски высушивается в сушильных печах, на поверхностях с гальванизированным покрытием, нанесенным методом окунания в подогретый пропиточный состав, при температуре 250оС, для того, чтобы происходил химический диффузионный процесс между краской и поверхностью. Если эффект характерный для естественной или химической реакции не произойдет, краска выйдет на поверхность.

В АО «GERSAN A.Ş.» системы кабельных лотков при необходимости могут быть покрыты всеми видами цветовых оттенков RAL покрытия из электростатической краски, для придания эстетического внешнего вида и антикоррозионной защиты.

Покрытие из эпоксидной краски в основном применяется на закрытых поверхностях, а покрытие из полиэстеровой краски - на открытых поверхностях.

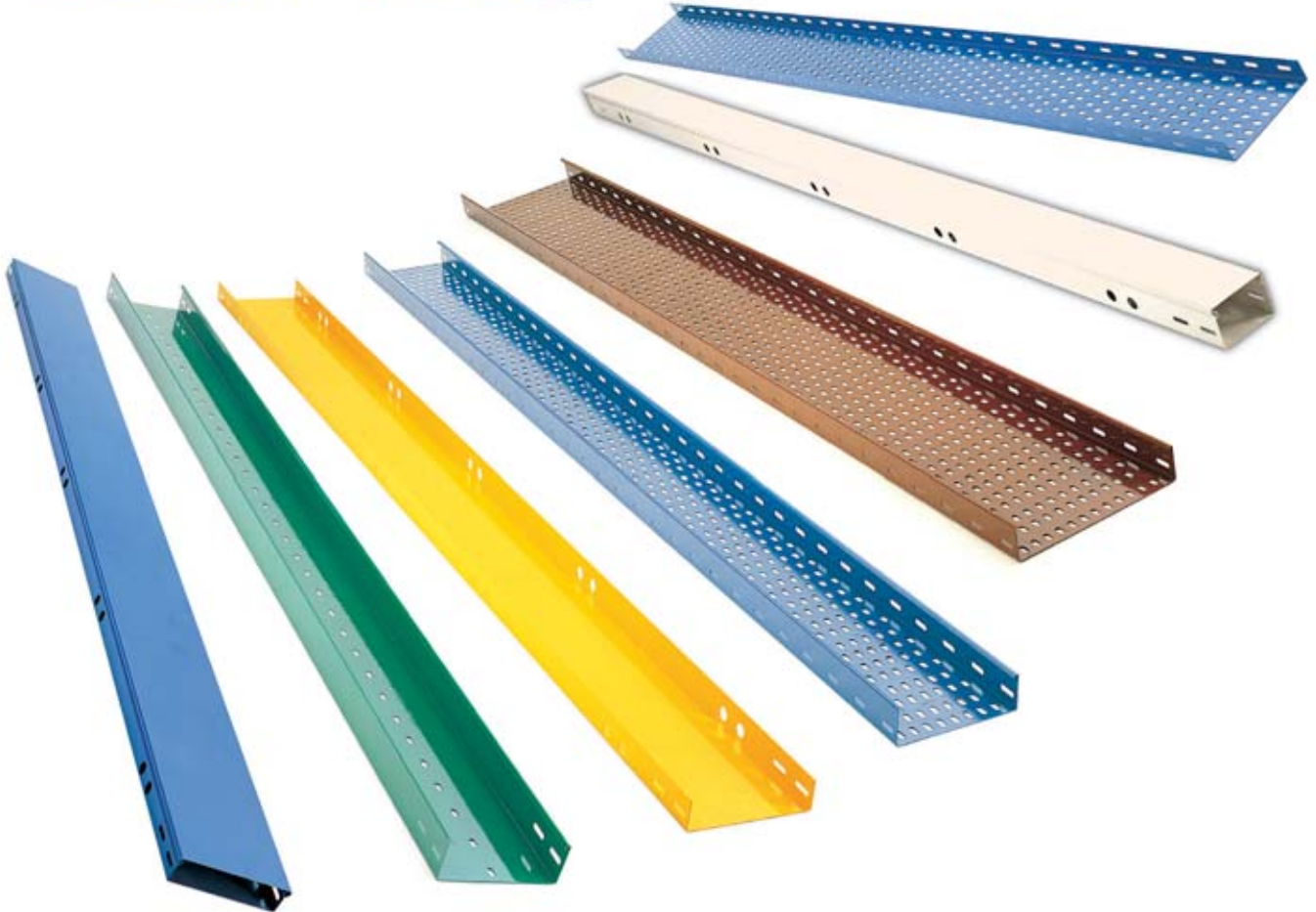



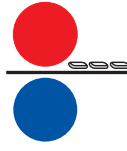

## TERMO-PLASTİK ÖZEL BOYA (RODINO 50®)

## Thermoplastic Coating (RODINO 50®)

Çelik veya sıcak daldırma galvaniz kaplanmış çelik üzerine TERMO-PLASTİK özel boya (RODINO 50®) uygulanır. Asite karşı mükemmel korozif koruma yapar. Tuz içeren, asit üretimi yapan, asitik ortam içeren, akü üreten, deniz suyunun içi gibi ortamlarda sıcak daldırma veya paslanmaz malzemelerin ömrü de kısadır. Bu ortamlarda çelik veya sıcak daldırma galvaniz kaplanmış çelik üzerine TERMO-PLASTİK özel boya (RODINO 50®) hem mukavemet hemde korozyon yönünden mükemmel koruma yapar. Asitli ortamın TERMO-PLASTİK özel boya (RODINO 50®) ya karşı etkisi çok azdır.

İletkenlerin kaçak akım, elektromekanik, frekans ve korozyondan doğacak etkilerini absorbe ederek sistemde oluşabilecek problemlerini ortadan kaldırır.

### Teknik Bilgiler

Uygulanması Gereken Boya Kalınlığı	150-250 mikron	
Görselliği	Düz/Gölgeli	
Darbe Mukavemeti	ISO 6272 Direkt 23°C Endirekt 0°C	2.7 Joule 18.0 Joule
Tuz testi	Çelik -Çizilmiş -Çizilmemiş	1000 saat testten sonra çizik etrafında 2-3 mm aşınma meydana gelmiştir. Aşınma yok
	Aluminyum -Çizilmiş -Çizilmemiş	Aşınma yok Aşınma yok
Kimyasal dayanımı	60 °C Asit 60 °C Alkali 60 °C Tuz 23 °C Solvent	İyi İyi İyi Zayıf
Hava Koşulları	-40 °C ile + 80 °C	Herhangi bir renk veya yapısal değişiklik yok.
Yanma karakteristiği	BS476 500 mikron boya	Kolay deforme olmuyor.

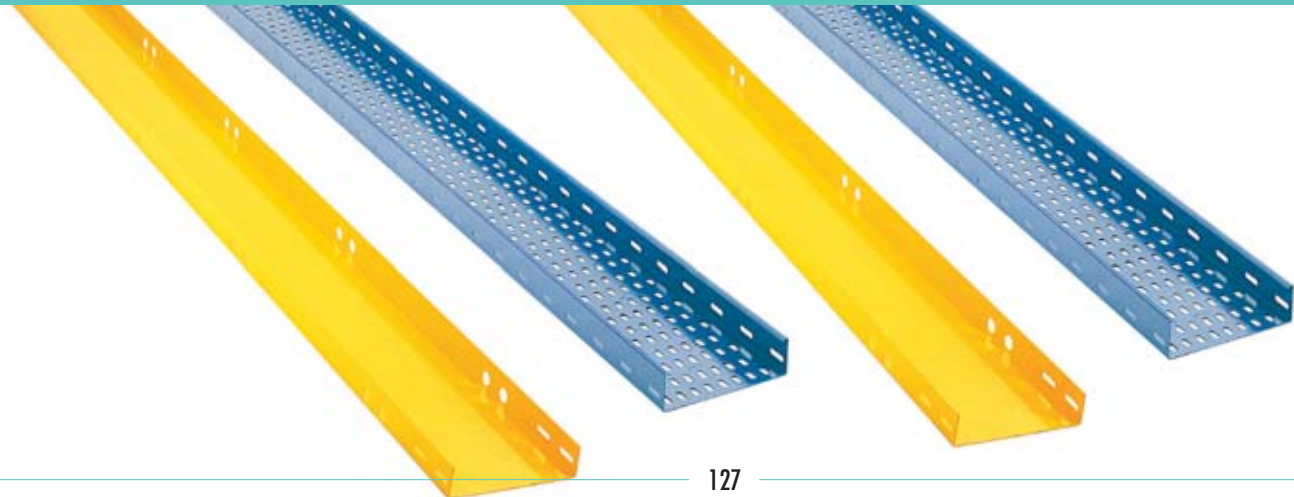

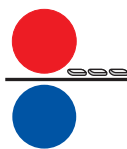

## Thermoplastic Coating (RODINO 50®)

Покрытие изоляцией Термо-Пласт (RODINO 50)

Thermoplastic Coating (RODINO 50®) is applied on both hot dip galvanized surfaces on bare steel products. Perfect protection is gained against corrosion from acid. Even hot dip galvanized or stainless steel products are not suitable for areas or plants which has a process with salt, manufactures acid, contains acidic products, manufactures batteries or for parts that are used under sea water. Thermoplastic Coating (RODINO 50®) has a perfect protection against corrosion and offers better strength.

Acidic surroundings has the minimum effect against special Thermoplastic Coating (RODINO 50®)

Prevents the problems that may be caused by leak current, electromechanical effects and corrosion of the conductors.

Покрываются цинком методом окунания или наносится краска из Термо-Пласта (RODINO 50).

Превосходное защита против кислоты. В средах соленой воды, производства кислоты, кислотной сферы, производства аккумуляторов, срок службы оцинкованной и нержавеющей стали достаточно короткий.

При таких случаях рекомендуем использовать горячеоцинкованную сталь покрытой термопластовой краской (RODINO 50)

### Technical Details Технические Данные

<b>Recommended Coating Thickness</b>		<b>150-250 microns</b>	
Рекомендуемая толщина покрытия .		150-250 микрон	
<b>Appearance</b>		<b>(Smooth/Glossy)</b>	
<b>Impact Strength</b> Механическая устойчивость.	<b>ISO 6272</b>		
	<b>Direct 23°C</b> Прямое 23 °C	<b>2.7 Joules</b>	
	<b>Indirect 0°C</b> Косвенное 0°C	<b>18.0 Joules</b>	
<b>Salt Spray</b> Под воздействием соленого раствора.	<b>Steel</b> Сталь	<b>Scribed</b> Поцарапанный	<b>Results after 1000 hours. Loss of adhesion less than 10 mm from scribe. under film corrosion 2-3 mm.</b> После 1000 часового испытания, вокруг царапины образовалось истирание глубиной 2-3 мм.
		<b>Unscribed</b> Не царапанный	<b>No loss of adhesion</b> Истираний нет
	<b>Aluminium</b> Алюминий	<b>Scribed</b> Поцарапанный	<b>No loss of adhesion</b> Истираний нет
		<b>Unscribed</b> Не царапанный	<b>No loss of adhesion</b> Истираний нет
<b>Chemical Resistance</b> Химическая устойчивость		<b>60 °C Acids</b> 60 °C Кислота	<b>Good</b> Хорошо
		<b>60 °C Alkali</b> 60 °C Щелочь	<b>Good</b> Хорошо
		<b>60 °C Salts - except peroxides</b> 60 °C Соль	<b>Good</b> Хорошо
		<b>23 °C Solvents</b> 23 °C Растворитель	<b>Poor</b> Слабо
<b>Weathering</b> Климатические условия	<b>-40 °C and + 80 °C</b> От -40 °C до +80 °C	<b>No significant change in colour or loss of gloss.</b> Не наблюдаются никаких цветовых и структурных изменений	
<b>Burning Characteristics</b> Противопожарные характеристики	<b>BS476</b> <b>500 Micron Coating</b> 500 микрон краски	<b>Not easily ignitable</b> Механически устойчив	

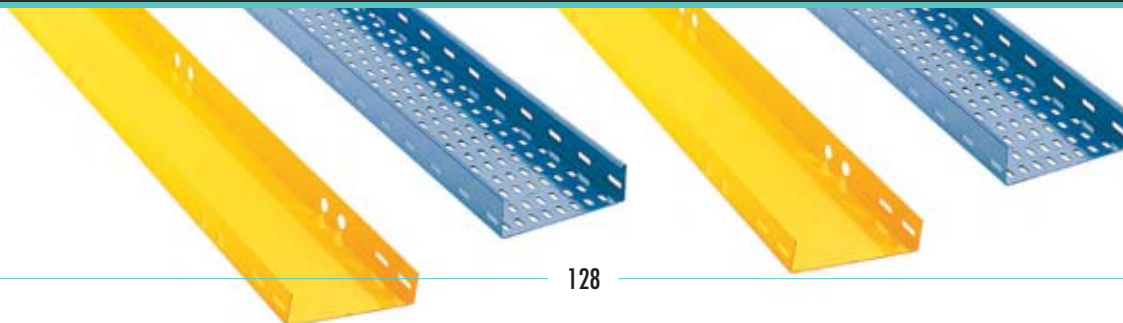

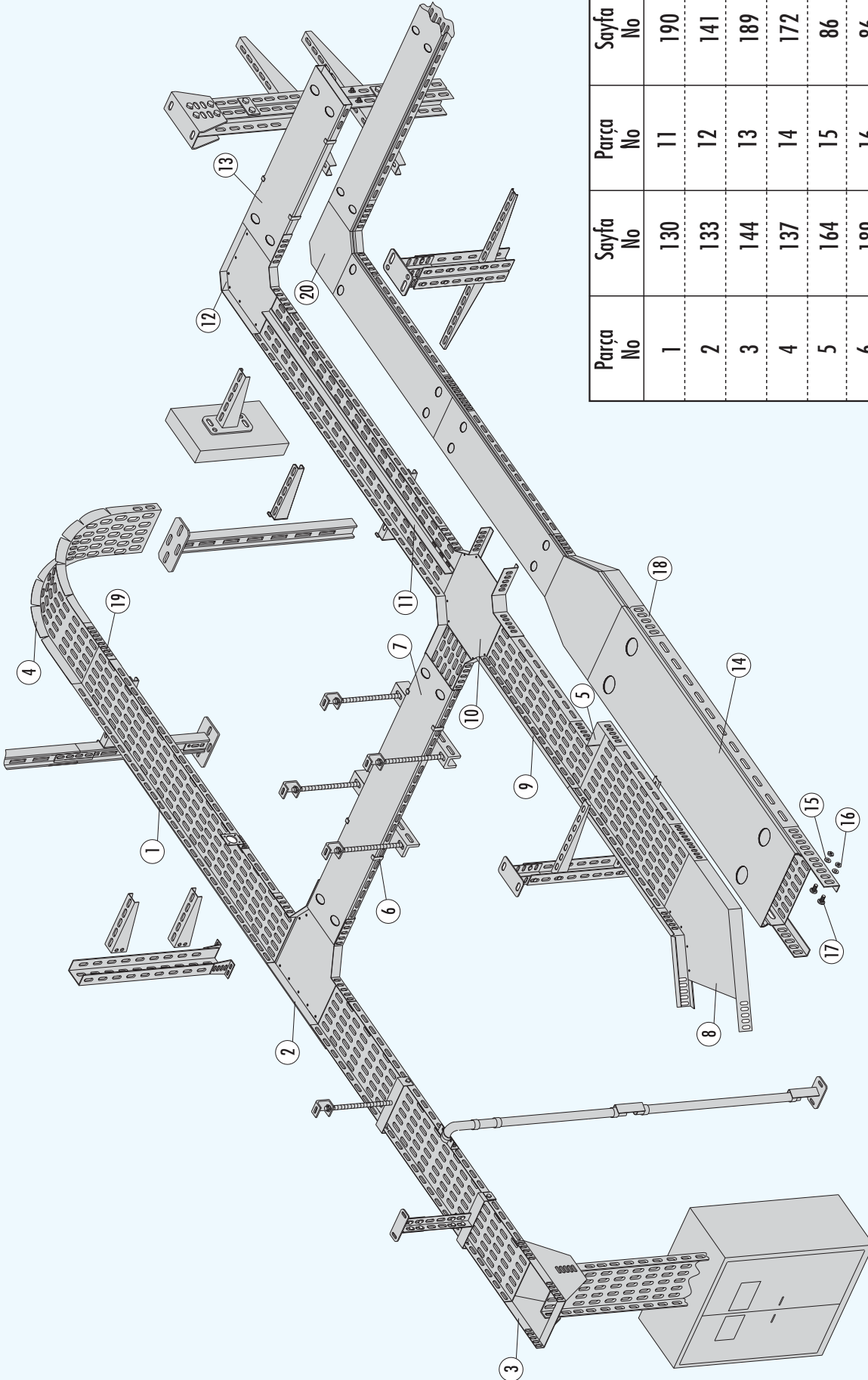
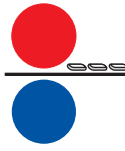

Parça No	Sayfa No	Parça No	Sayfa No
1	130	11	190
2	133	12	141
3	144	13	189
4	137	14	172
5	164	15	86
6	189	16	86
7	189	17	86
8	137	18	172
9	140	19	130
10	135	20	174



NORMAL TİP KABLO KANALLARI

Normal Type Cable Trays

Кабельные лотки нормального типа

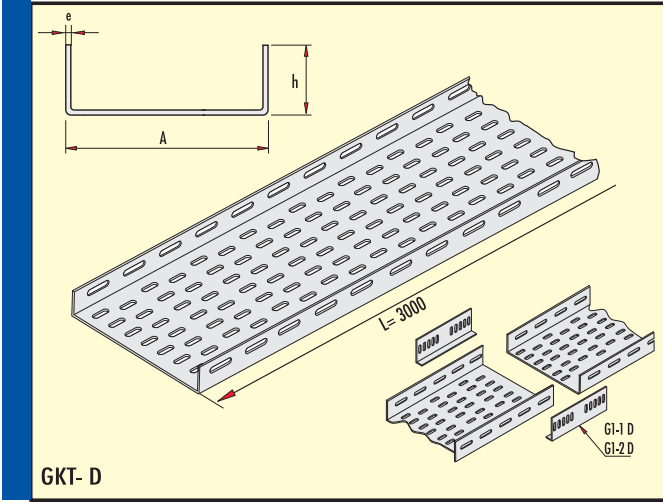

Normal Tip Kablo Kanalı (h=40 mm)

Normal Type Cable Tray (h=40 mm) Кабельные лотки нормального типа

Sipariş kodu Order code Код заявки	Ağırlık (Kg/mt.) Weight (Kg/mt) Вес (кг/м)	A mm	h mm	e mm	Price list прайс-лист М/у.е.	
					Pre-Galvanized Предв. Цинк-ия	Hot dip Galvanized гор.оцинк. HDZ
GKT-5 D	0,950	50	40	1	4,75	8,55
GKT-10-1 D	1,300	100	40	1	6,50	11,70
GKT-10-2 D	1,900	100	40	1,5	9,50	17,00
GKT-10-3 D	1,520	100	40	1,2	7,60	13,70
GKT-20 D	2,900	200	40	1,5	14,50	26,00
GKT-20-1 D	2,320	200	40	1,2	11,60	20,90
GKT-30-1 D	4,000	300	40	1,5	20,00	36,00
GKT-30-2 D	5,400	300	40	2	27,00	48,60
GKT-40 D	6,600	400	40	2	33,00	59,40
GKT-50 D	7,900	500	40	2	39,50	71,00
GKT-60 D	9,550	600	40	2	47,75	86,00

DELİKSİZ KAPAKLI TİP KABLO KANALLARI

Non Perforated Cable Trays With Cover

Кабельные лотки с крышкой.

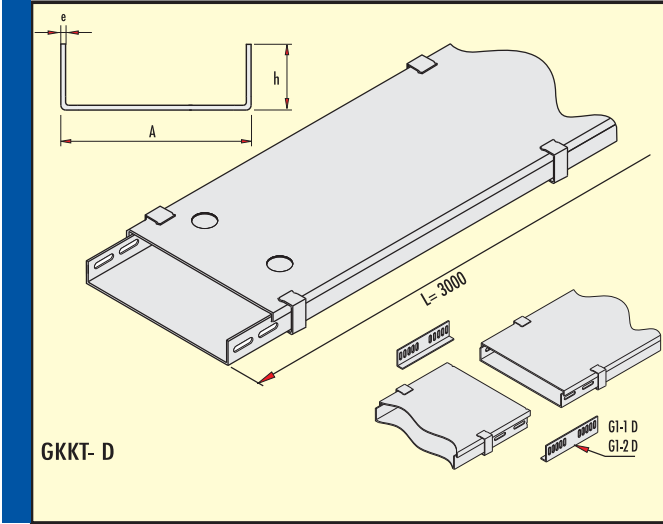

Deliksiz Kapaklı Tip Kablo Kanalı (h=40 mm)

Non Perforated Cable Tray With Cover (h=40 mm)

Кабельные лотки с крышкой.

Sipariş kodu Order code Код заявки	Ağırlık (Kg/mt.) Weight (Kg/mt) Вес (кг/м)	A mm	h mm	e mm	Price list прайс-лист М/у.е.	
					Pre-Galvanized Предв. Цинк-ия	Hot dip Galvanized гор.оцинк. HDZ
GKKT-5 D	1,700	50	40	1	6,80	13,60
GKKT-10-1 D	2,500	100	40	1	10,00	20,00
GKKT-10-2 D	3,300	100	40	1,5	13,20	26,40
GKKT-10-3 D	2,850	100	40	1,2	11,40	22,80
GKKT-20 D	5,300	200	40	1,5	21,20	42,40
GKKT-20-1 D	4,250	200	40	1,2	17,00	34,00
GKKT-30-1 D	7,550	300	40	1,5	30,20	60,40
GKKT-30-2 D	9,150	300	40	2	36,60	73,20
GKKT-40 D	13,500	400	40	2	54,00	108,00
GKKT-50 D	16,500	500	40	2	66,00	132,00
GKKT-60 D	19,650	600	40	2	78,60	157,20

EK PARÇASI Jointing Piece

Соединительные элементы

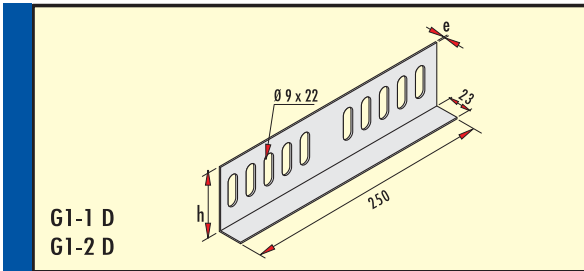

Ek Parçası (h=40 mm)  
Jointing Piece (h=40 mm)

Соединительные элементы

Sipariş kodu Order code Код заявки	Ağırlık (Kg/ad.) Weight (Kg/unit) Вес (кг/шт)	h mm	e mm	Price list прайс-лист шт/у.е.	
				Pre-Galvanized Предв. Цинк-ия	Hot dip Galvanized гор.оцинк. HDZ
G1-1 D	0,160	40	1.5	1.60	2.24
G1-2 D	0,200	40	2.00	2.00	2.80

Eşit aralıklarla destekleyiniz (Equal distance Support)

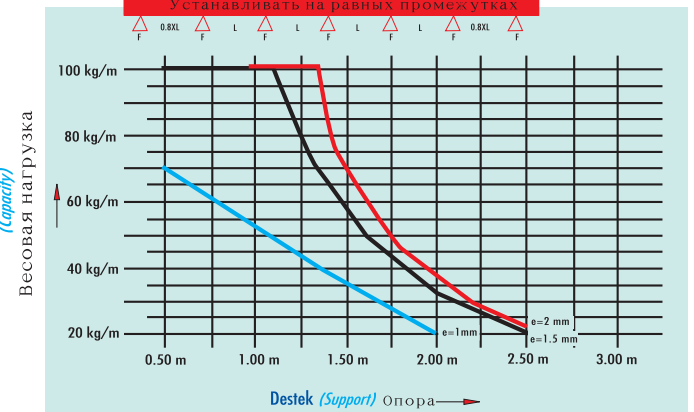

Kaplama : TS 914 EN ISO-1461 (BS-EN-ISO-1461) Sıcak Daldırma Galvaniz. Coating : TS 914 EN ISO-1461 (BS-EN-ISO-1461) Hot Dip Galvanized

Bu Ürünler İsteğe Bağlı Olarak Pregalvaniz ve CORTEN-A Saçdan İmal Edilebilir.

These products can be produced from Pregalvanized or CORTEN-A Steel according to the requirements.

Talep üzerine tüm ürünler RODINA 50® malzemesi ile kaplanarak (max) 400°C ısıya, asit, tuz ve kum etkilerine karşı mukavemet sağlar.

In case of required all type of materials can be coated with RODINA 50® which will give on extra resistant at effect of 400°C heat, acid, salt and sand for the material.

90° DÖNÜŞ ELEMANLARI

90° Flat Bends

Угловые элементы 90°

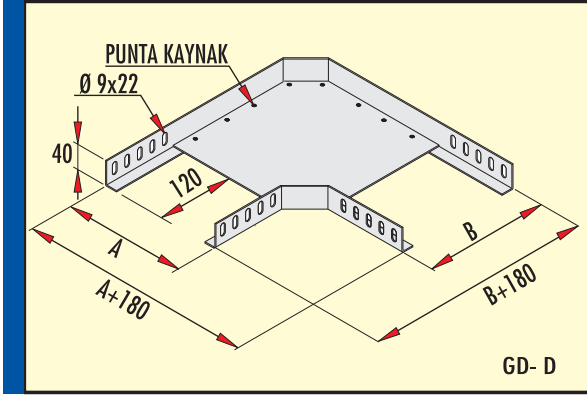

90° Dönüş Elemanı (h=40 mm)

90° Flat Bend (h=40 mm)

угловые элементы 90°

Sipariş kodu Order code Код заявки	Ağırlık (Kg/ad.) Weight (Kg/unit) Вес (кг / шт)	A mm	B mm	e mm	Price list прайс-лист шт./у.е.	
					Pre-Galvanized Предв. Цинк-ия	Hot dip Galvanized гор.оцинк. HDZ
GD-5 D	0,445	54	54	1	3,60	5,30
GD-10 D	0,873	104	104	1,5	7,00	10,50
GD-20 D	1,435	205	205	1,5	11,50	17,20
GD-30 D	2,930	305	305	2	23,40	35,20
GD-40 D	4,280	405	405	2	34,20	51,40
GD-50 D	5,880	506	506	2	47,00	70,60
GD-60 D	7,770	606	606	2	62,20	93,20

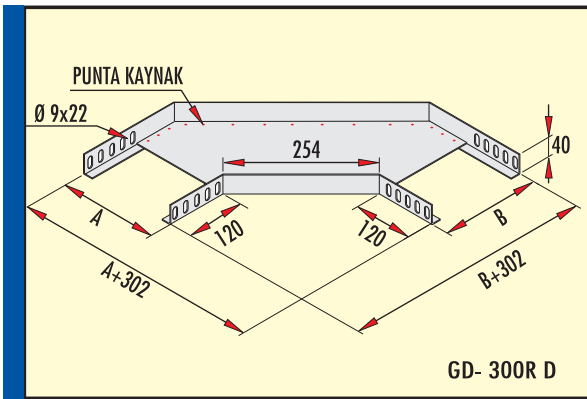

90° Dönüş Elemanı 300 Radius (h=40 mm)

90° Flat Bend Radius 300 (h=40 mm)

Sipariş kodu Order code Код заявки	Ağırlık (Kg/ad.) Weight (Kg/unit) Вес (кг / шт)	A mm	B mm	e mm	Price list прайс-лист шт./у.е.	
					Pre-Galvanized Предв. Цинк-ия	Hot dip Galvanized гор.оцинк. HDZ
GD-5 300R D	0,700	54	54	1	5,60	8,40
GD-10 300R D	1,840	104	104	1,5	14,70	22,10
GD-20 300R D	2,800	205	205	1,5	22,40	33,60
GD-30 300R D	5,250	305	305	2	42,00	63,00
GD-40 300R D	7,020	405	405	2	56,20	84,20
GD-50 300R D	9,040	506	506	2	72,30	108,50
GD-60 300R D	11,040	606	606	2	88,30	132,50

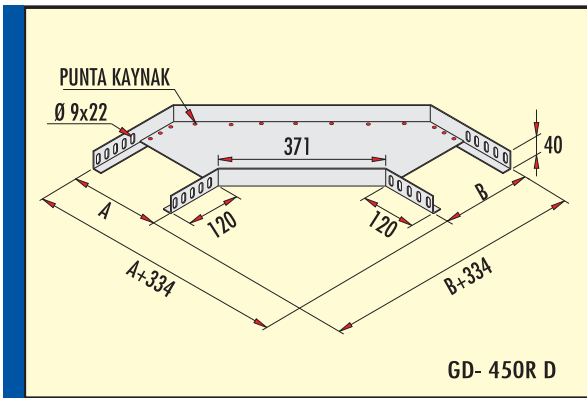

90° Dönüş Elemanı 450 Radius (h=40 mm)

90° Flat Bend Radius 450 (h=40 mm)

Sipariş kodu Order code Код заявки	Ağırlık (Kg/ad.) Weight (Kg/unit) Вес (кг / шт)	A mm	B mm	e mm	Price list прайс-лист шт./у.е.	
					Pre-Galvanized Предв. Цинк-ия	Hot dip Galvanized гор.оцинк. HDZ
GD-5 450R D	0,900	54	54	1	7,20	10,80
GD-10 450R D	2,480	104	104	1,5	19,80	29,80
GD-20 450R D	3,710	205	205	1,5	29,70	44,50
GD-30 450R D	6,830	305	305	2	54,60	82,00
GD-40 450R D	8,890	405	405	2	71,10	106,70
GD-50 450R D	11,360	506	506	2	90,90	136,30
GD-60 450R D	14,000	606	606	2	112,00	168,00

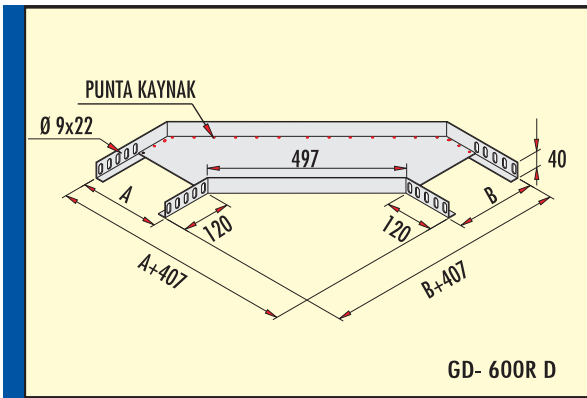

90° Dönüş Elemanı 600 Radius (h=40 mm)

90° Flat Bend Radius 600 (h=40 mm)

Sipariş kodu Order code Код заявки	Ağırlık (Kg/ad.) Weight (Kg/unit) Вес (кг / шт)	A mm	B mm	e mm	Price list прайс-лист шт./у.е.	
					Pre-Galvanized Предв. Цинк-ия	Hot dip Galvanized гор.оцинк. HDZ
GD-5 600R D	1,200	54	54	1	9,60	14,40
GD-10 600R D	3,110	104	104	1,5	24,90	37,30
GD-20 600R D	4,620	205	205	1,5	37,00	55,40
GD-30 600R D	8,420	305	305	2	67,40	101,00
GD-40 600R D	10,930	405	405	2	87,40	131,20
GD-50 600R D	13,690	506	506	2	109,50	164,30
GD-60 600R D	16,690	606	606	2	133,50	200,30

Kaplama : TS 914 EN ISO-1461 (BS-EN-ISO-1461) Sıcak Daldırma Galvaniz.  
Bu ürünler isteğe bağlı olarak Pregalvaniz ve CORTEN-A Saçdan İmal Edilebilir.

Coating : TS 914 EN ISO-1461 (BS-EN-ISO-1461) Hot Dip Galvanized  
These products can be produced from Pregalvanized or CORTEN-A Steel according to the requirements.

Talep üzerine tüm ürünler RODINA 50® malzemesi ile kaplanarak (max) 400°C ısıya, asit, tuz ve kum etkilerine karşı mukavemet sağlar.

In case of required all type of materials can be coated with RODINA 50® which will give on extra resistant at effect of 400°C heat, acid, salt and sand for the material.

90° DÖNÜŞ KAPAKLARI

90° Flat Bend Covers

Крышка для угла 90°

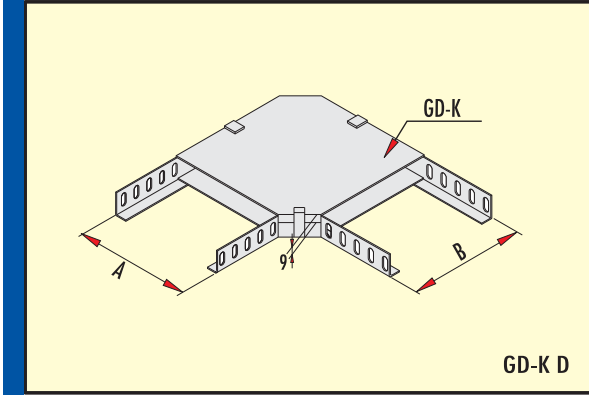

**90° Dönüş Kapağı**  
**90° Flat Bend Cover**  
Крышка для угла 90°

Sipariş kodu Order code Код заявки	Ağırlık (Kg/ad.) Weight (Kg/unit) Вес (кг / шт)	A mm	B mm	e mm	Price list прайс-лист шт /у.е.	
					Pre-Galvanized Предв. Цинк-ия	Hot dip Galvanized гор.оцинк. HDZ
GD-5K D	0,090	54	54	1	0,72	1,10
GD-10K D	0,200	104	104	1	1,60	2,40
GD-20K D	0,550	205	205	1	4,40	6,60
GD-30K D	1,020	305	305	1	8,16	12,24
GD-40K D	2,700	405	405	1.5	21,60	32,40
GD-50K D	4,050	506	506	1.5	32,40	48,60
GD-60K D	5,600	606	606	1.5	44,80	67,20

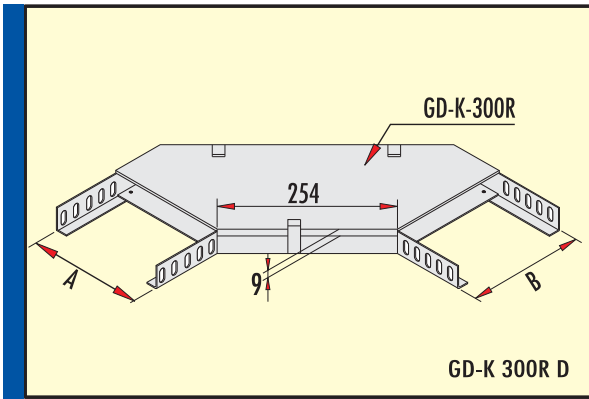

**90° Dönüş Kapağı 300 Radüs**  
**90° Flat Bend Cover Radius 300**  
Крышка для угла 90° (Радиус 300)

Sipariş kodu Order code Код заявки	Ağırlık (Kg/ad.) Weight (Kg/unit) Вес (кг / шт)	A mm	B mm	e mm	Price list прайс-лист шт /у.е.	
					Pre-Galvanized Предв. Цинк-ия	Hot dip Galvanized гор.оцинк. HDZ
GD-5K 300R D	0,250	54	54	1	2,00	3,00
GD-10K 300R D	0,350	104	104	1	2,80	4,20
GD-20K 300R D	0,750	205	205	1	6,00	9,00
GD-30K 300R D	1,250	305	305	1	10,00	15,00
GD-40K 300R D	3,100	405	405	1.5	24,80	37,00
GD-50K 300R D	4,300	506	506	1.5	34,40	51,00
GD-60K 300R D	5,750	606	606	1.5	46,00	69,00

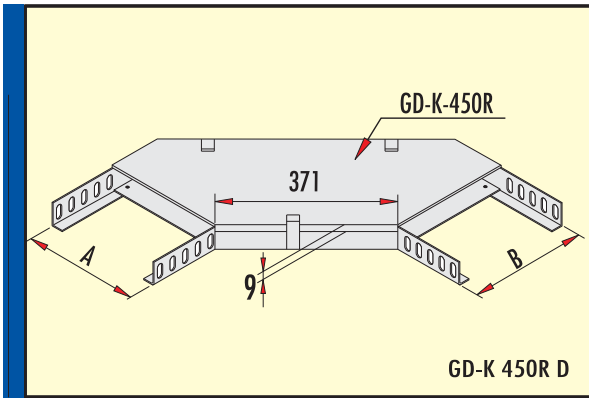

**90° Dönüş Kapağı 450 Radüs**  
**90° Flat Bend Cover Radius 450**  
Крышка для угла 90° (Радиус 450)

Sipariş kodu Order code Код заявки	Ağırlık (Kg/ad.) Weight (Kg/unit) Вес (кг / шт)	A mm	B mm	e mm	Price list прайс-лист шт /у.е.	
					Pre-Galvanized Предв. Цинк-ия	Hot dip Galvanized гор.оцинк. HDZ
GD-5K 450R D	0,350	54	54	1	2,80	4,20
GD-10K 450R D	0,450	104	104	1	3,60	5,40
GD-20K 450R D	0,950	205	205	1	7,60	11,40
GD-30K 450R D	1,550	305	305	1	12,40	18,60
GD-40K 450R D	3,700	405	405	1.5	29,60	44,40
GD-50K 450R D	5,050	506	506	1.5	40,00	60,80
GD-60K 450R D	6,650	606	606	1.5	53,20	79,80

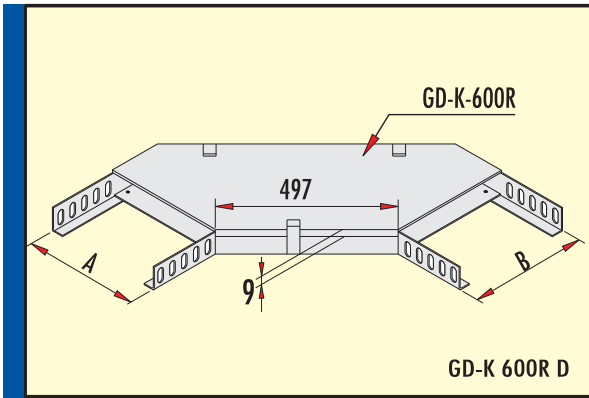

**90° Dönüş Kapağı 600 Radüs**  
**90° Flat Bend Cover Radius 600**  
Крышка для угла 90° (Радиус 600)

Sipariş kodu Order code Код заявки	Ağırlık (Kg/ad.) Weight (Kg/unit) Вес (кг / шт)	A mm	B mm	e mm	Price list прайс-лист шт /у.е.	
					Pre-Galvanized Предв. Цинк-ия	Hot dip Galvanized гор.оцинк. HDZ
GD-5K 600R D	0,450	54	54	1	3,60	5,40
GD-10K 600R D	0,550	104	104	1	4,40	6,60
GD-20K 600R D	1,150	205	205	1	9,20	13,80
GD-30K 600R D	1,850	305	305	1	14,80	22,00
GD-40K 600R D	4,200	405	405	1.5	33,60	50,00
GD-50K 600R D	5,800	506	506	1.5	46,40	70,00
GD-60K 600R D	7,600	606	606	1.5	60,80	91,20

Kaplama : TS 914 EN ISO-1461 (BS-EN-ISO-1461) Sıcak Daldırma Galvaniz. Coating : TS 914 EN ISO-1461 (BS-EN-ISO-1461) Hot Dip Galvanized

Bu Ürünler İsteğe Bağlı Olarak Pregalvaniz ve CORTEN-A Saçdan İmal Edilebilir.

These products can be produced from Pregalvanized or CORTEN-A Steel according to the requirements.

Talep üzerine tüm ürünler RODINA 50® malzemesi ile kaplanarak (max) 400°C ısıya, asit, tuz ve kum etkilerine karşı mukavemet sağlar.

In case of required all type of materials can be coated with RODINA 50® which will give on extra resistant at effect of 400°C heat, acid, salt and sand for the material.



T BAĞLANTI ELEMANLARI

Tees "T"

«T» образные соединительные элементы

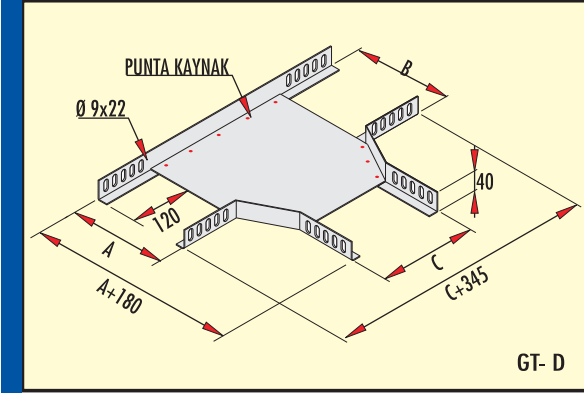

T Bağlantı Elemanı (h=40 mm)

Tees "T" (h=40 mm)

«T» образные соединительные элементы

Sipariş kodu Order code Код заявки	Ağırlık (Kg/ad.) Weight (Kg/unit) Вес (кг / шт)	A mm	B mm	C mm	e mm	Price list прайс-лист шт / у.е.	
						Pre-Galvanized Предв. Цинк-ия	Hot dip Galvanized гор.оцинк. HDZ
GT-5 D	0,550	54	54	54	1	4,40	6,60
GT-10 D	1,050	104	104	104	1.5	8,40	12,60
GT-20 D	1,600	205	205	205	1.5	12,80	19,20
GT-30 D	3,300	305	305	305	2	26,40	39,60
GT-40 D	4,650	405	405	405	2	37,20	55,80
GT-50 D	6,450	506	506	506	2	51,60	77,40
GT-60 D	8,500	606	606	606	2	68,00	102,00

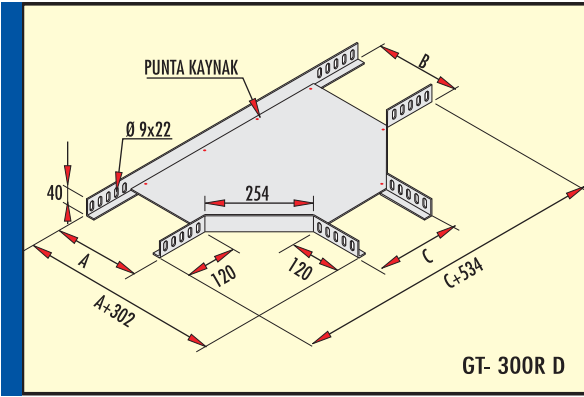

T Bağlantı Elemanı 300 Radius (h=40 mm)

Tees "T" Radius 300 (h=40 mm)

«T» образные соединительные элементы (Радиус 300)

Sipariş kodu Order code Код заявки	Ağırlık (Kg/ad.) Weight (Kg/unit) Вес (кг / шт)	A mm	B mm	C mm	e mm	Price list прайс-лист шт / у.е.	
						Pre-Galvanized Предв. Цинк-ия	Hot dip Galvanized гор.оцинк. HDZ
GT-5 300R D	1,350	54	54	54	1	10,80	16,00
GT-10 300R D	2,350	104	104	104	1.5	18,80	28,20
GT-20 300R D	3,600	205	205	205	1.5	29,00	43,00
GT-30 300R D	6,600	305	305	305	2	52,80	79,00
GT-40 300R D	9,000	405	405	405	2	72,00	108,00
GT-50 300R D	11,300	506	506	506	2	90,00	132,00
GT-60 300R D	14,150	606	606	606	2	112,00	170,00

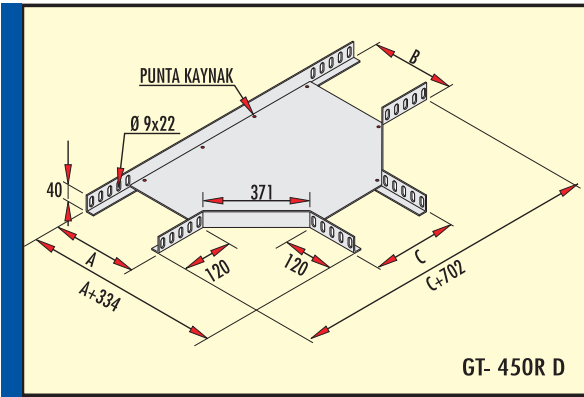

T Bağlantı Elemanı 450 Radius (h=40 mm)

Tees "T" Radius 450 (h=40 mm)

«T» образные соединительные элементы (Радиус 450)

Sipariş kodu Order code Код заявки	Ağırlık (Kg/ad.) Weight (Kg/unit) Вес (кг / шт)	A mm	B mm	C mm	e mm	Price list прайс-лист шт / у.е.	
						Pre-Galvanized Предв. Цинк-ия	Hot dip Galvanized гор.оцинк. HDZ
GT-5 450R D	2,200	54	54	54	1	17,60	26,00
GT-10 450R D	3,220	104	104	104	1.5	26,00	38,00
GT-20 450R D	5,350	205	205	205	1.5	43,00	64,00
GT-30 450R D	9,600	305	305	305	2	77,00	115,00
GT-40 450R D	12,450	405	405	405	2	100,00	149,00
GT-50 450R D	15,500	506	506	506	2	124,00	186,00
GT-60 450R D	17,750	606	606	606	2	141,00	212,00

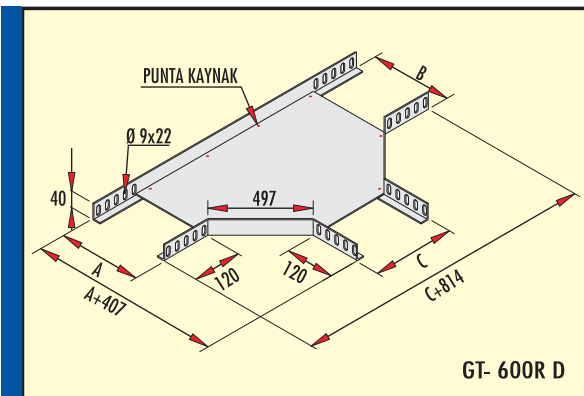

T Bağlantı Elemanı 600 Radius (h=40 mm)

Tees "T" Radius 600 (h=40 mm)

«T» образные соединительные элементы (Радиус 600)

Sipariş kodu Order code Код заявки	Ağırlık (Kg/ad.) Weight (Kg/unit) Вес (кг / шт)	A mm	B mm	C mm	e mm	Price list прайс-лист шт / у.е.	
						Pre-Galvanized Предв. Цинк-ия	Hot dip Galvanized гор.оцинк. HDZ
GT-5 600R D	3,100	54	54	54	1	25,00	37,00
GT-10 600R D	4,720	104	104	104	1.5	38,00	56,00
GT-20 600R D	7,200	205	205	205	1.5	58,00	86,00
GT-30 600R D	12,500	305	305	305	2	100,00	150,00
GT-40 600R D	15,850	405	405	405	2	126,00	180,00
GT-50 600R D	18,000	506	506	506	2	144,00	216,00
GT-60 600R D	21,700	606	606	606	2	173,00	260,00

Kaplama : TS 914 EN ISO-1461 (BS-EN-ISO-1461) Sıcak Daldırma Galvaniz. Coating : TS 914 EN ISO-1461 (BS-EN-ISO-1461) Hot Dip Galvanized

Bu Ürünler İsteğe Bağlı Olarak Pregalvaniz ve CORTEN-A Saçdan İmal Edilebilir.

These products can be produced from Pregalvanized or CORTEN-A Steel according to the requirements.

Talep üzerine tüm ürünler RODINA 50® malzemesi ile kaplanarak (max) 400°C ısıya, asit, tuz ve kum etkilerine karşı mukavemet sağlar.

In case of required all type of materials can be coated with RODINA 50® which will give on extra resistant at effect of 400°C heat, acid, salt and sand for the material.

T BAĞLANTI KAPAKLARI

Tees "T" Covers

«Т» образные соединительные элементы

T Bağlantı Kapağı

Tees "T" Cover

«Т» образные соединительные элементы

Sipariş kodu Order code Код заявки	Ağırlık (Kg/ad.) Weight (Kg/unit) Вес (кг/шт)	A mm	B mm	C mm	e mm	Price list прайс-лист шт./у.е.	
						Pre-Galvanized Предв. Цинк-ия	Hot dip Galvanized гор.оцинк. HDZ
GT-5K D	0,150	54	54	54	1	1,20	2,00
GT-10K D	0,250	104	104	104	1	2,00	3,00
GT-20K D	0,600	205	205	205	1	4,80	7,20
GT-30K D	1,100	305	305	305	1	8,80	13,20
GT-40K D	2,750	405	405	405	1.5	22,00	33,00
GT-50K D	4,000	506	506	506	1.5	32,00	48,00
GT-60K D	5,500	606	606	606	1.5	44,00	66,00

T Bağlantı Kapağı 300 Radius

Tees "T" Cover Radius 300

«Т» образные соединительные элементы (Радиус 300)

Sipariş kodu Order code Код заявки	Ağırlık (Kg/ad.) Weight (Kg/unit) Вес (кг/шт)	A mm	B mm	C mm	e mm	Price list прайс-лист шт./у.е.	
						Pre-Galvanized Предв. Цинк-ия	Hot dip Galvanized гор.оцинк. HDZ
GT-5K 300R D	0,650	54	54	54	1	5,50	8,00
GT-10K 300R D	1,000	104	104	104	1	8,00	12,00
GT-20K 300R D	1,800	205	205	205	1	14,50	22,00
GT-30K 300R D	2,800	305	305	305	1	22,50	33,00
GT-40K 300R D	6,150	405	405	405	1.5	49,00	74,00
GT-50K 300R D	8,100	506	506	506	1.5	65,00	97,00
GT-60K 300R D	10,450	606	606	606	1.5	84,00	125,00

T Bağlantı Kapağı 450 Radius

Tees "T" Cover Radius 450

«Т» образные соединительные элементы (Радиус 450)

Sipariş kodu Order code Код заявки	Ağırlık (Kg/ad.) Weight (Kg/unit) Вес (кг/шт)	A mm	B mm	C mm	e mm	Price list прайс-лист шт./у.е.	
						Pre-Galvanized Предв. Цинк-ия	Hot dip Galvanized гор.оцинк. HDZ
GT-5K 450R D	1,100	54	54	54	1	8,80	13,00
GT-10K 450R D	1,500	104	104	104	1	12,00	18,00
GT-20K 450R D	2,600	205	205	205	1	21,00	31,00
GT-30K 450R D	3,850	305	305	305	1	31,00	46,00
GT-40K 450R D	7,900	405	405	405	1.5	63,00	95,00
GT-50K 450R D	10,400	506	506	506	1.5	83,00	125,00
GT-60K 450R D	13,150	606	606	606	1.5	105,00	158,00

T Bağlantı Kapağı 600 Radius

Tees "T" Cover Radius 600

«Т» образные соединительные элементы (Радиус 600)

Sipariş kodu Order code Код заявки	Ağırlık (Kg/ad.) Weight (Kg/unit) Вес (кг/шт)	A mm	B mm	C mm	e mm	Price list прайс-лист шт./у.е.	
						Pre-Galvanized Предв. Цинк-ия	Hot dip Galvanized гор.оцинк. HDZ
GT-5K 600R D	1,300	54	54	54	1	10,50	16,00
GT-10K 600R D	1,700	104	104	104	1	14,00	20,00
GT-20K 600R D	3,100	205	205	205	1	25,00	37,00
GT-30K 600R D	5,100	305	305	305	1	41,00	61,00
GT-40K 600R D	10,250	405	405	405	1.5	82,00	123,00
GT-50K 600R D	13,000	506	506	506	1.5	104,00	156,00
GT-60K 600R D	16,150	606	606	606	1.5	129,00	194,00

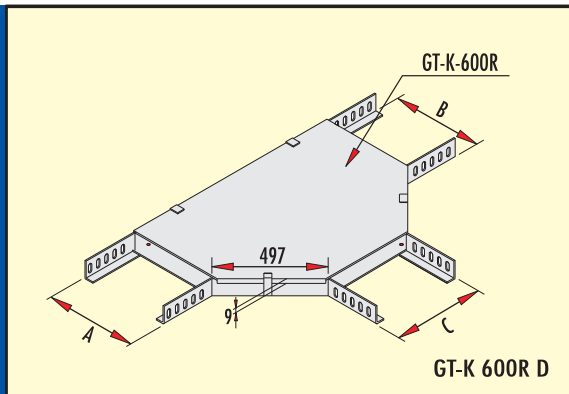
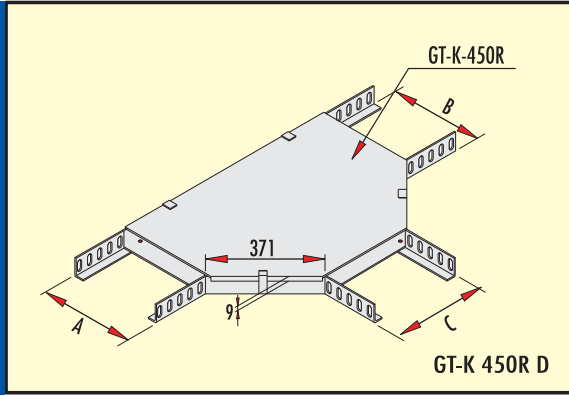
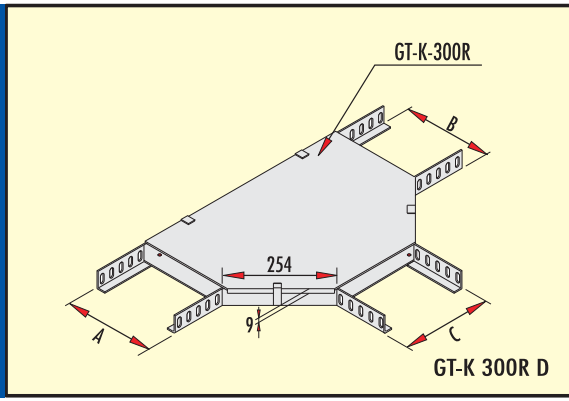
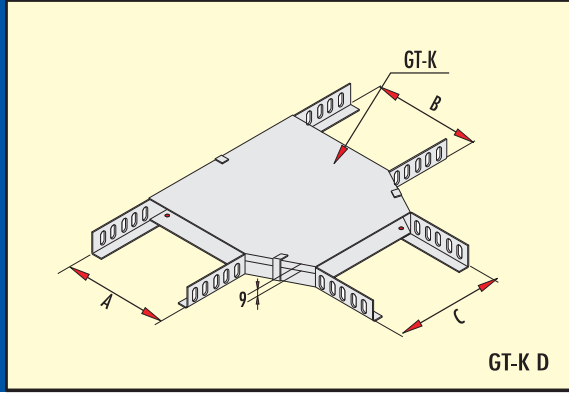

Kaplama : TS 914 EN ISO-1461 (BS-EN-ISO-1461) Sıcak Daldırma Galvaniz. Coating : TS 914 EN ISO-1461 (BS-EN-ISO-1461) Hot Dip Galvanized

Bu Ürünler İsteğe Bağlı Olarak Pregalvaniz ve CORTEN-A Saçdan İmal Edilebilir.

These products can be produced from Pregalvanized or CORTEN-A Steel according to the requirements.

Talep üzerine tüm ürünler RODINA 50® malzemesi ile kaplanarak (max) 400°C ısıya, asit, tuz ve kum etkilerine karşı mukavemet sağlar.

In case of required all type of materials can be coated with RODINA 50® which will give on extra resistant at effect of 400°C heat, acid, salt and sand for the material.

## DÖRTLÜ BAĞLANTI ELEMANLARI

крестообразные соединительные элементы

## Crossing Elements

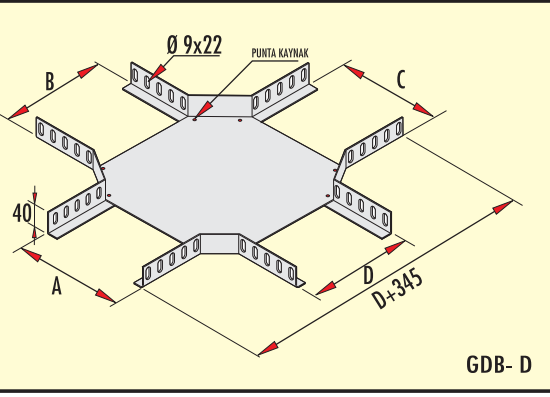

### Dörtlü Bağlantı Elemanı (h=40 mm)

#### Crossing Element (h=40 mm)

крестообразные соединительные элементы

Sipariş kodu Order code Код заявки	Ağırlık (Kg/ad.) Weight (Kg/unit) Вес (кг/шт)	A mm	B mm	C mm	D mm	e mm	Price list прайс-лист шт/у.е.	
							Pre-Galvanized Предв. Цинк-ия	Hot dip Galvanized гор.оцинк. HDZ
GDB-5 D	0,700	54	54	54	54	1	5,60	8,40
GDB-10 D	1,350	104	104	104	104	1.5	10,80	16,00
GDB-20 D	1,950	205	205	205	205	1.5	15,60	23,00
GDB-30 D	3,850	305	305	305	305	2	31,00	46,00
GDB-40 D	5,300	405	405	405	405	2	42,00	63,60
GDB-50 D	7,100	506	506	506	506	2	57,00	85,00
GDB-60 D	9,300	606	606	606	606	2	75,00	111,00

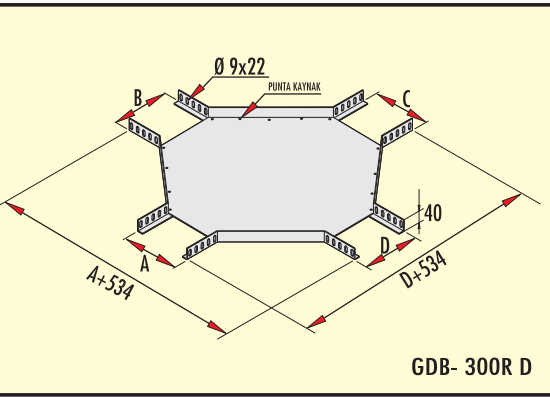

### Dörtlü Bağlantı Elemanı 300 RADIUS (h=40 mm)

#### Crossing Element Radius 300 (h=40 mm)

крестообразные соединительные элементы (Радиус 300)

Sipariş kodu Order code Код заявки	Ağırlık (Kg/ad.) Weight (Kg/unit) Вес (кг/шт)	A mm	B mm	C mm	D mm	e mm	Price list прайс-лист шт/у.е.	
							Pre-Galvanized Предв. Цинк-ия	Hot dip Galvanized гор.оцинк. HDZ
GDB-5 300R D	1,600	54	54	54	54	1	12,80	19,20
GDB-10 300R D	2,950	104	104	104	104	1.5	23,60	35,40
GDB-20 300R D	4,400	205	205	205	205	1.5	35,20	52,80
GDB-30 300R D	7,850	305	305	305	305	2	62,80	94,20
GDB-40 300R D	10,300	405	405	405	405	2	82,40	123,60
GDB-50 300R D	13,050	506	506	506	506	2	104,40	156,60
GDB-60 300R D	16,250	606	606	606	606	2	130,00	195,00

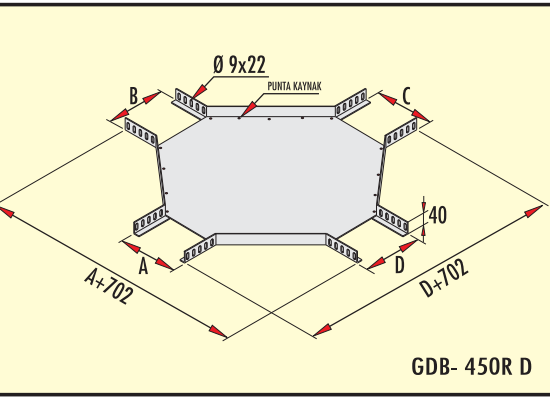

### Dörtlü Bağlantı Elemanı 450 RADIUS (h=40 mm)

#### Crossing Element Radius 450 (h=40 mm)

крестообразные соединительные элементы (Радиус 450)

Sipariş kodu Order code Код заявки	Ağırlık (Kg/ad.) Weight (Kg/unit) Вес (кг/шт)	A mm	B mm	C mm	D mm	e mm	Price list прайс-лист шт/у.е.	
							Pre-Galvanized Предв. Цинк-ия	Hot dip Galvanized гор.оцинк. HDZ
GDB-5 450R D	2.400	54	54	54	54	1	19,20	28,80
GDB-10 450R D	4.500	104	104	104	104	1.5	36,00	54,00
GDB-20 450R D	6.700	205	205	205	205	1.5	53,60	80,00
GDB-30 450R D	11.600	305	305	305	305	2	92,80	139,00
GDB-40 450R D	14.650	405	405	405	405	2	117,00	175,00
GDB-50 450R D	17.900	506	506	506	506	2	143,00	214,00
GDB-60 450R D	21.650	606	606	606	606	2	173,00	259,00

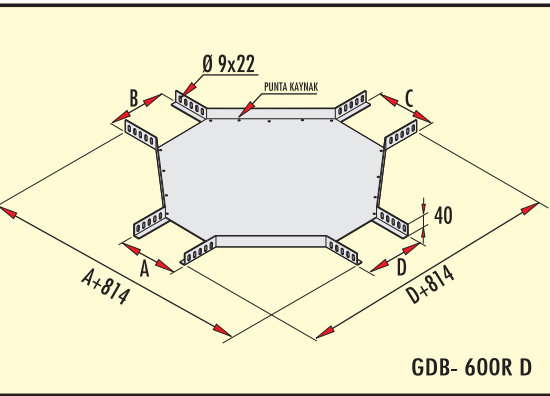

### Dörtlü Bağlantı Elemanı 600 RADIUS (h=40 mm)

#### Crossing Element Radius 600 (h=40 mm)

крестообразные соединительные элементы (Радиус 600)

Sipariş kodu Order code Код заявки	Ağırlık (Kg/ad.) Weight (Kg/unit) Вес (кг/шт)	A mm	B mm	C mm	D mm	e mm	Price list прайс-лист шт/у.е.	
							Pre-Galvanized Предв. Цинк-ия	Hot dip Galvanized гор.оцинк. HDZ
GDB-5 600R D	3.600	54	54	54	54	1	29,00	43,00
GDB-10 600R D	5.850	104	104	104	104	1.5	47,00	70,00
GDB-20 600R D	8.550	205	205	205	205	1.5	68,00	102,00
GDB-30 600R D	14.450	305	305	305	305	2	115,00	173,00
GDB-40 600R D	17.900	405	405	405	405	2	143,00	214,00
GDB-50 600R D	21.800	506	506	506	506	2	174,00	261,00
GDB-60 600R D	26.000	606	606	606	606	2	208,00	312,00

Kaplama : TS 914 EN ISO-1461 (BS-EN-ISO-1461) Sıcak Daldırma Galvaniz.  
Bu Ürünler İsteğe Bağlı Olarak Pregalvaniz ve CORTEN-A Saçdan İmal Edilebilir.

Coating : TS 914 EN ISO-1461 (BS-EN-ISO-1461) Hot Dip Galvanized  
These products can be produced from Pregalvanized or CORTEN-A Steel according to the requirements.

Talep üzerine tüm ürünler RODINA 50® malzemesi ile kaplanarak (max) 400°C ısıya, asit, tuz ve kum etkilerine karşı mukavemet sağlar.

In case of required all type of materials can be coated with RODINA 50® which will give on extra resistant at effect of 400°C heat, acid, salt and sand for the material.



DÖRTLÜ BAĞLANTI KAPAĞI

Crossings Covers

Крестообразные соединительные элементы

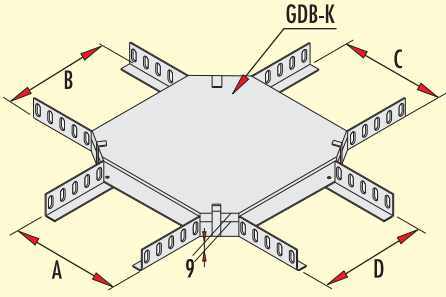

GDB-K D

Dörtlü Bağlantı Kapağı (h=40 mm) Crossings Element (h=40 mm)

Крестообразные соединительные элементы

Sipariş kodu Order code Код заявки	Ağırlık (Kg/ad.) Weight (Kg/unit) Вес (кг/шт)	A mm	B mm	C mm	D mm	e mm	Price list прайс-лист шт/у.е.	
							Pre-Galvanized Предв. Цинк-ия	Hot dip Galvanized гор.оцинк. HDZ
GDB-5K D	0,200	54	54	54	54	1	1,60	2,40
GDB-10K D	0,300	104	104	104	104	1	2,40	3,60
GDB-20K D	0,700	205	205	205	205	1	5,60	8,40
GDB-30K D	1,250	305	305	305	305	1	10,00	15,00
GDB-40K D	2,950	405	405	405	405	1,5	23,00	35,00
GDB-50K D	4,200	506	506	506	506	1,5	33,00	50,00
GDB-60K D	5,700	606	606	606	606	1,5	45,00	68,00

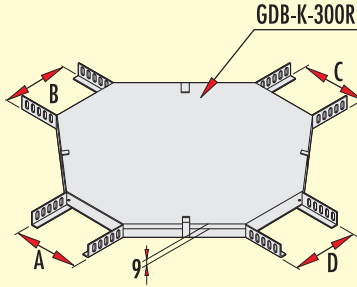

GDB-K 300R D

Dörtlü Bağlantı Kapağı 300 Radüs Crossings Element (Radius 300)

Крестообразные соединительные элементы (Радиус 300)

Sipariş kodu Order code Код заявки	Ağırlık (Kg/ad.) Weight (Kg/unit) Вес (кг/шт)	A mm	B mm	C mm	D mm	e mm	Price list прайс-лист шт/у.е.	
							Pre-Galvanized Предв. Цинк-ия	Hot dip Galvanized гор.оцинк. HDZ
GDB-5K 300R D	1,000	54	54	54	54	1	8,00	12,00
GDB-10K 300R D	1,400	104	104	104	104	1	11,00	17,00
GDB-20K 300R D	2,300	205	205	205	205	1	18,00	27,00
GDB-30K 300R D	3,600	305	305	305	305	1	29,00	43,00
GDB-40K 300R D	7,500	405	405	405	405	1,5	60,00	90,00
GDB-50K 300R D	9,600	506	506	506	506	1,5	77,00	115,00
GDB-60K 300R D	12,100	606	606	606	606	1,5	96,80	144,00

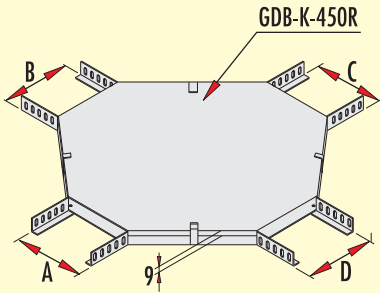

GDB-K 450R D

Dörtlü Bağlantı Kapağı 450 Radüs Crossings Element (Radius 450)

Крестообразные соединительные элементы (Радиус 450)

Sipariş kodu Order code Код заявки	Ağırlık (Kg/ad.) Weight (Kg/unit) Вес (кг/шт)	A mm	B mm	C mm	D mm	e mm	Price list прайс-лист шт/у.е.	
							Pre-Galvanized Предв. Цинк-ия	Hot dip Galvanized гор.оцинк. HDZ
GDB-5K 450R D	1,800	54	54	54	54	1	14,00	21,00
GDB-10K 450R D	2,350	104	104	104	104	1	19,00	28,00
GDB-20K 450R D	3,700	205	205	205	205	1	29,00	44,00
GDB-30K 450R D	5,100	305	305	305	305	1	40,00	60,00
GDB-40K 450R D	10,150	405	405	405	405	1,5	80,00	120,00
GDB-50K 450R D	12,800	506	506	506	506	1,5	102,00	153,00
GDB-60K 450R D	15,800	606	606	606	606	1,5	126,00	189,00

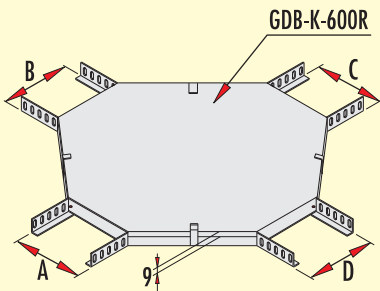

GDB-K 600R D

Dörtlü Bağlantı Kapağı 600 Radüs Crossings Element (Radius 600)

Крестообразные соединительные элементы (Радиус 600)

Sipariş kodu Order code Код заявки	Ağırlık (Kg/ad.) Weight (Kg/unit) Вес (кг/шт)	A mm	B mm	C mm	D mm	e mm	Price list прайс-лист шт/у.е.	
							Pre-Galvanized Предв. Цинк-ия	Hot dip Galvanized гор.оцинк. HDZ
GDB-5K 600R D	2,400	54	54	54	54	1	19,00	29,00
GDB-10K 600R D	3,600	104	104	104	104	1	29,00	43,00
GDB-20K 600R D	5,400	205	205	205	205	1	43,00	65,00
GDB-30K 600R D	7,150	305	305	305	305	1	57,00	86,00
GDB-40K 600R D	13,550	405	405	405	405	1,5	108,00	162,00
GDB-50K 600R D	16,700	506	506	506	506	1,5	133,00	200,00
GDB-60K 600R D	20,000	606	606	606	606	1,5	160,00	240,00

Kaplama : TS 914 EN ISO-1461 (BS-EN-ISO-1461) Sıcak Daldırma Galvaniz. Bu Ürünler İsteğe Bağlı Olarak Pregalvaniz ve CORTEN-A Saçdan İmal Edilebilir.

Coating : TS 914 EN ISO-1461 (BS-EN-ISO-1461) Hot Dip Galvanized. These products can be produced from Pregalvanized or CORTEN-A Steel according to the requirements.

Talep üzerine tüm ürünler RODINA 50® malzemesi ile kaplanarak (max) 400°C ısıya, asit, tuz ve kum etkilerine karşı mukavemet sağlar.

In case of required all type of materials can be coated with RODINA 50® which will give on extra resistant at effect of 400°C heat, acid, salt and sand for the material.

## 135° DÖNÜŞ ELEMANI VE KAPAĞI

## 135° Flat Bend and Cover

Плоский Изгиб и Покрытие 135°

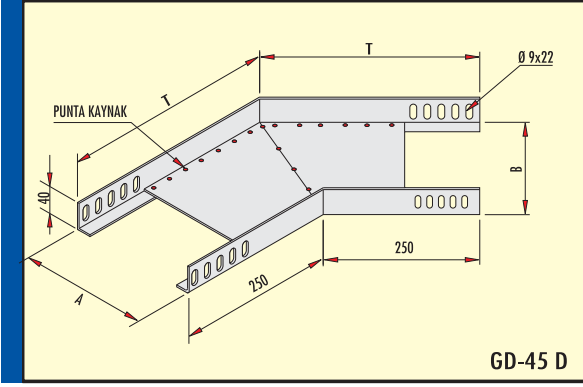

### 135° Dönüş Elemanı (h=40 mm) 135° Flat Bend (h=40 mm)

Плоский Изгиб 135°

Sipariş kodu Order code Код заявки	Ağırlık (Kg/ad.) Weight (Kg/unit) Вес (кг/шт)	A mm	B mm	T mm	e mm	Price list прайс-лист шт./у.е.	
						Pre-Galvanized Предв. Цинк-ия	Hot dip Galvanized гор.оцинк. HDZ
GD-5 45 D	0,400	54	54	271	1	3,20	4,80
GD-10 45 D	0,750	104	104	291	1,5	6,00	9,00
GD-20 45 D	1,600	205	205	333	1,5	13,00	19,00
GD-30 45 D	3,000	305	305	374	2	24,00	36,00
GD-40 45 D	3,250	405	405	416	2	26,00	39,00
GD-50 45 D	4,950	506	506	457	2	40,00	59,00
GD-60 45 D	5,650	606	606	499	2	45,00	68,00

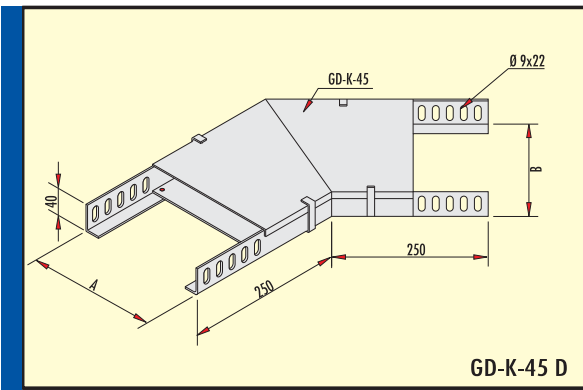

### 135° Dönüş Kapağı 135° Flat Bend Cover

Плоский Изгиб Покрытие 135°

Sipariş kodu Order code Код заявки	Ağırlık (Kg/ad.) Weight (Kg/unit) Вес (кг/шт)	A mm	h mm	e mm	Price list прайс-лист шт./у.е.	
					Pre-Galvanized Предв. Цинк-ия	Hot dip Galvanized гор.оцинк. HDZ
GD-5K - 45 D	0,200	54	54	1	1,60	2,40
GD-10K - 45 D	0,300	104	104	1	2,40	3,60
GD-20K - 45 D	0,650	205	205	1	5,20	7,80
GD-30K - 45 D	1,000	305	305	1	8,00	12,00
GD-40K - 45 D	2,300	405	405	1,5	18,00	27,00
GD-50K - 45 D	3,150	506	506	1,5	25,00	38,00
GD-60K - 45 D	4,300	606	606	1,5	34,00	51,00

## İÇ-DİŞ BÜKEY ELEMANI VE KAPAĞI

Внутренний и Наружный Вертикальный Угол С Крышкой

## Inside and Outside Vertical Bend and Covers

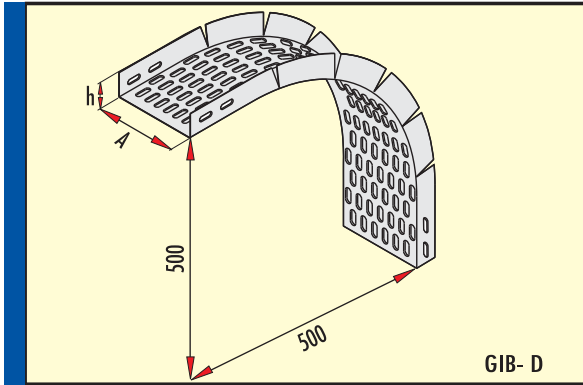

### İç-Dış Bükey Elemanı (h= 40 mm) Inside and Outside Vertical Bend (h= 40 mm)

Внутренний и Наружный Вертикальный Угол

Sipariş kodu Order code Код заявки	Ağırlık (Kg/ad.) Weight (Kg/unit) Вес (кг/шт)	A mm	h mm	e mm	Price list прайс-лист шт./у.е.	
					Pre-Galvanized Предв. Цинк-ия	Hot dip Galvanized гор.оцинк. HDZ
GIB - 5 D	1,250	50	40	1,5	10,00	15,00
GIB - 10 D	1,750	100	40	1,5	14,00	21,00
GIB - 20 D	2,650	200	40	1,5	21,20	31,80
GIB - 30 D	4,800	300	40	2	38,40	57,60
GIB - 40 D	5,850	400	40	2	46,80	70,20
GIB - 50 D	7,150	500	40	2	57,20	85,80
GIB - 60 D	8,500	600	40	2	68,00	102,00

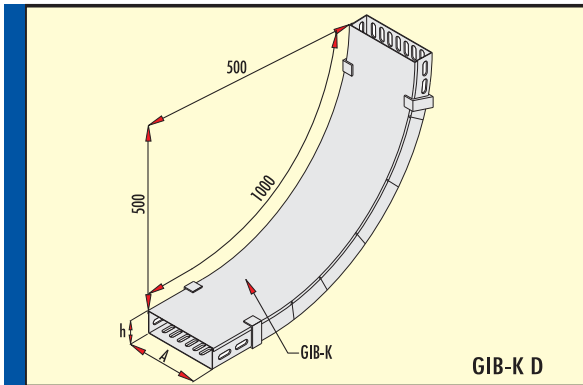

### İç-Dış Bükey Kapağı Inside and Outside Vertical Bend Cover

Крышка Внутреннего-Наружного Угла

Sipariş kodu Order code Код заявки	Ağırlık (Kg/ad.) Weight (Kg/unit) Вес (кг/шт)	A mm	h mm	e mm	Price list прайс-лист шт./у.е.	
					Pre-Galvanized Предв. Цинк-ия	Hot dip Galvanized гор.оцинк. HDZ
GIB - 5K D	0,600	50	9	1	4,80	7,20
GIB - 10K D	0,950	100	9	1	7,60	11,40
GIB - 20K D	1,600	200	9	1	12,80	19,20
GIB - 30K D	2,500	300	9	1	20,00	30,00
GIB - 40K D	4,800	400	9	1,5	38,40	57,60
GIB - 50K D	6,050	500	9	1,5	48,40	72,60
GIB - 60K D	7,200	600	9	1,5	57,60	86,40

Kaplama : TS 914 EN ISO-1461 (BS-EN-ISO-1461) Sıcak Daldırma Galvaniz.  
Bu ürünler isteğe bağlı olarak Pregalvaniz ve CORTEN-A Saçdan İmal Edilebilir.

Coating : TS 914 EN ISO-1461 (BS-EN-ISO-1461) Hot Dip Galvanized

These products can be produced from Pregalvanized or CORTEN-A Steel according to the requirements.

Talep üzerine tüm ürünler RODINA 50® malzemesi ile kaplanarak (max) 400°C ısıya, asit, tuz ve kum etkilerine karşı mukavemet sağlar.

In case of required all type of materials can be coated with RODINA 50® which will give on extra resistant at effect of 400°C heat, acid, salt and sand for the material.

## RADÜSLÜ DÖNÜŞ ELEMANLARI

### Flat Bends

### Вертикальный Наружный Угол

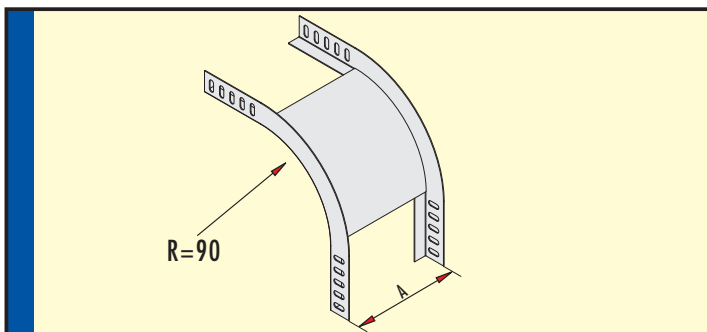
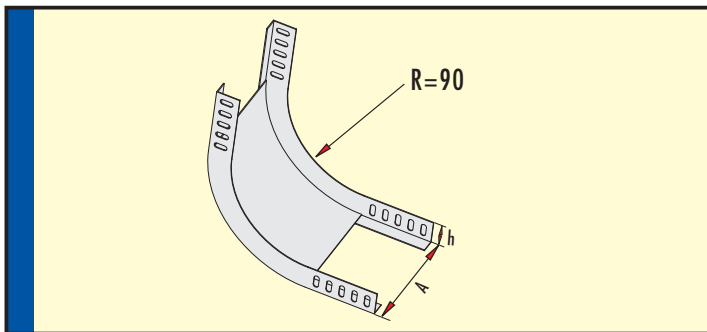
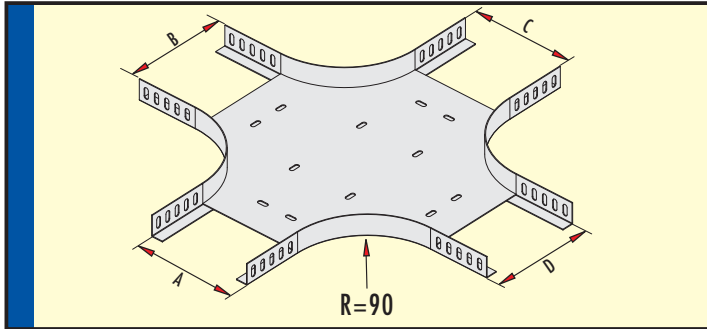
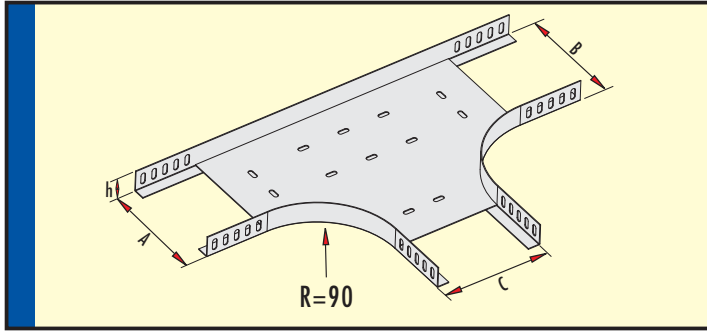
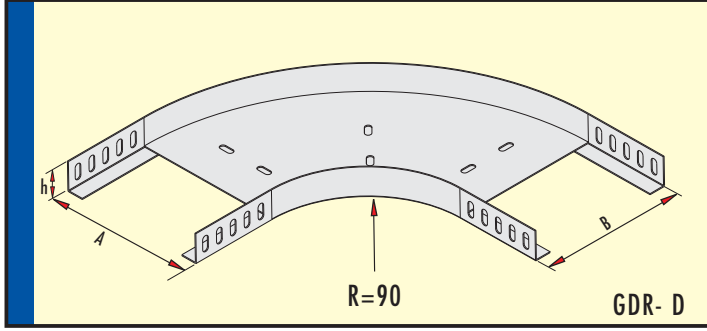

#### 90° Dönüş Elemanı 90° Flat Bend угловые элементы 90°

Sipariş kodu Order code Код заявки	Ağırlık (Kg/ad.) Weight (Kg/unit) Вес (кг/шт)	A-B mm	h mm	e mm	Price list прайс-лист шт/у.е.	
					Pre-Galvanized Предв. Цинк-ия	Hot dip Galvanized гор.оцинк. HDZ
GDR - 5 D	0,600	55	40	1,5		7,20
GDR - 10 D	0,950	105	40	1,5		11,40
GDR - 20 D	1,520	205	40	1,5		18,24
GDR - 30 D	3,030	305	40	2		36,36
GDR - 40 D	4,280	405	40	2		51,36
GDR - 50 D	5,780	505	40	2		69,36
GDR - 60 D	7,530	605	40	2		90,36

#### T Bağlantı Elemanı Tees "T"

«Т» образные соединительные элементы

Sipariş kodu Order code Код заявки	Ağırlık (Kg/ad.) Weight (Kg/unit) Вес (кг/шт)	A-B-C mm	h mm	e mm	Price list прайс-лист шт/у.е.	
					Pre-Galvanized Предв. Цинк-ия	Hot dip Galvanized гор.оцинк. HDZ
GTR-5D	1,100	55	40	1,5		13,20
GTR-10D	1,460	105	40	1,5		17,52
GTR-20D	1,220	205	40	1,5		14,64
GTR-30D	4,280	305	40	2		51,36
GTR-40D	5,910	405	40	2		70,92
GTR-50D	7,870	505	40	2		94,44
GTR-60D	10,140	605	40	2		121,68

#### Dörtlü Bağlantı Elemanı Crossing Element

крестообразные соединительные элементы

Sipariş kodu Order code Код заявки	Ağırlık (Kg/ad.) Weight (Kg/unit) Вес (кг/шт)	A-B-C-D mm	h mm	e mm	Price list прайс-лист шт/у.е.	
					Pre-Galvanized Предв. Цинк-ия	Hot dip Galvanized гор.оцинк. HDZ
GDBR - 5D	1,400	55	40	1,5		16,80
GDBR - 10D	1,800	105	40	1,5		21,60
GDBR - 20D	2,590	205	40	1,5		31,08
GDBR - 30D	4,680	305	40	2		56,16
GDBR - 40D	6,360	405	40	2		76,32
GDBR - 50D	8,360	505	40	2		100,32
GDBR - 60D	10,670	605	40	2		128,04

#### İç Bükey Elemanı Inside Vertical Bend

Вертикальный Внутренний Угол

Sipariş kodu Order code Код заявки	Ağırlık (Kg/ad.) Weight (Kg/unit) Вес (кг/шт)	A mm	h mm	e mm	Price list прайс-лист шт/у.е.	
					Pre-Galvanized Предв. Цинк-ия	Hot dip Galvanized гор.оцинк. HDZ
GIBR - 5D	0,610	55	40	1,5		7,32
GIBR - 10D	0,850	105	40	1,5		10,20
GIBR - 20D	1,090	205	40	1,5		13,08
GIBR - 30D	1,760	305	40	2		21,12
GIBR - 40D	2,070	405	40	2		24,84
GIBR - 50D	2,390	505	40	2		28,68
GIBR - 60D	2,700	605	40	2		32,40

#### Dış Bükey Elemanı Outside Vertical Bend

Вертикальный Наружный Угол

Sipariş kodu Order code Код заявки	Ağırlık (Kg/ad.) Weight (Kg/unit) Вес (кг/шт)	A mm	h mm	e mm	Price list прайс-лист шт/у.е.	
					Pre-Galvanized Предв. Цинк-ия	Hot dip Galvanized гор.оцинк. HDZ
GIBDR - 5D	0,680	55	40	1,5		8,16
GIBDR - 10D	0,750	105	40	1,5		9,00
GIBDR - 20D	0,920	205	40	1,5		11,04
GIBDR - 30D	1,470	305	40	2		17,64
GIBDR - 40D	1,700	405	40	2		20,40
GIBDR - 50D	1,930	505	40	2		23,16
GIBDR - 60D	2,160	605	40	2		25,92

Bağlantı elemanları isteğe bağlı olarak 150-300-450-600-900 Radüslü imal edilir.

Circles can be produced with ISO-300-450-600-900 Radius.



## RADÜSLÜ DÖNÜŞ ELEMAN KAPAKLARI

## Flat Bend Covers

Крышки для Углов с Плавным Переходом

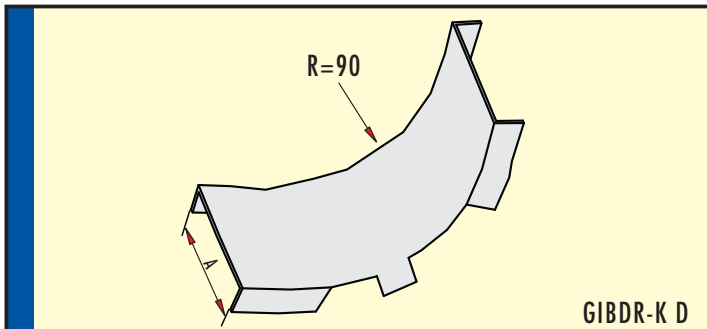
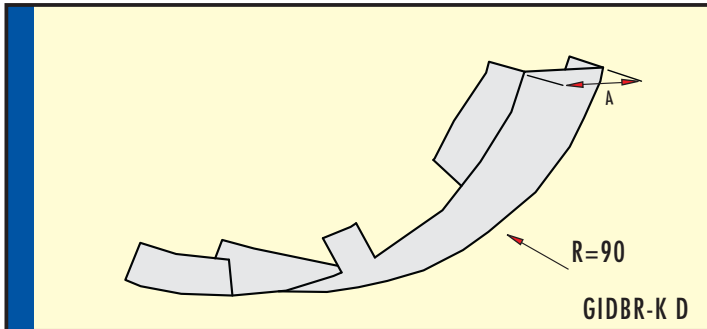
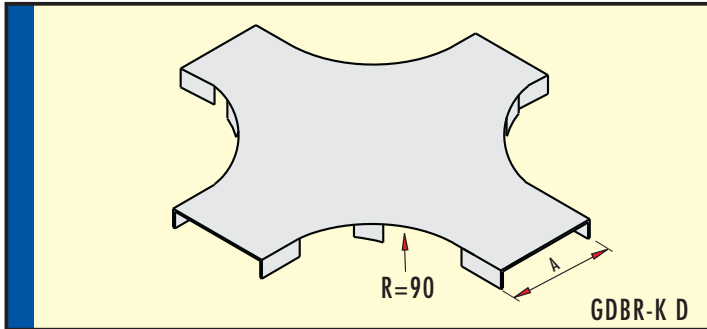
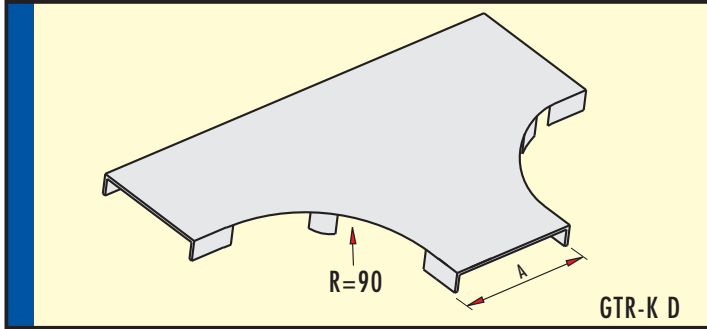
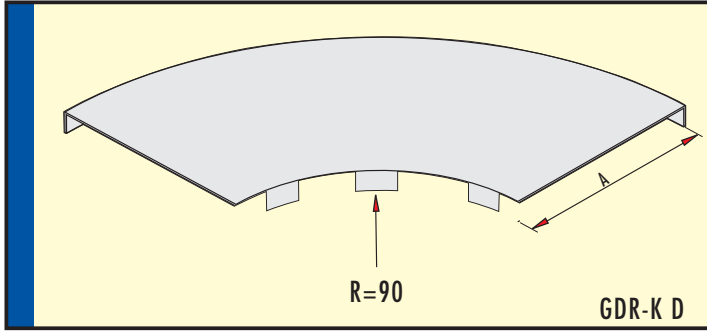

### 90° Dönüş Kapağı 90° Flat Cover

Крышка для угла 90°

Sipariş kodu Order code Код заявки	Ağırlık (Kg/ad.) Weight (Kg/unit) Вес (кг/шт)	A mm	e mm	Price list прайс-лист шт./у.е.	
				Pre-Galvanized Предв. Цинк-ия	Hot dip Galvanized гор.оцинк. HDZ
GDR - 5K D	0,160	55	1		1,92
GDR - 10K D	0,220	105	1		2,64
GDR - 20K D	0,540	205	1		6,48
GDR - 30K D	0,980	305	1		11,76
GDR - 40K D	2,340	405	1.5		28,08
GDR - 50K D	3,370	505	1.5		40,44
GDR - 60K D	4,600	605	1.5		55,20

### T Bağlantı Elemanı Kapağı Tees "T" Cover

«Т» образные соединительные элементы

Sipariş kodu Order code Код заявки	Ağırlık (Kg/ad.) Weight (Kg/unit) Вес (кг/шт)	A mm	e mm	Price list прайс-лист шт./у.е.	
				Pre-Galvanized Предв. Цинк-ия	Hot dip Galvanized гор.оцинк. HDZ
GTR-5K D	0,260	55	1		3,12
GTR-10K D	0,390	105	1		4,68
GTR-20K D	0,860	205	1		10,32
GTR-30K D	1,480	305	1		17,76
GTR-40K D	3,420	405	1.5		41,04
GTR-50K D	4,830	505	1.5		57,96
GTR-60K D	6,480	605	1.5		77,76

### Dörtlü Bağlantı Kapağı Crossing Covers

Крестообразные соединительные элементы

Sipariş kodu Order code Код заявки	Ağırlık (Kg/ad.) Weight (Kg/unit) Вес (кг/шт)	A mm	e mm	Price list прайс-лист шт./у.е.	
				Pre-Galvanized Предв. Цинк-ия	Hot dip Galvanized гор.оцинк. HDZ
GDBR-5K D	0,320	55	1		3,84
GDBR-10K D	0,490	105	1		5,88
GDBR-20K D	1,020	205	1		12,24
GDBR-30K D	1,710	305	1		20,52
GDBR-40K D	3,860	405	1.5		46,32
GDBR-50K D	5,370	505	1.5		64,44
GDBR-60K D	7,110	605	1.5		85,32

### İç Bükey Kapağı Inside Vertical Cover

Внутри и снаружи Вертикального Покрывтия Изгиба

Sipariş kodu Order code Код заявки	Ağırlık (Kg/ad.) Weight (Kg/unit) Вес (кг/шт)	A mm	e mm	Price list прайс-лист шт./у.е.	
				Pre-Galvanized Предв. Цинк-ия	Hot dip Galvanized гор.оцинк. HDZ
GIDBR-5K D	0,130	55	1		1,56
GIDBR-10K D	0,150	105	1		1,80
GIDBR-20K D	0,260	205	1		3,12
GIDBR-30K D	0,370	305	1		4,44
GIDBR-40K D	0,730	405	1.5		8,76
GIDBR-50K D	0,910	505	1.5		10,92
GIDBR-60K D	1,100	605	1.5		13,20

### Dış Bükey Kapağı Outside Vertical Bend Cover

Внутри и снаружи Вертикальных Изгибов

Sipariş kodu Order code Код заявки	Ağırlık (Kg/ad.) Weight (Kg/unit) Вес (кг/шт)	A mm	e mm	Price list прайс-лист шт./у.е.	
				Pre-Galvanized Предв. Цинк-ия	Hot dip Galvanized гор.оцинк. HDZ
GIBDR-5K D	0,110	55	1		1,32
GIBDR-10K D	0,140	105	1		1,68
GIBDR-20K D	0,250	205	1		3,00
GIBDR-30K D	0,360	305	1		4,32
GIBDR-40K D	0,710	405	1.5		8,52
GIBDR-50K D	0,880	505	1.5		10,56
GIBDR-60K D	1,050	605	1.5		12,60

Bağlantı eleman kapakları isteğe bağlı olarak 150-300-450-600-900 Radüslü imal edilir. Curved bend covers can be produced with ISO-300-450-600-900 Radius.

AĞIR HİZMET TİP KABLO KANALLARI Heavy Duty Cable Trays

Сверхмощные кабельные лотки

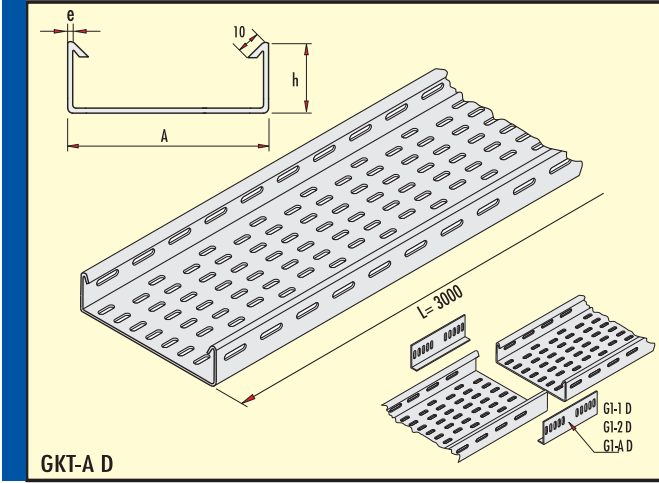

Ağır Hizmet Tipi Kablo Kanalı (h=40 mm)  
Heavy Duty Cable Tray (h=40 mm)

Сверхмощные кабельные лотки

Sipariş kodu Order code Код заявки	Ağırlık (Kg/mt.) Weight (Kg/mt) Вес (кг/м)	A mm	h mm	e mm	Price list прайс-лист М/у.е.	
					Pre-Galvanized Предв. Цинк-ия	Hot dip Galvanized гор.оцинк. HDZ
GKT-A5 D	1,100	50	40	1	5,50	9,90
GKT-A10-1 D	1,450	100	40	1	7,00	13,05
GKT-A10-2 D	2,100	100	40	1,5	10,50	18,90
GKT-A10-3 D	1,700	100	40	1,2	8,50	15,30
GKT-A20 D	3,300	200	40	1,5	16,50	29,70
GKT-A20-1 D	2,640	200	40	1,2	13,20	23,80
GKT-A30-1 D	4,200	300	40	1,5	21,00	37,80
GKT-A30-2 D	5,600	300	40	2	28,00	50,40
GKT-A40 D	6,850	400	40	2	34,20	61,65
GKT-A50 D	9,000	500	40	2	45,00	81,00
GKT-A60 D	10,050	600	40	2	50,20	90,45

DELİKSİZ AĞIR HİZMET KAPAKLI TİP KABLO KANALLARI  
Сверхмощные кабельные лотки с крышкой

Non Perforated Heavy Duty Cable Trays With Cover

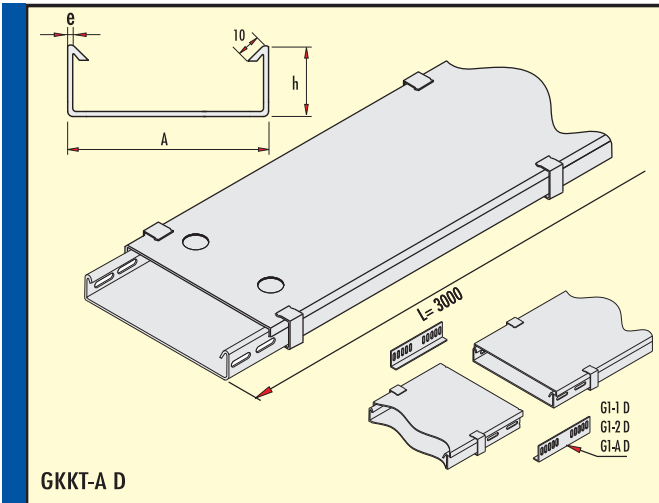

Deliksiz Ağır Hizmet Tipi Kablo Kanalı (h=40 mm)

Non Perforated Heavy Duty Cable Trays With Cover (h=40 mm)

Неперфорированные Сверхмощные Кабельные Лотки С Крышкой

Sipariş kodu Order code Код заявки	Ağırlık (Kg/mt.) Weight (Kg/mt) Вес (кг/м)	A mm	h mm	e mm	Price list прайс-лист М/у.е.	
					Pre-Galvanized Предв. Цинк-ия	Hot dip Galvanized гор.оцинк. HDZ
GKKT-A5 D	1,900	50	40	1	7,60	15,20
GKKT-A10-1 D	2,700	100	40	1	11,00	22,00
GKKT-A10-2 D	4,050	100	40	1,5	16,20	32,40
GKKT-A10-3 D	3,350	100	40	1,2	13,40	26,80
GKKT-A20 D	5,550	200	40	1,5	22,20	44,40
GKKT-A20-1 D	4,450	200	40	1,2	17,80	35,60
GKKT-A30-1 D	7,850	300	40	1,5	31,40	62,80
GKKT-A30-2 D	9,700	300	40	2	38,80	77,60
GKKT-A40 D	14,000	400	40	2	56,00	112,00
GKKT-A50 D	17,000	500	40	2	68,00	136,00
GKKT-A60 D	19,950	600	40	2	79,80	159,60

EK PARÇASI Jointing Piece

Соединительные элементы

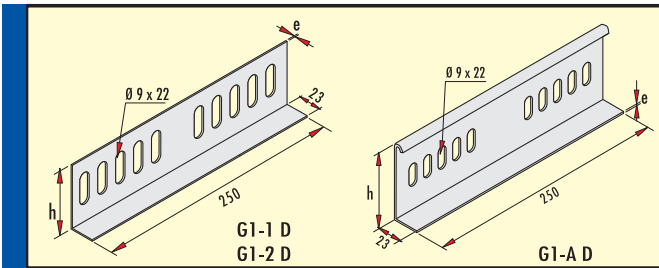

Ek Parçası (h=40 mm)  
Jointing Piece (h=40 mm)

Соединительные элементы

Sipariş kodu Order code Код заявки	Ağırlık (Kg/ad.) Weight (Kg/unit) Вес (кг/шт)	h mm	e mm	Price list прайс-лист шт/у.е.	
				Pre-Galvanized Предв. Цинк-ия	Hot dip Galvanized гор.оцинк. HDZ
G1-1 D	0,160	40	1,5	1,60	2,20
G1-2 D	0,200	40	2	2,00	2,80
G1-A D	0,270	44	2	2,70	3,80

İsteğe bağlı olarak A tipi h=50 mm imal edilebilir. A type may be produced as h=50 mm due to request.  
при необходимости тип А может быть изготовлен с h=50 мм.

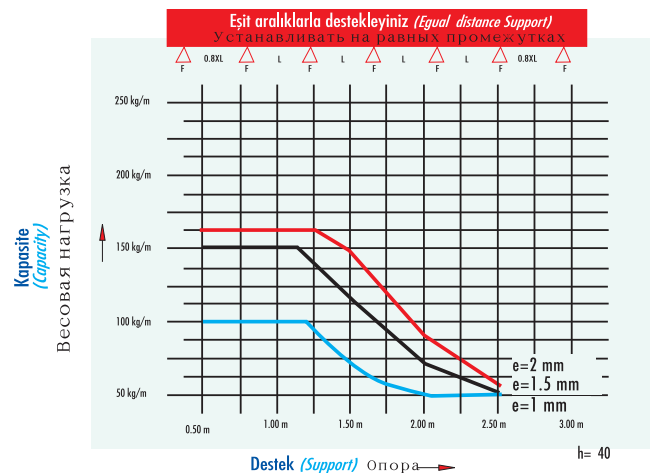

Kaplama : TS 914 EN ISO-1461 (BS-EN-ISO-1461) Sıcak Daldırma Galvaniz.

Coating : TS 914 EN ISO-1461 (BS-EN-ISO-1461) Hot Dip Galvanized

Bu Ürünler İsteğe Bağlı Olarak Pregalvaniz ve CORTEN-A Saçdan İmal Edilebilir.

These products can be produced from Pregalvanized or CORTEN-A Steel according to the requirements.

Talep üzerine tüm ürünler RODINA 50® malzemesi ile kaplanarak (max) 400°C ısıya, asit, tuz ve kum etkilerine karşı mukavemet sağlar.

In case of required all type of materials can be coated with RODINA 50® which will give on extra resistant at effect of 400°C heat, acid, salt and sand for the material.

ĞİR HİZMET 90° DÖNÜŞ ELEMANLARI

90° Heavy Duty Flat Bends

Сверхмощные угловые элементы 90°

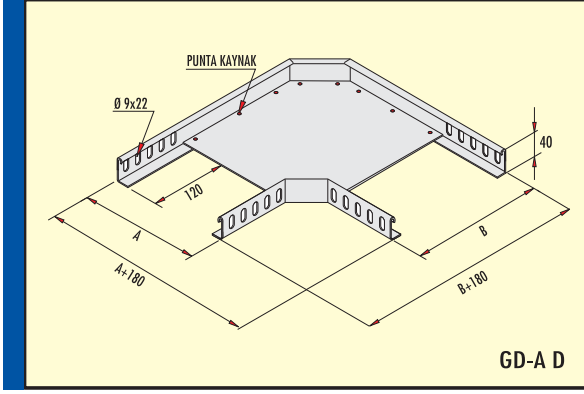

Ğır Hizmet 90° Dönüş Elemanı (h=40 mm)  
90° Heavy Duty Flat Bend (h=40 mm)  
Сверхмощные угловые элементы 90°

Sipariş kodu Order code Код заявки	Ağırlık (Kg/ad.) Weight (Kg/unit) Вес (кг/шт)	A mm	B mm	e mm	Price list прайс-лист шт/у.е.	
					Pre-Galvanized Предв. Цинк-ия	Hot dip Galvanized гор.оцинк. HDZ
GD-A5 D	0,508	54	54	1	4,10	6,10
GD-A10 D	0,976	104	104	1,5	7,80	11,70
GD-A20 D	1,560	205	205	1,5	12,50	18,70
GD-A30 D	3,204	305	305	2	25,70	38,45
GD-A40 D	4,500	405	405	2	36,00	54,00
GD-A50 D	6,200	506	506	2	49,60	74,40
GD-A60 D	8,100	606	606	2	64,80	97,20

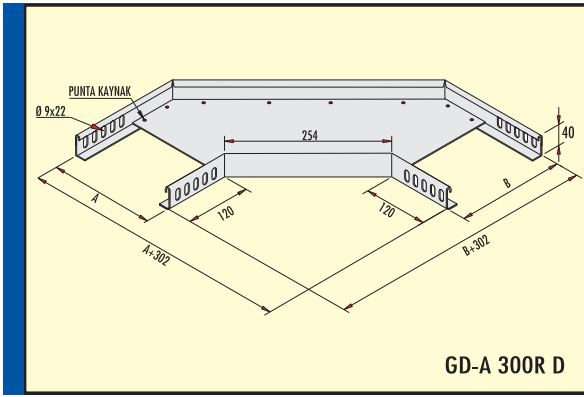

Ğır Hizmet 90° Dönüş Elemanı 300 Radüs (h=40 mm)  
90° Heavy Duty Flat Bend Radius 300 (h=40 mm)  
Сверхмощные угловые элементы 90° (Радиус 300)

Sipariş kodu Order code Код заявки	Ağırlık (Kg/ad.) Weight (Kg/unit) Вес (кг/шт)	A mm	B mm	e mm	Price list прайс-лист шт/у.е.	
					Pre-Galvanized Предв. Цинк-ия	Hot dip Galvanized гор.оцинк. HDZ
GD-A5 300R D	0,850	54	54	1	6,80	10,20
GD-A10 300R D	1,500	104	104	1,5	12,00	18,00
GD-A20 300R D	2,300	205	205	1,5	18,40	27,60
GD-A30 300R D	4,400	305	305	2	35,20	52,80
GD-A40 300R D	5,900	405	405	2	47,20	70,80
GD-A50 300R D	7,850	506	506	2	62,80	94,20
GD-A60 300R D	10,050	606	606	2	80,40	120,60

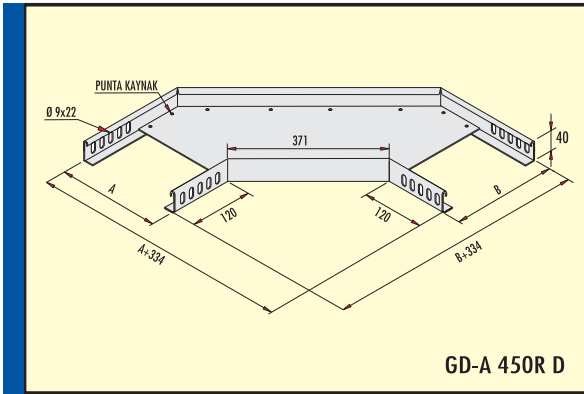

Ğır Hizmet 90° Dönüş Elemanı 450 Radüs (h=40 mm)  
90° Heavy Duty Flat Bend Radius 450 (h=40 mm)  
Сверхмощные угловые элементы 90° Радиус 450

Sipariş kodu Order code Код заявки	Ağırlık (Kg/ad.) Weight (Kg/unit) Вес (кг/шт)	A mm	B mm	e mm	Price list прайс-лист шт/у.е.	
					Pre-Galvanized Предв. Цинк-ия	Hot dip Galvanized гор.оцинк. HDZ
GD-A5 450R D	1,350	54	54	1	10,80	16,20
GD-A10 450R D	2,650	104	104	1,5	21,20	31,80
GD-A20 450R D	3,900	205	205	1,5	31,20	46,80
GD-A30 450R D	4,900	305	305	2	39,20	58,80
GD-A40 450R D	6,700	405	405	2	53,60	80,40
GD-A50 450R D	8,600	506	506	2	68,80	103,20
GD-A60 450R D	10,800	606	606	2	86,40	129,60

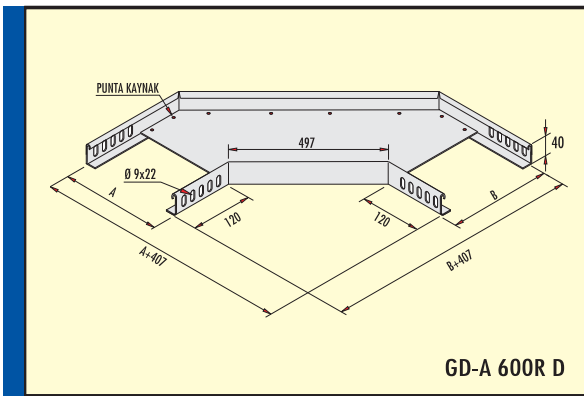

Ğır Hizmet 90° Dönüş Elemanı 600 Radüs (h=40 mm)  
90° Heavy Duty Flat Bend Radius 600 (h=40 mm)  
Сверхмощные угловые элементы 90° (Радиус 600)

Sipariş kodu Order code Код заявки	Ağırlık (Kg/ad.) Weight (Kg/unit) Вес (кг/шт)	A mm	B mm	e mm	Price list прайс-лист шт/у.е.	
					Pre-Galvanized Предв. Цинк-ия	Hot dip Galvanized гор.оцинк. HDZ
GD-A5 600R D	2,200	54	54	1	17,60	26,40
GD-A10 600R D	3,150	104	104	1,5	25,20	37,80
GD-A20 600R D	4,800	205	205	1,5	38,40	57,60
GD-A30 600R D	6,200	305	305	2	49,60	74,40
GD-A40 600R D	8,200	405	405	2	65,60	98,40
GD-A50 600R D	9,700	506	506	2	77,60	116,40
GD-A60 600R D	10,900	606	606	2	87,20	130,80

Kaplama : TS 914 EN ISO-1461 (BS-EN-ISO-1461) Sıcak Daldırma Galvaniz.  
Bu ürünler isteğe bağlı olarak Pregalvaniz ve CORTEN-A Saçdan İmal Edilebilir.

Coating : TS 914 EN ISO-1461 (BS-EN-ISO-1461) Hot Dip Galvanized  
These products can be produced from Pregalvanized or CORTEN-A Steel according to the requirements.

Talep üzerine tüm ürünler RODINA 50® malzemesi ile kaplanarak (max) 400°C ısıya, asit, tuz ve kum etkilerine karşı mukavemet sağlar.

In case of required all type of materials can be coated with RODINA 50® which will give on extra resistant at effect of 400°C heat, acid, salt and sand for the material.



## AĞIR HİZMET T BAĞLANTI ELEMANLARI

## Heavy Duty Tees "T"

Сверхмощные «Т» образные соединительные элементы

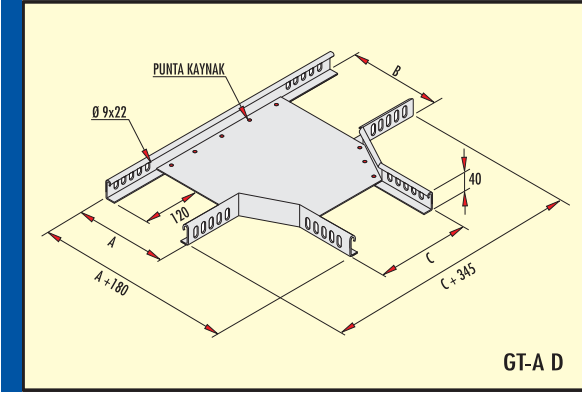

### Ağır Hizmet T Bağlantı Elemanı (h=40 mm) Heavy Duty Tees "T" (h=40 mm)

Сверхмощные «Т» образные соединительные элементы

Sipariş kodu Order code Код заявки	Ağırlık (Kg/ad.) Weight (Kg/unit) Вес (кг/шт)	A mm	B mm	C mm	e mm	Price list прайс-лист шт/у.е.	
						Pre-Galvanized Предв. Цинк-ия	Hot dip Galvanized гор.оцинк. HDZ
GT - A5 D	0,680	54	54	54	1	5,50	8,00
GT - A10 D	1,300	104	104	104	1,5	10,50	15,00
GT - A20 D	1,850	205	205	205	1,5	15,00	22,00
GT - A30 D	3,600	305	305	305	2	29,00	43,00
GT - A40 D	5,100	405	405	405	2	41,00	61,00
GT - A50 D	6,800	506	506	506	2	54,00	81,00
GT - A60 D	8,900	606	606	606	2	71,00	108,00

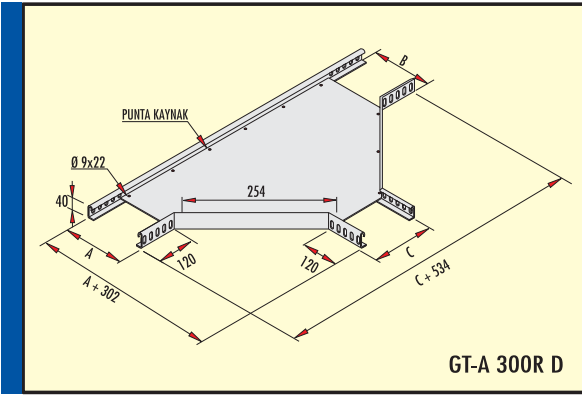

### Ağır Hizmet T Bağlantı Elemanı 300 Radüs (h=40 mm) Heavy Duty Tees "T" Radius 300 (h=40 mm)

Сверхмощные «Т» образные соединительные элементы (Радиус 300)

Sipariş kodu Order code Код заявки	Ağırlık (Kg/ad.) Weight (Kg/unit) Вес (кг/шт)	A mm	B mm	C mm	e mm	Price list прайс-лист шт/у.е.	
						Pre-Galvanized Предв. Цинк-ия	Hot dip Galvanized гор.оцинк. HDZ
GT - A5 300R D	1,550	54	54	54	1	12,40	18,60
GT - A10 300R D	2,650	104	104	104	1,5	21,00	32,00
GT - A20 300R D	4,000	205	205	205	1,5	32,00	48,00
GT - A30 300R D	7,200	305	305	305	2	57,00	86,00
GT - A40 300R D	9,500	405	405	405	2	76,00	114,00
GT - A50 300R D	11,850	506	506	506	2	95,00	142,00
GT - A60 300R D	14,700	606	606	606	2	117,00	176,00

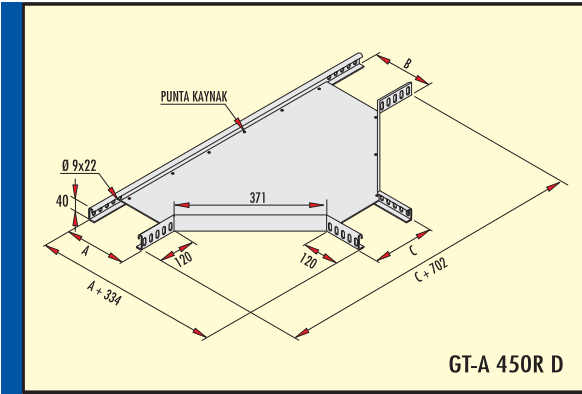

### Ağır Hizmet T Bağlantı Elemanı 450 Radüs (h=40 mm) Heavy Duty Tees "T" Radius 450 (h=40 mm)

Сверхмощные «Т» образные соединительные элементы (Радиус 450)

Sipariş kodu Order code Код заявки	Ağırlık (Kg/ad.) Weight (Kg/unit) Вес (кг/шт)	A mm	B mm	C mm	e mm	Price list прайс-лист шт/у.е.	
						Pre-Galvanized Предв. Цинк-ия	Hot dip Galvanized гор.оцинк. HDZ
GT - A5 450R D	2,700	54	54	54	1	21,00	32,00
GT - A10 450R D	3,600	104	104	104	1,5	29,00	43,00
GT - A20 450R D	5,850	205	205	205	1,5	47,00	70,00
GT - A30 450R D	10,300	305	305	305	2	81,00	120,00
GT - A40 450R D	13,100	405	405	405	2	104,00	156,00
GT - A50 450R D	15,150	506	506	506	2	120,00	181,00
GT - A60 450R D	18,400	606	606	606	2	145,00	217,00

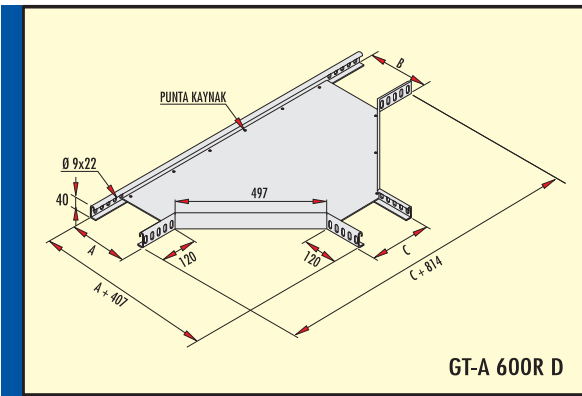

### Ağır Hizmet T Bağlantı Elemanı 600 Radüs (h=40 mm) Heavy Duty Tees "T" Radius 600 (h=40 mm)

Сверхмощные «Т» образные соединительные элементы (Радиус 600)

Sipariş kodu Order code Код заявки	Ağırlık (Kg/ad.) Weight (Kg/unit) Вес (кг/шт)	A mm	B mm	C mm	e mm	Price list прайс-лист шт/у.е.	
						Pre-Galvanized Предв. Цинк-ия	Hot dip Galvanized гор.оцинк. HDZ
GT - A5 600R D	4,400	54	54	54	1	35,00	53,00
GT - A10 600R D	5,250	104	104	104	1,5	42,00	63,00
GT - A20 600R D	7,750	205	205	205	1,5	61,00	93,00
GT - A30 600R D	13,250	305	305	305	2	106,00	159,00
GT - A40 600R D	16,600	405	405	405	2	130,00	200,00
GT - A50 600R D	18,750	506	506	506	2	150,00	225,00
GT - A60 600R D	22,550	606	606	606	2	180,00	270,00

Kaplama : TS 914 EN ISO-1461 (BS-EN-ISO-1461) Sıcak Daldırma Galvaniz.  
Bu Ürünler İsteğe Bağlı Olarak Pregalvaniz ve CORTEN-A Saçdan İmal Edilebilir.

Coating : TS 914 EN ISO-1461 (BS-EN-ISO-1461) Hot Dip Galvanized  
These products can be produced from Pregalvanized or CORTEN-A Steel according to the requirements.

Talep üzerine tüm ürünler RODINA 50® malzemesi ile kaplanarak (max) 400°C ısıya, asit, tuz ve kum etkilerine karşı mukavemet sağlar.

In case of required all type of materials can be coated with RODINA 50® which will give on extra resistant at effect of 400°C heat, acid, salt and sand for the material.

**AĞIR HİZMET DÖRTLÜ BAĞLANTI ELEMANI** Heavy Duty Crossing  
Сверхмощные крестообразные соединительные элементы

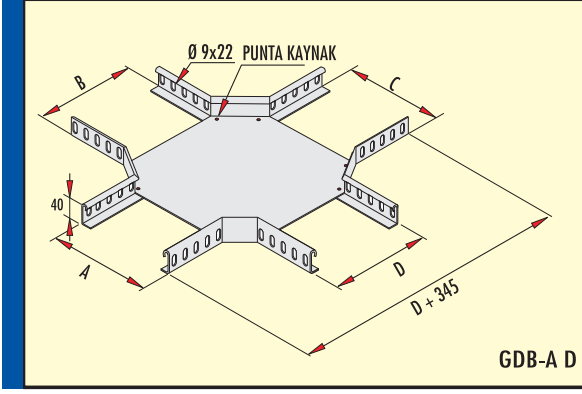

**Ağır Hizmet Dörtlü Bağlantı Elemanı (h=40 mm)**  
Heavy Duty Crossing (h=40 mm)

Сверхмощные крестообразные соединительные элементы

Sipariş kodu Order code Код заявки	Ağırlık (Kg/ad.) Weight (Kg/unit) Вес (кг / шт)	A mm	B mm	C mm	D mm	e mm	Price list прайс-лист шт / у.е.	
							Pre-Galvanized Предв. Цинк-ия	Hot dip Galvanized гор.оцинк. HDZ
GDB- A5 D	0,850	54	54	54	54	1	6,80	10,00
GDB- A10 D	1,430	104	104	104	104	1,5	11,40	17,00
GDB- A20 D	2,200	205	205	205	205	1,5	17,60	26,00
GDB- A30 D	4,130	305	305	305	305	2	33,00	49,00
GDB- A40 D	6,600	405	405	405	405	2	52,80	79,00
GDB- A50 D	7,500	506	506	506	506	2	60,00	90,00
GDB- A60 D	9,600	606	606	606	606	2	77,00	115,00

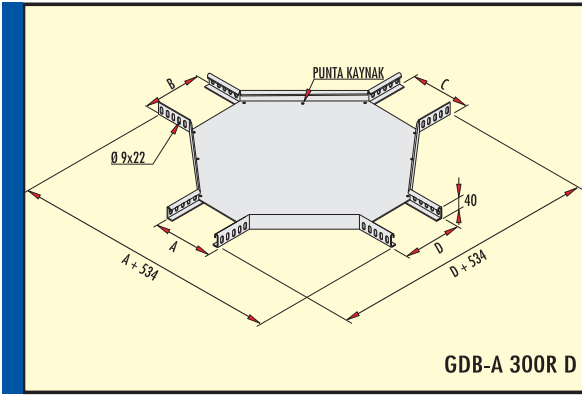

**Ağır Hizmet Dörtlü Bağlantı Elemanı 300 Radüs (h=40 mm)**  
Heavy Duty Crossing Radius 300 (h=40 mm)

Сверхмощные крестообразные соединительные элементы (Радиус 300)

Sipariş kodu Order code Код заявки	Ağırlık (Kg/ad.) Weight (Kg/unit) Вес (кг / шт)	A mm	B mm	C mm	D mm	e mm	Price list прайс-лист шт / у.е.	
							Pre-Galvanized Предв. Цинк-ия	Hot dip Galvanized гор.оцинк. HDZ
GDB- A5 300R D	1,800	54	54	54	54	1	14,40	21,00
GDB- A10 300R D	3,220	104	104	104	104	1,5	26,00	38,00
GDB- A20 300R D	4,850	205	205	205	205	1,5	39,00	58,00
GDB- A30 300R D	8,450	305	305	305	305	2	67,00	101,00
GDB- A40 300R D	10,900	405	405	405	405	2	87,00	130,00
GDB- A50 300R D	13,500	506	506	506	506	2	108,00	162,00
GDB- A60 300R D	16,700	606	606	606	606	2	133,00	200,00

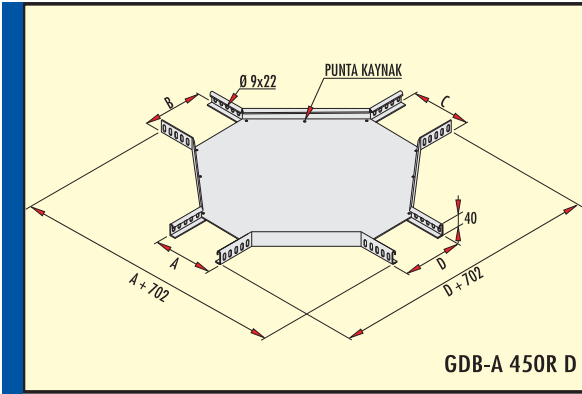

**Ağır Hizmet Dörtlü Bağlantı Elemanı 450 Radüs (h=40 mm)**  
Heavy Duty Crossing Radius 450 (h=40 mm)

Сверхмощные крестообразные соединительные элементы (Радиус 450)

Sipariş kodu Order code Код заявки	Ağırlık (Kg/ad.) Weight (Kg/unit) Вес (кг / шт)	A mm	B mm	C mm	D mm	e mm	Price list прайс-лист шт / у.е.	
							Pre-Galvanized Предв. Цинк-ия	Hot dip Galvanized гор.оцинк. HDZ
GDB- A5 450R D	4,200	54	54	54	54	1	33,00	50,00
GDB- A10 450R D	4,870	104	104	104	104	1,5	39,00	58,00
GDB- A20 450R D	7,150	205	205	205	205	1,5	57,00	86,00
GDB- A30 450R D	12,100	305	305	305	305	2	96,00	145,00
GDB- A40 450R D	15,300	405	405	405	405	2	122,00	183,00
GDB- A50 450R D	18,500	506	506	506	506	2	148,00	222,00
GDB- A60 450R D	22,300	606	606	606	606	2	178,00	267,00

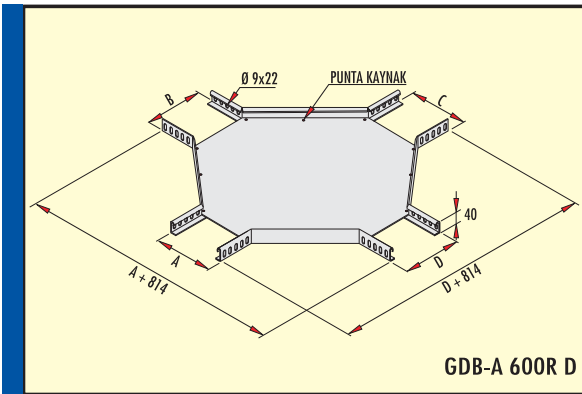

**Ağır Hizmet Dörtlü Bağlantı Elemanı 600 Radüs (h=40 mm)**  
Heavy Duty Crossing Radius 600 (h=40 mm)

Сверхмощные крестообразные соединительные элементы (Радиус 600)

Sipariş kodu Order code Код заявки	Ağırlık (Kg/ad.) Weight (Kg/unit) Вес (кг / шт)	A mm	B mm	C mm	D mm	e mm	Price list прайс-лист шт / у.е.	
							Pre-Galvanized Предв. Цинк-ия	Hot dip Galvanized гор.оцинк. HDZ
GDB- A5 600R D	5,700	54	54	54	54	1	45,00	68,00
GDB- A10 600R D	6,500	104	104	104	104	1,5	52,00	78,00
GDB- A20 600R D	9,150	205	205	205	205	1,5	73,00	110,00
GDB- A30 600R D	15,250	305	305	305	305	2	122,00	183,00
GDB- A40 600R D	18,800	405	405	405	405	2	150,00	225,00
GDB- A50 600R D	22,600	506	506	506	506	2	180,00	271,00
GDB- A60 600R D	26,850	606	606	606	606	2	214,00	322,00

Kaplama : TS 914 EN ISO-1461 (BS-EN-ISO-1461) Sıcak Daldırma Galvaniz.  
Bu Ürünler İsteğe Bağlı Olarak Pregalvaniz ve CORTEN-A Saçdan İmal Edilebilir.

Coating : TS 914 EN ISO-1461 (BS-EN-ISO-1461) Hot Dip Galvanized  
These products can be produced from Pregalvanized or CORTEN-A Steel according to the requirements.

Talep üzerine tüm ürünler RODINA 50® malzemesi ile kaplanarak (max) 400°C ısıya, asit, tuz ve kum etkilerine karşı mukavemet sağlar.  
In case of required all type of materials can be coated with RODINA 50® which will give on extra resistant at effect of 400°C heat, acid, salt and sand for the material.

## 135° AĞIR HİZMET DÖNÜŞ ELEMANI

## 135° Heavy Duty Flat Bend

Сверхмощный Поворот на 135°

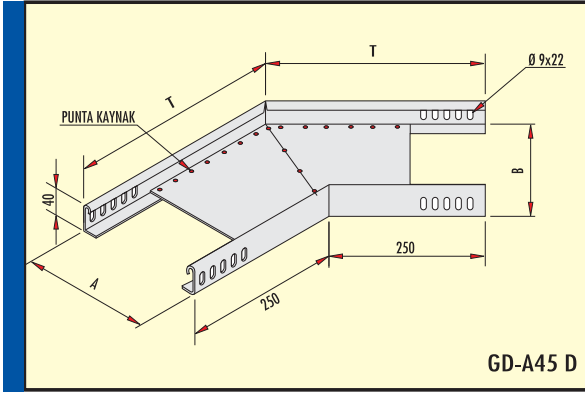

### 135° Ağır Hizmet Dönüş Elemanı (h=40 mm)

### 135° Heavy Duty Flat Bend (h=40 mm)

Сверхмощный Поворот на 135°

Sipariş kodu Order code Код заявки	Ağırlık (Kg/ad.) Weight (Kg/unit) Вес (кг/шт)	A mm	B mm	T mm	e mm	Price list прайс-лист шт/у.е.	
						Pre-Galvanized Предв. Цинк-ия	Hot dip Galvanized гор.оцинк. HDZ
GD- A5 - 45 D	0,450	54	54	271	1	3,60	5,40
GD- A10 - 45 D	0,900	104	104	291	1,5	7,50	10,80
GD- A20 - 45 D	1,800	205	205	333	1,5	14,40	21,60
GD- A30 - 45 D	3,050	305	305	374	2	24,00	36,00
GD- A40 - 45 D	3,200	405	405	416	2	26,00	40,00
GD- A50 - 45 D	5,300	506	506	457	2	40,00	63,00
GD- A60 - 45 D	6,500	606	606	499	2	48,00	78,00

## AĞIR HİZMET İÇ-DIŞ BÜKEY ELEMANI

## Heavy Duty Inside and Outside Vertical Bend

Внутри и снаружи Вертикального Изгиба и Покрытий

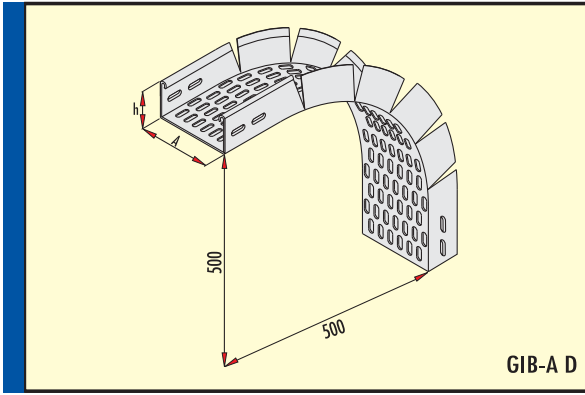

### Ağır Hizmet İç-Dış Bükey Elemanı (h=40 mm)

### Heavy Duty Inside and Outside Vertical Bend (h=40 mm)

Сверхмощный Внутренний и Наружный Вертикальный Угол

Sipariş kodu Order code Код заявки	Ağırlık (Kg/ad.) Weight (Kg/unit) Вес (кг/шт)	A mm	h mm	e mm	Price list прайс-лист шт/у.е.	
					Pre-Galvanized Предв. Цинк-ия	Hot dip Galvanized гор.оцинк. HDZ
GIB-A5 D	1,450	50	40	1,5	11,60	17,40
GIB-A10 D	1,950	100	40	1,5	15,60	23,40
GIB-A20 D	2,850	200	40	1,5	22,80	34,20
GIB-A30 D	5,050	300	40	2	40,40	60,60
GIB-A40 D	6,100	400	40	2	48,80	73,20
GIB-A50 D	7,400	500	40	2	59,20	88,80
GIB-A60 D	8,800	600	40	2	70,40	105,60

## DIKEY "T"

## Vertical "Tee"

Вертикальная "Мишень"

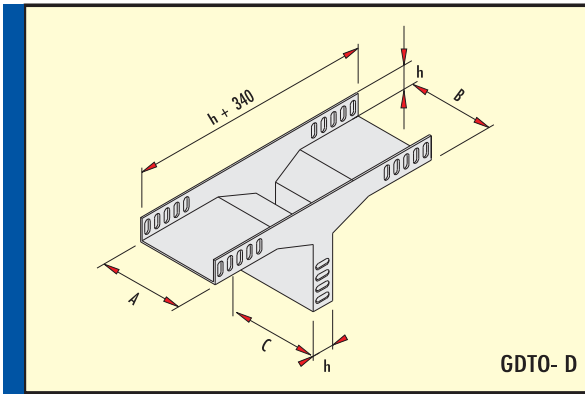

### Dikey "T" Ortadan (h=40 mm)

### Vertical "Tee" Center (h=40 mm)

Вертикальный Т-образный Элемент

Sipariş kodu Order code Код заявки	Ağırlık (Kg/ad.) Weight (Kg/unit) Вес (кг/шт)	A-B-C mm	h mm	e mm	Price list прайс-лист шт/у.е.	
					Pre-Galvanized Предв. Цинк-ия	Hot dip Galvanized гор.оцинк. HDZ
GDTO - 5 D	1,100	50	40	1,5	8,80	13,00
GDTO - 10 D	1,460	100	40	1,5	14,60	20,00
GDTO - 20 D	2,280	200	40	1,5	22,80	32,00
GDTO - 30 D	3,100	300	40	1,5	31,00	43,00
GDTO - 40 D	5,230	400	40	2	52,30	73,00
GDTO - 50 D	6,320	500	40	2	63,20	88,00
GDTO - 60 D	7,410	600	40	2	74,10	103,00

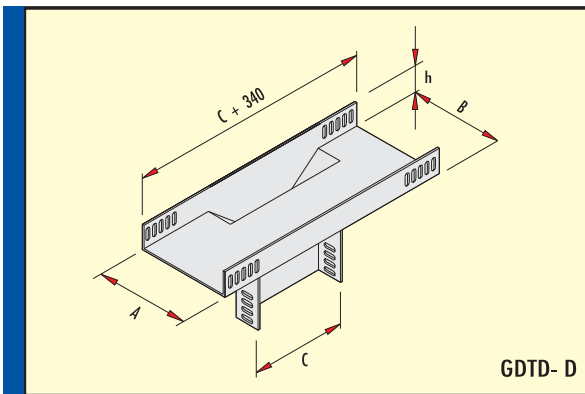

### Dikey "T" Duvardan (h=40 mm)

### Vertical "Tee" Wall (h=40 mm)

Вертикальный Т-образный Элемент (по стене)

Sipariş kodu Order code Код заявки	Ağırlık (Kg/ad.) Weight (Kg/unit) Вес (кг/шт)	A-B-C mm	h mm	e mm	Price list прайс-лист шт/у.е.	
					Pre-Galvanized Предв. Цинк-ия	Hot dip Galvanized гор.оцинк. HDZ
GDTD - 5 D	1,150	50	40	1,5	9,00	14,00
GDTD - 10 D	1,480	100	40	1,5	14,83	21,00
GDTD - 20 D	2,650	200	40	1,5	26,50	37,00
GDTD - 30 D	4,100	300	40	1,5	41,00	57,00
GDTD - 40 D	7,730	400	40	2	77,00	107,00
GDTD - 50 D	10,350	500	40	2	103,00	140,00
GDTD - 60 D	13,320	600	40	2	133,00	182,00

Kaplama : TS 914 EN ISO-1461 (BS-EN-ISO-1461) Sıcak Daldırma Galvaniz.  
Bu Ürünler İsteğe Bağlı Olarak Pregalvaniz ve CORTEN-A Saçdan İmal Edilebilir.

Coating : TS 914 EN ISO-1461 (BS-EN-ISO-1461) Hot Dip Galvanized  
These products can be produced from Pregalvanized or CORTEN-A Steel according to the requirements.

Talep üzerine tüm ürünler RODINA 50® malzemesi ile kaplanarak (max) 400°C ısıya, asit, tuz ve kum etkilerine karşı mukavemet sağlar.

In case of required all type of materials can be coated with RODINA 50® which will give on extra resistant at effect of 400°C heat, acid, salt and sand for the material.



## RADÜSLÜ DÖNÜŞ ELEMANLARI

### Flat Bends

### Углы с Плавным Переходом

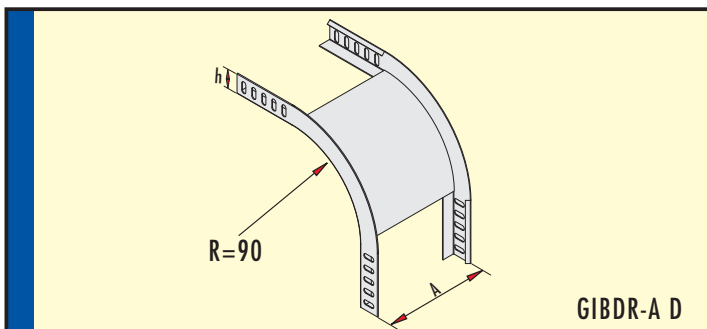
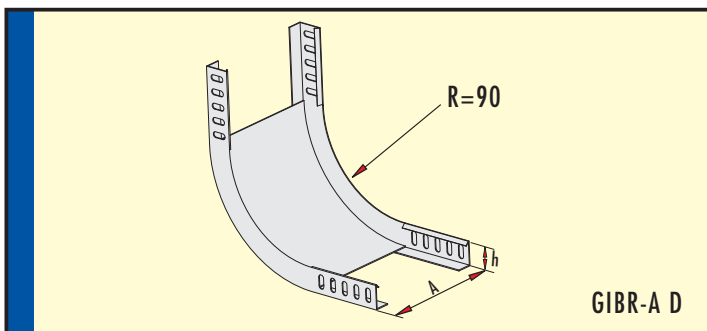
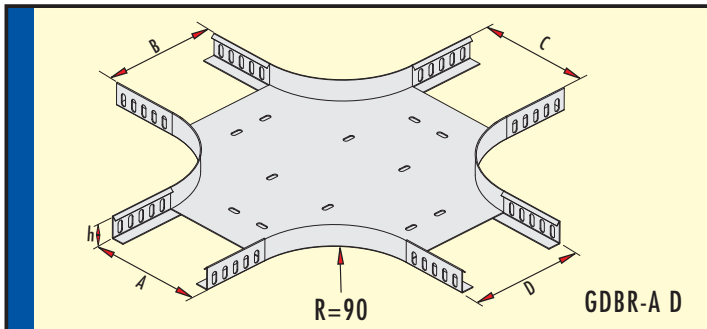
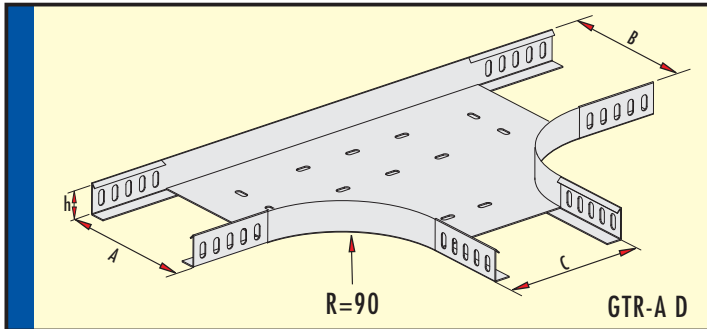
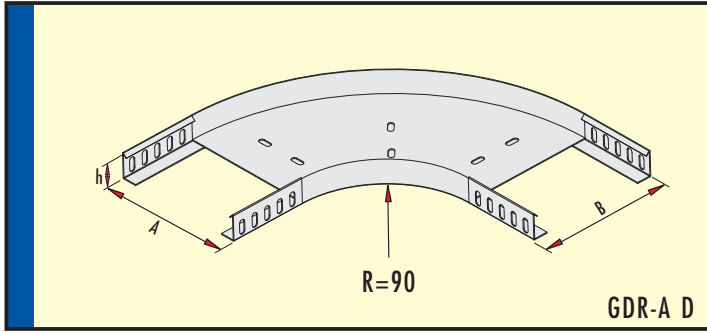

Bağlantı elemanları isteğe bağlı olarak 150-300-450-600-900 Radüslü imal edilir.

Circles can be produced with 150-300-450-600-900 Radius.

Соединительные элементы по заказу можно изготовить радиусом 150-300-450-600-900

#### 90° Dönüş Elemanı 90° Flat Bend

угловые элементы 90°

Sipariş kodu Order code Код заявки	Ağırlık (Kg/ad.) Weight (Kg/unit) Вес (кг / шт)	A-B mm	h mm	e mm	Price list прайс-лист шт / у.е.	
					Pre-Galvanized Предв. Цинк-ия	Hot dip Galvanized гор.оцинк. HDZ
GDR-A5D	0,820	55	40	1,5		9,84
GDR-A10D	1,100	105	40	1,5		0,72
GDR-A20D	1,650	205	40	1,5		19,80
GDR-A30D	3,230	305	40	2		38,76
GDR-A40D	4,500	405	40	2		54,00
GDR-A50D	6,030	505	40	2		72,36
GDR-A60D	7,800	605	40	2		93,60

#### T Bağlantı Elemanı Tees "T"

«Т» образные соединительные элементы

Sipariş kodu Order code Код заявки	Ağırlık (Kg/ad.) Weight (Kg/unit) Вес (кг / шт)	A-B-C mm	h mm	e mm	Price list прайс-лист шт / у.е.	
					Pre-Galvanized Предв. Цинк-ия	Hot dip Galvanized гор.оцинк. HDZ
GTR-A5D	1,150	55	40	1,5		13,80
GTR-A10D	1,610	105	40	1,5		19,32
GTR-A20D	2,380	205	40	1,5		28,56
GTR-A30D	4,510	305	40	2		54,12
GTR-A40D	6,170	405	40	2		74,04
GTR-A50D	8,130	505	40	2		97,56
GTR-A60D	10,420	605	40	2		125,04

#### Dörtlü Bağlantı Elemanı Crossing Element

крестообразные соединительные элементы

Sipariş kodu Order code Код заявки	Ağırlık (Kg/ad.) Weight (Kg/unit) Вес (кг / шт)	A-B-C-D mm	h mm	e mm	Price list прайс-лист шт / у.е.	
					Pre-Galvanized Предв. Цинк-ия	Hot dip Galvanized гор.оцинк. HDZ
GDBR-A5D	1,200	55	40	1,5		14,40
GDBR-A10D	1,980	105	40	1,5		23,76
GDBR-A20D	2,770	205	40	1,5		33,24
GDBR-A30D	4,920	305	40	2		59,04
GDBR-A40D	6,600	405	40	2		79,20
GDBR-A50D	8,600	505	40	2		103,20
GDBR-A60D	10,920	605	40	2		131,04

#### İç Bükey Elemanı Inside Vertical Bend

Внутри и снаружи Вертикальных Изгибов

Sipariş kodu Order code Код заявки	Ağırlık (Kg/ad.) Weight (Kg/unit) Вес (кг / шт)	A mm	h mm	e mm	Price list прайс-лист шт / у.е.	
					Pre-Galvanized Предв. Цинк-ия	Hot dip Galvanized гор.оцинк. HDZ
GIBR-A5D	0,650	55	40	1,5		7,80
GIBR-A10D	0,980	105	40	1,5		11,76
GIBR-A20D	1,240	205	40	1,5		14,88
GIBR-A30D	1,990	305	40	2		23,88
GIBR-A40D	2,330	405	40	2		27,96
GIBR-A50D	2,660	505	40	2		31,92
GIBR-A60D	3,000	605	40	2		36,00

#### Dış Bükey Elemanı Outside Vertical Bend

Внутри и снаружи Вертикальных Изгибов

Sipariş kodu Order code Код заявки	Ağırlık (Kg/ad.) Weight (Kg/unit) Вес (кг / шт)	A mm	h mm	e mm	Price list прайс-лист шт / у.е.	
					Pre-Galvanized Предв. Цинк-ия	Hot dip Galvanized гор.оцинк. HDZ
GIBDR-A5D	0,590	55	40	1,5		7,08
GIBDR-A10D	0,860	105	40	1,5		10,32
GIBDR-A20D	1,030	205	40	1,5		12,36
GIBDR-A30D	1,610	305	40	2		19,32
GIBDR-A40D	1,840	405	40	2		22,08
GIBDR-A50D	2,070	505	40	2		24,84
GIBDR-A60D	2,030	605	40	2		24,36

AĞIR HİZMET TİP KABLO KANALLARI

Heavy Duty Cable Trays

Сверхмощные кабельные лотки

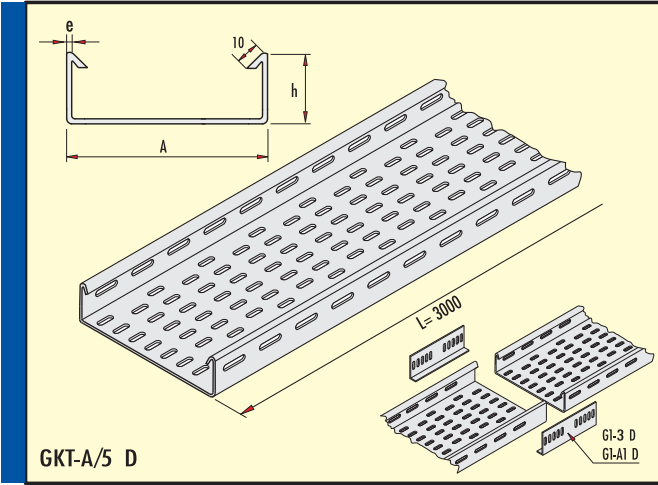

Ağır Hizmet Tipi Kablo Kanalı (h=50 mm)

Heavy Duty Cable Tray (h=50 mm) Сверхмощные кабельные лотки

Sipariş kodu Order code Код заявки	Ağırlık (Kg/mt.) Weight (Kg/mt) Вес (кг/м)	A mm	h mm	e mm	Price list прайс-лист М/у.е.	
					Pre-Galvanized Предв. Цинк-ия	Hot dip Galvanized гор.оцинк. HDZ
GKT-A5/5 D	1.240	50	50	1	6,20	11,16
GKT-A10-1/5 D	1.540	100	50	1	7,70	13,86
GKT-A10-2/5 D	2.310	100	50	1,5	11,55	20,79
GKT-A10-3/5 D	1.850	100	50	1,2	9,25	16,65
GKT-A20/5 D	3.520	200	50	1,5	17,60	31,68
GKT-A20-1/5 D	2.820	200	50	1,2	14,10	25,38
GKT-A30-1/5 D	4.400	300	50	1,5	22,00	39,60
GKT-A30-2/5 D	5.880	300	50	2	29,40	52,92
GKT-A40/5 D	7.120	400	50	2	35,60	64,08
GKT-A50/5 D	9.300	500	50	2	46,50	83,70
GKT-A60/5 D	10.340	600	50	2	51,70	93,06

DELİKSİZ AĞIR HİZMET KAPAKLI TİP KABLO KANALLARI

Неперфорированные Сверхмощные Кабельные Лотки С Крышкой

Non Perforated Heavy Duty Cable Trays With Cover

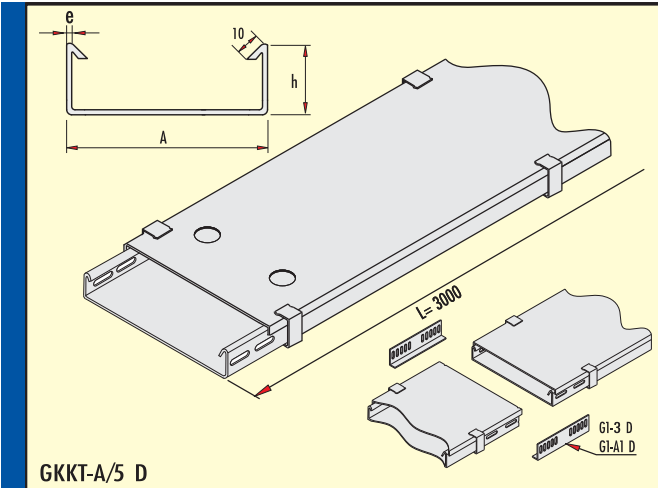

Deliksiz Ağır Hizmet Tipi Kablo Kanalı (h=50 mm)

Non Perforated Heavy Duty Cable Trays With Cover (h=50 mm)

Неперфорированные Сверхмощные Кабельные Лотки С Крышкой

Sipariş kodu Order code Код заявки	Ağırlık (Kg/mt.) Weight (Kg/mt) Вес (кг/м)	A mm	h mm	e mm	Price list прайс-лист М/у.е.	
					Pre-Galvanized Предв. Цинк-ия	Hot dip Galvanized гор.оцинк. HDZ
GKKT-A5/5 D	2,100	50	50	1	8,40	16,80
GKKT-A10-1/5 D	2,970	100	50	1	11,90	23,80
GKKT-A10-2/5 D	4,450	100	50	1,5	17,80	35,60
GKKT-A10-3/5 D	3,700	100	50	1,2	14,80	29,60
GKKT-A20/5 D	6,100	200	50	1,5	24,40	48,80
GKKT-A20-1/5 D	4,880	200	50	1,2	19,50	39,00
GKKT-A30-1/5 D	8,650	300	50	1,5	34,60	69,20
GKKT-A30-2/5 D	10,700	300	50	2	42,80	85,60
GKKT-A40/5 D	15,400	400	50	2	61,60	123,20
GKKT-A50/5 D	17,850	500	50	2	71,40	142,80
GKKT-A60/5 D	21,000	600	50	2	84,00	168,00

EK PARÇASI Jointing Piece

Соединительные элементы

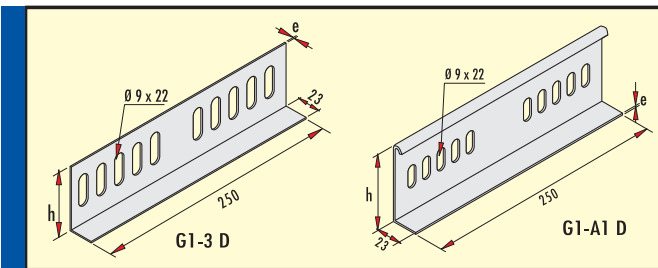

Ek Parçası (h=50 mm)  
Jointing Piece (h=50 mm)

Соединительные элементы

Sipariş kodu Order code Код заявки	Ağırlık (Kg/ad.) Weight (Kg/unit) Вес (кг/шт)	h mm	e mm	Price list прайс-лист ШТ/у.е.	
				Pre-Galvanized Предв. Цинк-ия	Hot dip Galvanized гор.оцинк. HDZ
G1 - 3 D	0,240	50	2	2,40	3,36
G1 - A1 D	0,300	54	2	3,00	4,20

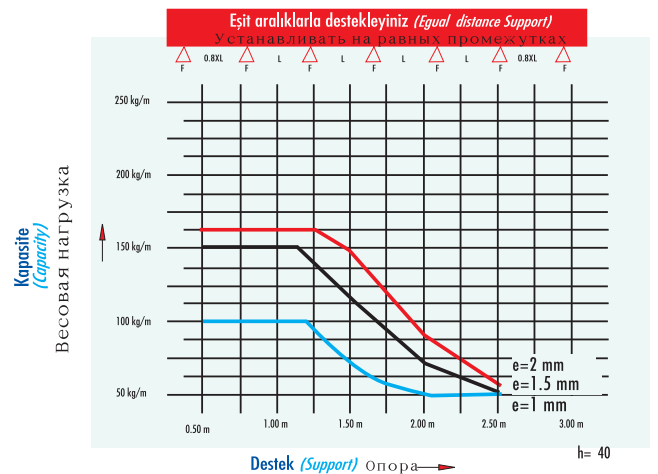

Kaplama : TS 914 EN ISO-1461 (BS-EN-ISO-1461) Sıcak Daldırma Galvaniz.  
Bu Ürünler İsteğe Bağlı Olarak Pregalvaniz ve CORTEN-A Sacdan İmal Edilebilir.

Coating : TS 914 EN ISO-1461 (BS-EN-ISO-1461) Hot Dip Galvanized

These products can be produced from Pregalvanized or CORTEN-A Steel according to the requirements.

Talep üzerine tüm ürünler RODINA 50® malzemesi ile kaplanarak (max) 400°C ısıya, asit, tuz ve kum etkilerine karşı mukavemet sağlar.

In case of required all type of materials can be coated with RODINA 50® which will give on extra resistant at effect of 400°C heat, acid, salt and sand for the material.

ĞİR HİZMET 90° DÖNÜŞ ELEMANLARI

90° Heavy Duty Flat Bends

Сверхмощные угловые элементы 90°

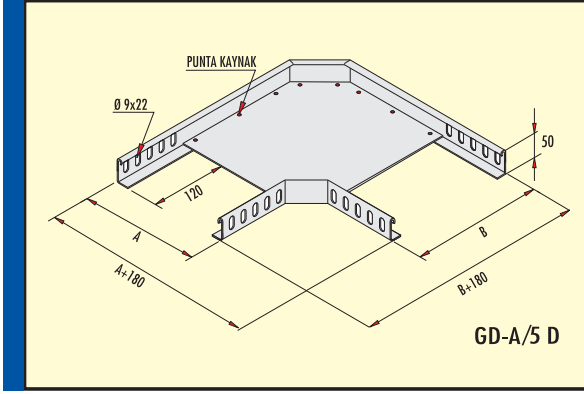

Ğır Hizmet 90° Dönüş Elemanı (h=50 mm)  
90° Heavy Duty Flat Bend (h=50 mm)

Сверхмощные угловые элементы 90°

Sipariş kodu Order code Код заявки	Ağırlık (Kg/ad.) Weight (Kg/unit) Вес (кг/шт)	A mm	B mm	e mm	Price list прайс-лист шт/у.е.	
					Pre-Galvanized Предв. Цинк-ия	Hot dip Galvanized гор.оцинк. HDZ
GD-A5/5 D	0,570	54	54	1	4,56	6,84
GD-A10/5 D	1,100	104	104	1,5	8,80	13,20
GD-A20/5 D	1,680	205	205	1,5	13,44	20,16
GD-A30/5 D	3,320	305	305	2	26,56	39,84
GD-A40/5 D	4,710	405	405	2	37,68	56,52
GD-A50/5 D	6,380	506	506	2	51,04	76,56
GD-A60/5 D	8,342	606	606	2	66,74	100,10

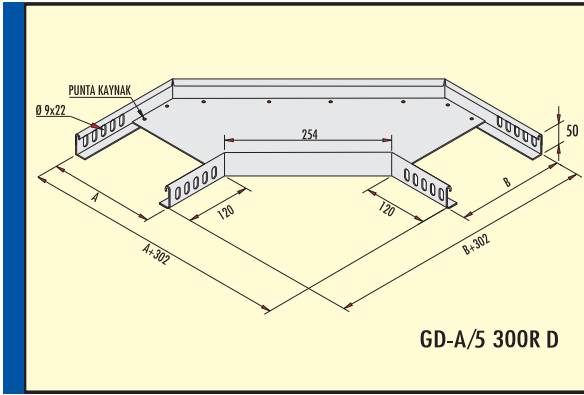

Ğır Hizmet 90° Dönüş Elemanı 300 Radüs (h=50 mm)  
90° Heavy Duty Flat Bend Radius 300 (h=50 mm)

Сверхмощные угловые элементы 90° (Радиус 300)

Sipariş kodu Order code Код заявки	Ağırlık (Kg/ad.) Weight (Kg/unit) Вес (кг/шт)	A mm	B mm	e mm	Price list прайс-лист шт/у.е.	
					Pre-Galvanized Предв. Цинк-ия	Hot dip Galvanized гор.оцинк. HDZ
GD-A5/5 300 R D	0,940	54	54	1	7,52	11,28
GD-A10/5 300 R D	1,650	104	104	1,5	13,20	19,80
GD-A20/5 300 R D	2,530	205	205	1,5	20,24	30,36
GD-A30/5 300 R D	4,850	305	305	2	38,80	58,20
GD-A40/5 300 R D	6,500	405	405	2	52,00	78,00
GD-A50/5 300 R D	8,650	506	506	2	69,20	103,80
GD-A60/5 300 R D	11,050	606	606	2	88,40	132,60

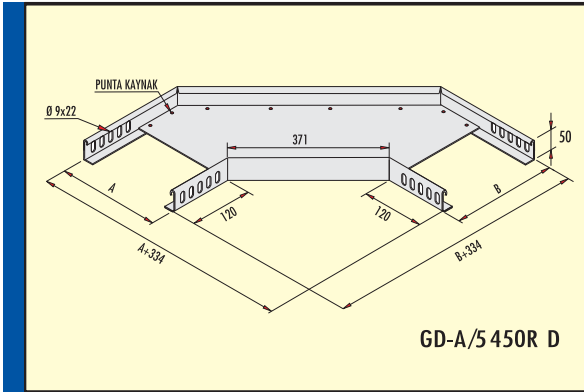

Ğır Hizmet 90° Dönüş Elemanı 450 Radüs (h=50 mm)  
90° Heavy Duty Flat Bend Radius 450 (h=50 mm)

Сверхмощные угловые элементы 90° Радиус 450

Sipariş kodu Order code Код заявки	Ağırlık (Kg/ad.) Weight (Kg/unit) Вес (кг/шт)	A mm	B mm	e mm	Price list прайс-лист шт/у.е.	
					Pre-Galvanized Предв. Цинк-ия	Hot dip Galvanized гор.оцинк. HDZ
GD-A5/5 450 R D	1,480	54	54	1	12,00	18,00
GD-A10/5 450 R D	2,920	104	104	1,5	23,00	35,00
GD-A20/5 450 R D	4,300	205	205	1,5	34,00	51,00
GD-A30/5 450 R D	5,400	305	305	2	43,00	64,00
GD-A40/5 450 R D	7,350	405	405	2	59,00	88,00
GD-A50/5 450 R D	9,450	506	506	2	75,00	113,00
GD-A60/5 450 R D	11,900	606	606	2	95,00	144,00

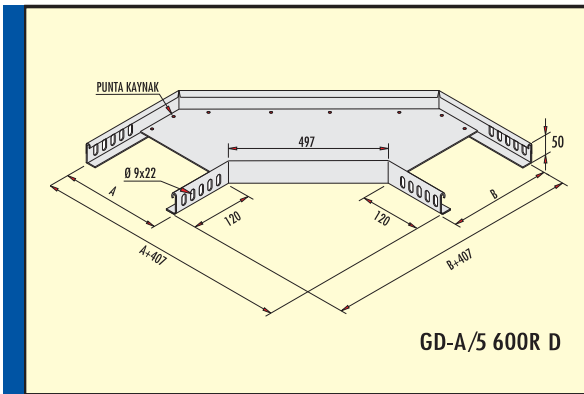

Ğır Hizmet 90° Dönüş Elemanı 600 Radüs (h=50 mm)  
90° Heavy Duty Flat Bend Radius 600 (h=50 mm)

Сверхмощные угловые элементы 90° (Радиус 600)

Sipariş kodu Order code Код заявки	Ağırlık (Kg/ad.) Weight (Kg/unit) Вес (кг/шт)	A mm	B mm	e mm	Price list прайс-лист шт/у.е.	
					Pre-Galvanized Предв. Цинк-ия	Hot dip Galvanized гор.оцинк. HDZ
GD-A5/5 600 R D	2,420	54	54	1	19,00	29,00
GD-A10/5 600 R D	3,450	104	104	1,5	27,00	41,00
GD-A20/5 600 R D	5,300	205	205	1,5	42,00	63,00
GD-A30/5 600 R D	6,800	305	305	2	54,00	81,00
GD-A40/5 600 R D	9,020	405	405	2	72,00	108,00
GD-A50/5 600 R D	10,650	506	506	2	85,00	128,00
GD-A60/5 600 R D	12,000	606	606	2	96,00	144,00

Kaplama : TS 914 EN ISO-1461 (BS-EN-ISO-1461) Sıcak Daldırma Galvaniz.  
Bu Ürünler İsteğe Bağlı Olarak Pregalvaniz ve CORTEN-A Saçdan İmal Edilebilir.

Coating : TS 914 EN ISO-1461 (BS-EN-ISO-1461) Hot Dip Galvanized  
These products can be produced from Pregalvanized or CORTEN-A Steel according to the requirements.

Talep üzerine tüm ürünler RODINA 50® malzemesi ile kaplanarak (max) 400°C ısıya, asit, tuz ve kum etkilerine karşı mukavemet sağlar.

In case of required all type of materials can be coated with RODINA 50® which will give on extra resistant at effect of 400°C heat, acid, salt and sand for the material.



## AĞIR HİZMET T BAĞLANTI ELEMANLARI

## Heavy Duty Tees "T"

Сверхмощные «Т» образные соединительные элементы

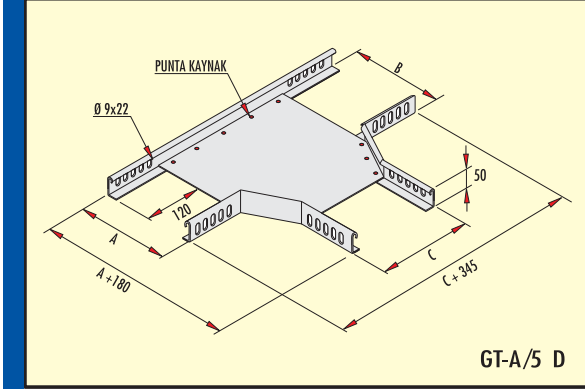

### Ağır Hizmet T Bağlantı Elemanı (h=50 mm) Heavy Duty Tees "T" (h=50 mm)

Сверхмощные «Т» образные соединительные элементы

Sipariş kodu Order code Код заявки	Ağırlık (Kg/ad.) Weight (Kg/unit) Вес (кг/шт)	A mm	B mm	C mm	e mm	Price list прайс-лист шт/у.е.	
						Pre-Galvanized Предв. Цинк-ия	Hot dip Galvanized гор.оцинк. HDZ
GT-A5/5 D	0,710	54	54	54	1	5,70	8,50
GT-A10/5 D	1,360	104	104	104	1,5	11,00	16,30
GT-A20/5 D	1,950	205	205	205	1,5	15,60	23,40
GT-A30/5 D	3,780	305	305	305	2	30,00	45,30
GT-A40/5 D	5,350	405	405	405	2	43,00	64,00
GT-A50/5 D	7,150	506	506	506	2	57,00	85,80
GT-A60/5 D	9,350	606	606	606	2	75,00	112,00

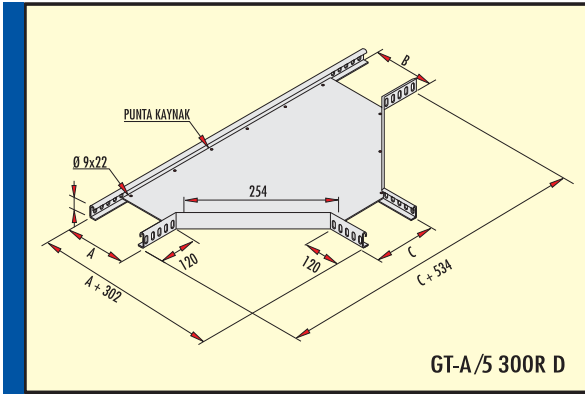

### Ağır Hizmet T Bağlantı Elemanı 300 Radüs (h=50 mm) Heavy Duty Tees "T" Radius 300 (h=50 mm)

Сверхмощные «Т» образные соединительные элементы (Радиус 300)

Sipariş kodu Order code Код заявки	Ağırlık (Kg/ad.) Weight (Kg/unit) Вес (кг/шт)	A mm	B mm	C mm	e mm	Price list прайс-лист шт/у.е.	
						Pre-Galvanized Предв. Цинк-ия	Hot dip Galvanized гор.оцинк. HDZ
GT-A5/5 300 R D	1,620	54	54	54	1	13,00	19,00
GT-A10/5 300 R D	2,800	104	104	104	1,5	22,00	33,00
GT-A20/5 300 R D	4,200	205	205	205	1,5	33,00	50,00
GT-A30/5 300 R D	7,560	305	305	305	2	60,00	91,00
GT-A40/5 300 R D	9,980	405	405	405	2	80,00	120,00
GT-A50/5 300 R D	12,450	506	506	506	2	99,00	149,00
GT-A60/5 300 R D	15,450	606	606	606	2	123,00	185,00

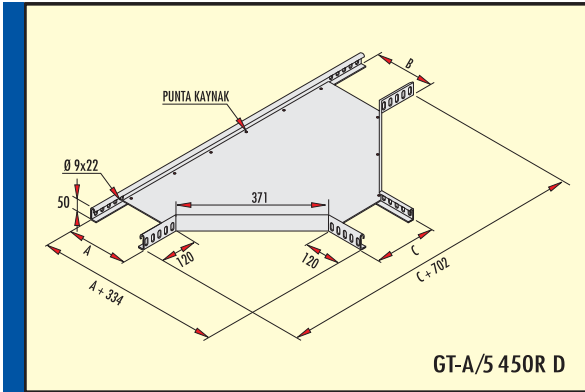

### Ağır Hizmet T Bağlantı Elemanı 450 Radüs (h=50 mm) Heavy Duty Tees "T" Radius 450 (h=50 mm)

Сверхмощные «Т» образные соединительные элементы (Радиус 450)

Sipariş kodu Order code Код заявки	Ağırlık (Kg/ad.) Weight (Kg/unit) Вес (кг/шт)	A mm	B mm	C mm	e mm	Price list прайс-лист шт/у.е.	
						Pre-Galvanized Предв. Цинк-ия	Hot dip Galvanized гор.оцинк. HDZ
GT-A5/5 450 R D	2,850	54	54	54	1	23,00	34,00
GT-A10/5 450 R D	3,780	104	104	104	1,5	30,00	45,00
GT-A20/5 450 R D	6,150	205	205	205	1,5	49,00	74,00
GT-A30/5 450 R D	10,800	305	305	305	2	86,00	129,00
GT-A40/5 450 R D	13,800	405	405	405	2	110,00	165,00
GT-A50/5 450 R D	15,900	506	506	506	2	127,00	190,00
GT-A60/5 450 R D	19,300	606	606	606	2	154,00	231,00

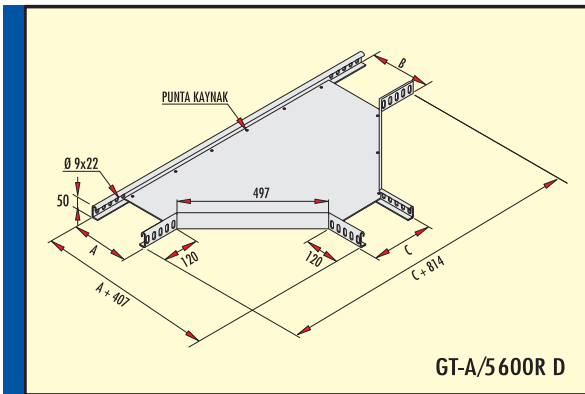

### Ağır Hizmet T Bağlantı Elemanı 600 Radüs (h=50 mm) Heavy Duty Tees "T" Radius 600 (h=50 mm)

Сверхмощные «Т» образные соединительные элементы (Радиус 600)

Sipariş kodu Order code Код заявки	Ağırlık (Kg/ad.) Weight (Kg/unit) Вес (кг/шт)	A mm	B mm	C mm	e mm	Price list прайс-лист шт/у.е.	
						Pre-Galvanized Предв. Цинк-ия	Hot dip Galvanized гор.оцинк. HDZ
GT-A5/5 600 R D	4,600	54	54	54	1	37,00	55,00
GT-A10/5 600 R D	5,500	104	104	104	1,5	44,00	66,00
GT-A20/5 600 R D	8,150	205	205	205	1,5	65,00	97,00
GT-A30/5 600 R D	13,900	305	305	305	2	111,00	167,00
GT-A40/5 600 R D	17,400	405	405	405	2	139,00	209,00
GT-A50/5 600 R D	19,700	506	506	506	2	157,00	236,00
GT-A60/5 600 R D	23,700	606	606	606	2	189,00	284,00

Kaplama : TS 914 EN ISO-1461 (BS-EN-ISO-1461) Sıcak Daldırma Galvaniz.  
Bu Ürünler İsteğe Bağlı Olarak Pregalvaniz ve CORTEN-A Sacdan İmal Edilebilir.

Coating : TS 914 EN ISO-1461 (BS-EN-ISO-1461) Hot Dip Galvanized  
These products can be produced from Pregalvanized or CORTEN-A Steel according to the requirements.

Talep üzerine tüm ürünler RODINA 50® malzemesi ile kaplanarak (max) 400°C ısıya, asit, tuz ve kum etkilerine karşı mukavemet sağlar.

In case of required all type of materials can be coated with RODINA 50® which will give on extra resistant at effect of 400°C heat, acid, salt and sand for the material.

## AĞIR HİZMET DÖRTLÜ BAĞLANTI ELEMANI *Heavy Duty Crossing*

Сверхмощные крестообразные соединительные элементы

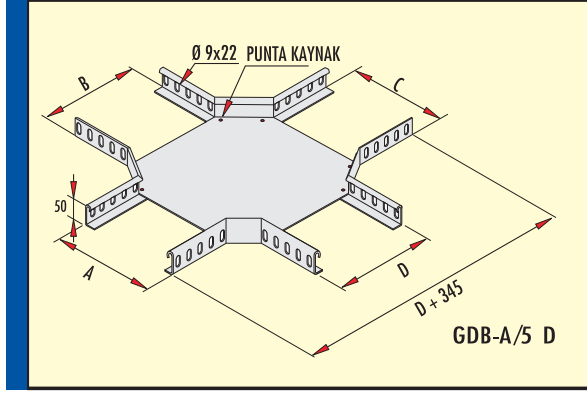

### Ağır Hizmet Dörtlü Bağlantı Elemanı (h=50 mm) *Heavy Duty Crossing (h=50 mm)*

Сверхмощные крестообразные соединительные элементы

Sipariş kodu Order code Код заявки	Ağırlık (Kg/ad.) Weight (Kg/unit) Вес (кг/шт)	A mm	B mm	C mm	D mm	e mm	Price list прайс-лист шт./у.е.	
							Pre-Galvanized Предв. Цинк-ия	Hot dip Galvanized гор.оцинк. HDZ
GDB-A5/5 D	0,900	54	54	54	54	1	7,20	11,00
GDB-A10/5 D	1,500	104	104	104	104	1,5	12,00	18,00
GDB-A20/5 D	2,300	205	205	205	205	1,5	18,40	27,00
GDB-A30/5 D	4,350	305	305	305	305	2	34,80	52,00
GDB-A40/5 D	6,950	405	405	405	405	2	55,60	83,00
GDB-A50/5 D	7,850	506	506	506	506	2	62,80	94,00
GDB-A60/5 D	10,100	606	606	606	606	2	80,00	120,00

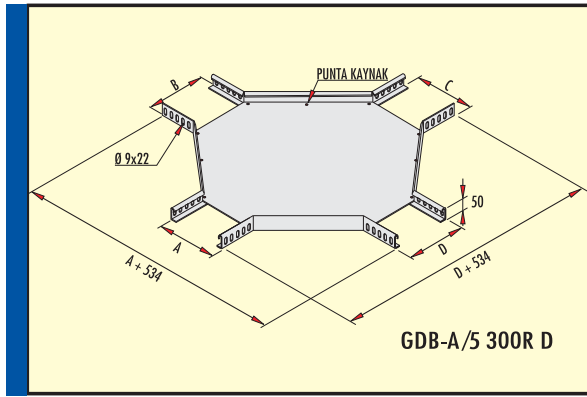

### Ağır Hizmet Dörtlü Bağlantı Elemanı 300 Radüs (h=50 mm) *Heavy Duty Crossing Radius 300 (h=50 mm)*

Сверхмощные крестообразные соединительные элементы (Радиус 300)

Sipariş kodu Order code Код заявки	Ağırlık (Kg/ad.) Weight (Kg/unit) Вес (кг/шт)	A mm	B mm	C mm	D mm	e mm	Price list прайс-лист шт./у.е.	
							Pre-Galvanized Предв. Цинк-ия	Hot dip Galvanized гор.оцинк. HDZ
GDB-A5/5 300R D	1,900	54	54	54	54	1	15,00	23,00
GDB-A10/5 300R D	3,400	104	104	104	104	1,5	27,00	41,00
GDB-A20/5 300R D	5,100	205	205	205	205	1,5	41,00	61,00
GDB-A30/5 300R D	8,900	305	305	305	305	2	71,00	106,00
GDB-A40/5 300R D	11,450	405	405	405	405	2	92,00	137,00
GDB-A50/5 300R D	14,200	506	506	506	506	2	113,00	170,00
GDB-A60/5 300R D	17,550	606	606	606	606	2	140,00	210,00

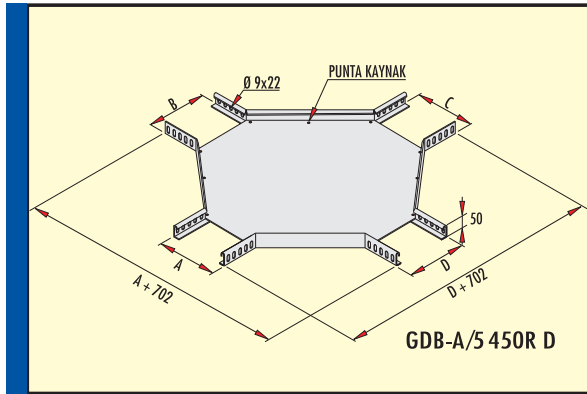

### Ağır Hizmet Dörtlü Bağlantı Elemanı 450 Radüs (h=50 mm) *Heavy Duty Crossing Radius 450 (h=50 mm)*

Сверхмощные крестообразные соединительные элементы (Радиус 450)

Sipariş kodu Order code Код заявки	Ağırlık (Kg/ad.) Weight (Kg/unit) Вес (кг/шт)	A mm	B mm	C mm	D mm	e mm	Price list прайс-лист шт./у.е.	
							Pre-Galvanized Предв. Цинк-ия	Hot dip Galvanized гор.оцинк. HDZ
GDB-A5/5 450R D	4,450	54	54	54	54	1	36,00	53,00
GDB-A10/5 450R D	5,150	104	104	104	104	1,5	41,00	62,00
GDB-A20/5 450R D	7,500	205	205	205	205	1,5	60,00	90,00
GDB-A30/5 450R D	12,700	305	305	305	305	2	101,00	165,00
GDB-A40/5 450R D	16,100	405	405	405	405	2	129,00	193,00
GDB-A50/5 450R D	19,450	506	506	506	506	2	155,00	233,00
GDB-A60/5 450R D	23,450	606	606	606	606	2	187,00	281,00

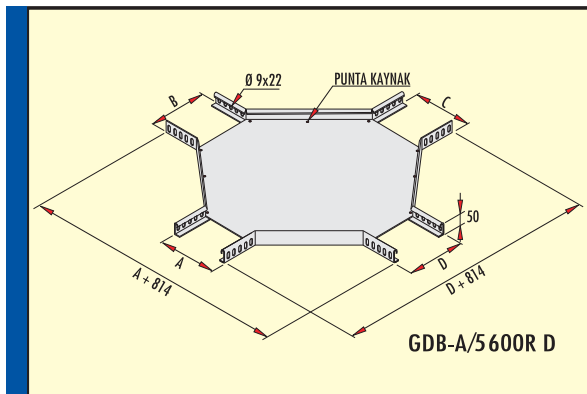

### Ağır Hizmet Dörtlü Bağlantı Elemanı 600 Radüs (h=50 mm) *Heavy Duty Crossing Radius 600 (h=50 mm)*

Сверхмощные крестообразные соединительные элементы (Радиус 600)

Sipariş kodu Order code Код заявки	Ağırlık (Kg/ad.) Weight (Kg/unit) Вес (кг/шт)	A mm	B mm	C mm	D mm	e mm	Price list прайс-лист шт./у.е.	
							Pre-Galvanized Предв. Цинк-ия	Hot dip Galvanized гор.оцинк. HDZ
GDB-A5/5 600R D	6,000	54	54	54	54	1	48,00	72,00
GDB-A10/5 600R D	6,850	104	104	104	104	1,5	55,00	82,00
GDB-A20/5 600R D	9,600	205	205	205	205	1,5	77,00	115,00
GDB-A30/5 600R D	16,000	305	305	305	305	2	128,00	192,00
GDB-A40/5 600R D	19,750	405	405	405	405	2	160,00	230,00
GDB-A50/5 600R D	23,750	506	506	506	506	2	190,00	284,00
GDB-A60/5 600R D	28,200	606	606	606	606	2	224,00	336,00

Kaplama : TS 914 EN ISO-1461 (BS-EN-ISO-1461) Sıcak Daldırma Galvaniz.  
Bu Ürünler İsteğe Bağlı Olarak Pregalvaniz ve CORTEN-A Sacdan İmal Edilebilir.

Coating : TS 914 EN ISO-1461 (BS-EN-ISO-1461) Hot Dip Galvanized  
These products can be produced from Pregalvanized or CORTEN-A Steel according to the requirements.

Talep üzerine tüm ürünler RODINO 50® malzemesi ile kaplanarak (max) 400°C ısıya, asit, tuz ve kum etkilerine karşı mukavemet sağlar.  
In case of required all type of materials can be coated with RODINO 50® which will give on extra resistant at effect of 400°C heat, acid, salt and sand for the material.

135° AĞIR HİZMET DÖNÜŞ ELEMANI 135° Heavy Duty Flat Bend

Плоский Изгиб и Покрытие 135°

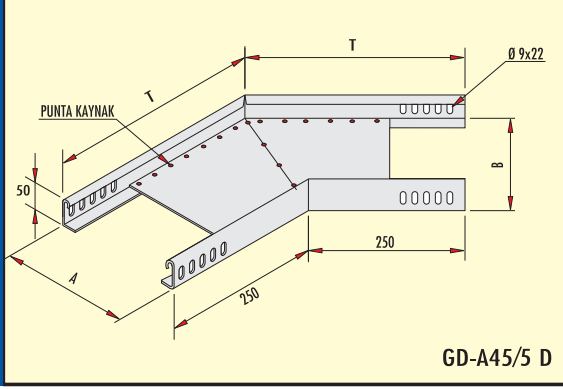

135° Ağır Hizmet Dönüş Elemanı (h=50 mm)  
135° Heavy Duty Flat Bend (h=50 mm)  
Плоский Изгиб 135°

Sipariş kodu Order code Код заявки	Ağırlık (Kg/ad.) Weight (Kg/unit) Вес (кг/шт)	A mm	B mm	T mm	e mm	Price list прайс-лист шт/у.е.	
						Pre-Galvanized Предв. Цинк-ия	Hot dip Galvanized гор.оцинк. HDZ
GD-A5-45/5 D	0,470	54	54	271	1,5	3,76	5,60
GD-A10-45/5 D	0,950	104	104	291	1,5	7,60	11,40
GD-A20-45/5 D	1,900	205	205	333	1,5	15,20	22,80
GD-A30-45/5 D	3,200	305	305	374	2	25,60	38,40
GD-A40-45/5 D	4,300	405	405	416	2	34,40	51,60
GD-A50-45/5 D	5,600	506	506	457	2	44,80	67,20
GD-A60-45/5 D	6,850	606	606	499	2	54,80	82,00

AĞIR HİZMET İÇ-DIŞ BÜKEY ELEMANI

Heavy Duty Inside and Outside Vertical Bend

Внутри и снаружи Вертикального Изгиба и Покрытий

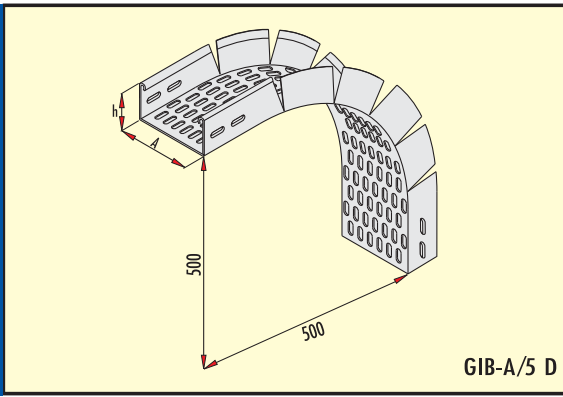

Ağır Hizmet İç-Dış Bükey Elemanı (h=50 mm)  
Heavy Duty Inside and Outside Vertical Bend (h=50 mm)  
Внутри и снаружи Вертикальных Изгибов

Sipariş kodu Order code Код заявки	Ağırlık (Kg/ad.) Weight (Kg/unit) Вес (кг/шт)	A mm	h mm	e mm	Price list прайс-лист шт/у.е.	
					Pre-Galvanized Предв. Цинк-ия	Hot dip Galvanized гор.оцинк. HDZ
GIB-A5/5 D	1,650	50	50	1,5	13,20	19,80
GIB-A10/5 D	2,150	100	50	1,5	17,20	25,80
GIB-A20/5 D	3,050	200	50	1,5	24,40	36,60
GIB-A30/5 D	5,300	300	50	2	42,40	63,60
GIB-A40/5 D	6,350	400	50	2	50,80	76,20
GIB-A50/5 D	7,650	500	50	2	61,20	91,80
GIB-A60/5 D	9,100	600	50	2	72,80	109,20

DIKEY "T"

Vertical "Tee"

Вертикальная "Мишень"

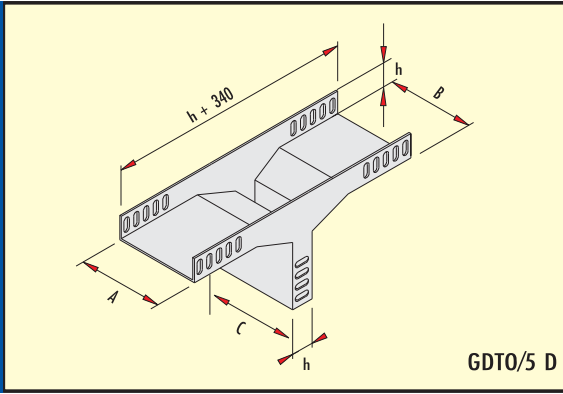

Dikey "T" Ortadan (h=50 mm)  
Vertical "Tee" Center (h=50 mm)  
Вертикальная "Мишень"

Sipariş kodu Order code Код заявки	Ağırlık (Kg/ad.) Weight (Kg/unit) Вес (кг/шт)	A-B-C mm	h mm	e mm	Price list прайс-лист шт/у.е.	
					Pre-Galvanized Предв. Цинк-ия	Hot dip Galvanized гор.оцинк. HDZ
GDTO-5/5 D	1,160	50	50	1,5	11,60	16,25
GDTO-10/5 D	1,550	100	50	1,5	15,50	22,00
GDTO-20/5 D	2,400	200	50	1,5	24,00	34,00
GDTO-30/5 D	3,250	300	50	2	32,50	45,00
GDTO-40/5 D	5,500	400	50	2	55,00	75,00
GDTO-50/5 D	6,650	500	50	2	66,50	91,00
GDTO-60/5 D	7,800	600	50	2	78,00	106,00

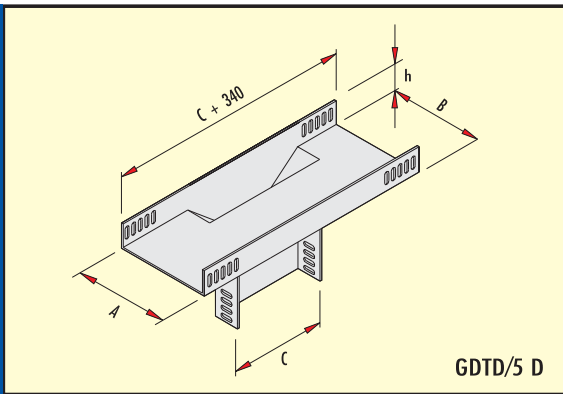

Dikey "T" Duvarдан (h=50 mm)  
Vertical "Tee" Wall (h=50 mm)  
Вертикальная "Мишень"

Sipariş kodu Order code Код заявки	Ağırlık (Kg/ad.) Weight (Kg/unit) Вес (кг/шт)	A-B-C mm	h mm	e mm	Price list прайс-лист шт/у.е.	
					Pre-Galvanized Предв. Цинк-ия	Hot dip Galvanized гор.оцинк. HDZ
GDTD-5/5 D	1,200	50	50	1,5	12,00	16,80
GDTD-10/5 D	1,650	100	50	1,5	16,50	23,10
GDTD-20/5 D	2,800	200	50	1,5	28,00	39,00
GDTD-30/5 D	4,300	300	50	2	43,00	60,00
GDTD-40/5 D	8,150	400	50	2	81,50	114,00
GDTD-50/5 D	10,900	500	50	2	109,00	152,00
GDTD-60/5 D	14,000	600	50	2	140,00	196,00

Kaplama : TS 914 EN ISO-1461 (BS-EN-ISO-1461) Sıcak Daldırma Galvaniz.  
Bu Ürünler İsteğe Bağlı Olarak Pregalvaniz ve CORTEN-A Sacdan İmal Edilebilir.

Coating : TS 914 EN ISO-1461 (BS-EN-ISO-1461) Hot Dip Galvanized  
These products can be produced from Pregalvanized or CORTEN-A Steel according to the requirements.

Talep üzerine tüm ürünler RODINA 50® malzemesi ile kaplanarak (max) 400°C ısıya, asit, tuz ve kum etkilerine karşı mukavemet sağlar.

In case of required all type of materials can be coated with RODINA 50® which will give on extra resistant at effect of 400°C heat, acid, salt and sand for the material.



## RADÜSLÜ DÖNÜŞ ELEMANLARI

### Flat Bends

### Углы с Плавным Переходом

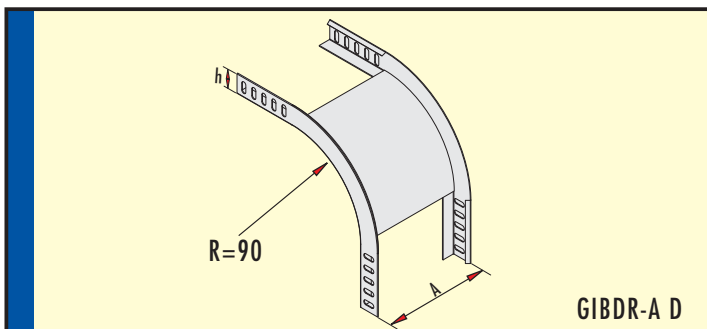
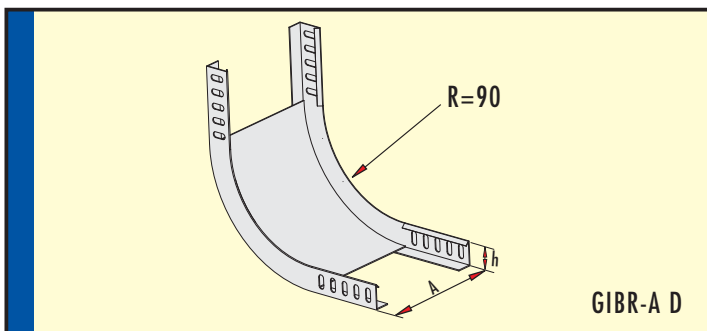
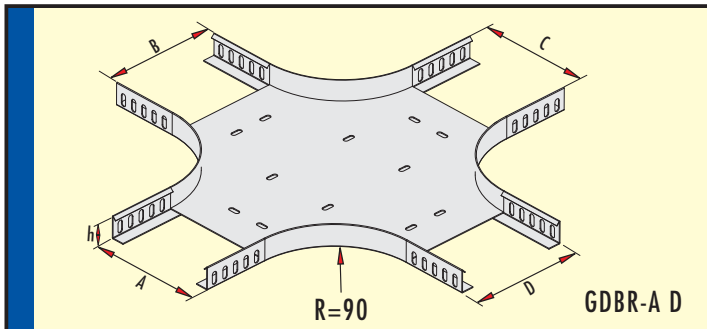
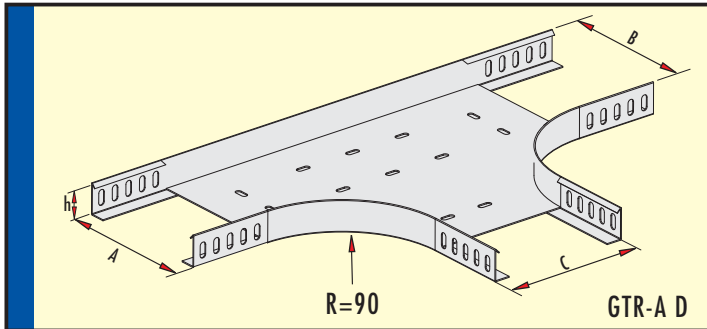
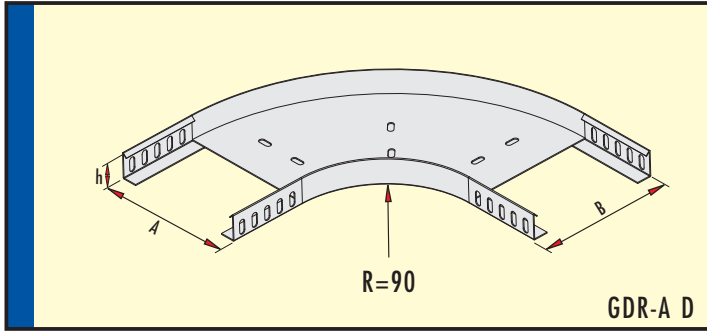

Bağlantı elemanları isteğe bağlı olarak 150-300-450-600-900 Radüslü imal edilir.

Circles can be produced with 150-300-450-600-900 Radius.

Соединительные элементы по заказу можно изготовить радиусом 150-300-450-600-900

#### 90° Dönüş Elemanı 90° Flat Bend

угловые элементы 90°

Sipariş kodu Order code Код заявки	Ağırlık (Kg/ad.) Weight (Kg/unit) Вес (кг / шт)	A-B mm	h mm	e mm	Price list прайс-лист шт./у.е.	
					Pre-Galvanized Предв. Цинк-ия	Hot dip Galvanized гор.оцинк. HDZ
GDR-A5D	0.950	55	50	1,5		9,84
GDR-A10D	1.170	105	50	1,5		12,00
GDR-A20D	1.780	205	50	1,5		21,00
GDR-A30D	3.420	305	50	2		40,00
GDR-A40D	4.720	405	50	2		57,00
GDR-A50D	6.270	505	50	2		75,00
GDR-A60D	8.070	605	50	2		98,00

#### T Bağlantı Elemanı Tees "T"

«Т» образные соединительные элементы

Sipariş kodu Order code Код заявки	Ağırlık (Kg/ad.) Weight (Kg/unit) Вес (кг / шт)	A-B-C mm	h mm	e mm	Price list прайс-лист шт./у.е.	
					Pre-Galvanized Предв. Цинк-ия	Hot dip Galvanized гор.оцинк. HDZ
GTR-A5D	1.350	55	50	1,5		15,00
GTR-A10D	1.760	105	50	1,5		21,00
GTR-A20D	2.540	205	50	1,5		30,00
GTR-A30D	4.750	305	50	2		57,00
GTR-A40D	6.420	405	50	2		78,00
GTR-A50D	8.400	505	50	2		101,00
GTR-A60D	10.700	605	50	2		130,00

#### Dörtlü Bağlantı Elemanı Crossing Element

крестообразные соединительные элементы

Sipariş kodu Order code Код заявки	Ağırlık (Kg/ad.) Weight (Kg/unit) Вес (кг / шт)	A-B-C-D mm	h mm	e mm	Price list прайс-лист шт./у.е.	
					Pre-Galvanized Предв. Цинк-ия	Hot dip Galvanized гор.оцинк. HDZ
GDBR-A5D	1.850	55	50	1,5		16,00
GDBR-A10D	2.160	105	50	1,5		26,00
GDBR-A20D	2.950	205	50	1,5		35,00
GDBR-A30D	5.160	305	50	2		62,00
GDBR-A40D	6.840	405	50	2		83,00
GDBR-A50D	8.840	505	50	2		107,00
GDBR-A60D	11.160	605	50	2		135,00

#### İç Bükey Elemanı Inside Vertical Bend

Внутри и снаружи Вертикальных Изгибов

Sipariş kodu Order code Код заявки	Ağırlık (Kg/ad.) Weight (Kg/unit) Вес (кг / шт)	A mm	h mm	e mm	Price list прайс-лист шт./у.е.	
					Pre-Galvanized Предв. Цинк-ия	Hot dip Galvanized гор.оцинк. HDZ
GIBR-A5D	0.850	55	50	1,5		9,00
GIBR-A10D	1.120	105	50	1,5		13,00
GIBR-A20D	1.400	205	50	1,5		16,00
GIBR-A30D	2.220	305	50	2		26,00
GIBR-A40D	2.580	405	50	2		31,00
GIBR-A50D	2.990	505	50	2		35,00
GIBR-A60D	3.310	605	50	2		40,00

#### Dış Bükey Elemanı Outside Vertical Bend

Внутри и снаружи Вертикальных Изгибов

Sipariş kodu Order code Код заявки	Ağırlık (Kg/ad.) Weight (Kg/unit) Вес (кг / шт)	A mm	h mm	e mm	Price list прайс-лист шт./у.е.	
					Pre-Galvanized Предв. Цинк-ия	Hot dip Galvanized гор.оцинк. HDZ
GIBDR-A5D	0.750	55	50	1,5		9,00
GIBDR-A10D	0.970	105	50	1,5		13,00
GIBDR-A20D	1.140	205	50	1,5		16,00
GIBDR-A30D	1.760	305	50	2		26,00
GIBDR-A40D	1.990	405	50	2		31,00
GIBDR-A50D	2.220	505	50	2		35,00
GIBDR-A60D	2.450	605	50	2		40,00

AĞIR HİZMET TİP KABLO KANALLARI

Heavy Duty Cable Trays

Сверхмощные кабельные лотки

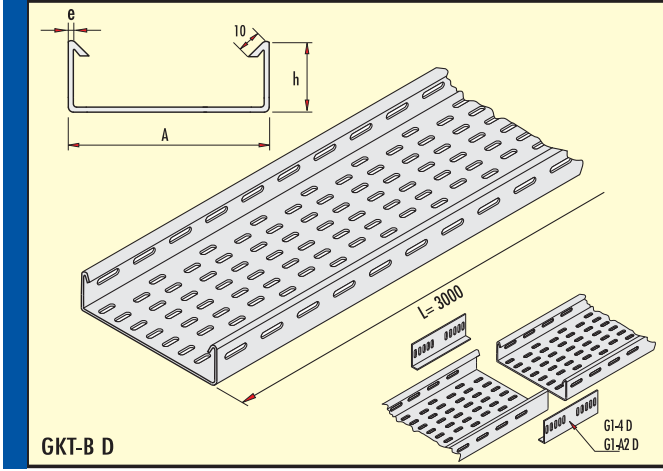

Ağır Hizmet Tipi Kablo Kanalı (h=60 mm)

Heavy Duty Cable Tray (h=60 mm)

Сверхмощные кабельные лотки

Sipariş kodu Order code Код заявки	Ağırlık (Kg/mt.) Weight (Kg/mt) Вес (кг/м)	A mm	h mm	e mm	Price list прайс-лист М/у.е.	
					Pre-Galvanized Предв. Цинк-ия	Hot dip Galvanized гор.оцинк. HDZ
GKT-B5 D	1,400	50	60	1	7,00	12,60
GKT-B10 D	2,600	100	60	1,5	13,00	23,40
GKT-B10-1 D	1,730	100	60	1	8,65	15,57
GKT-B20 D	3,750	200	60	1,5	18,75	33,75
GKT-B30-1 D	4,650	300	60	1,5	23,25	41,85
GKT-B30-2 D	6,200	300	60	2	31,00	55,80
GKT-B40 D	7,500	400	60	2	37,50	67,50
GKT-B50 D	9,200	500	60	2	46,00	82,80
GKT-B60 D	10,600	600	60	2	53,00	95,40

DELİKSİZ AĞIR HİZMET KAPAKLI TİP KABLO KANALLARI

Сверхмощные кабельные лотки с крышкой

Non Perforated Heavy Duty Cable Trays With Cover

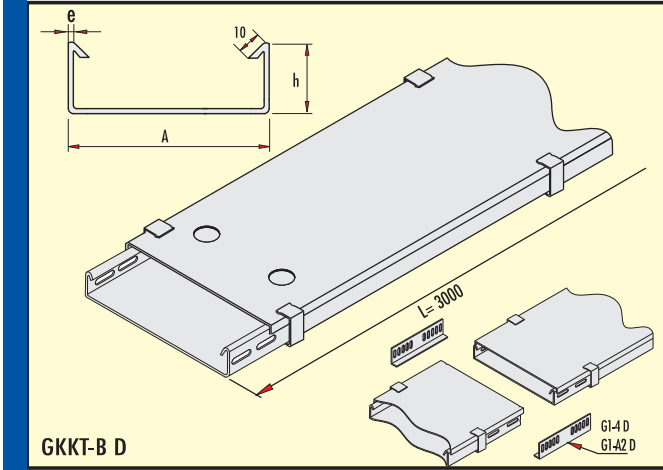

Deliksiz Ağır Hizmet Tipi Kablo Kanalı (h=60 mm)

Non Perforated Heavy Duty Cable Trays With Cover (h=60 mm)

Сверхмощные кабельные лотки с крышкой

Sipariş kodu Order code Код заявки	Ağırlık (Kg/mt.) Weight (Kg/mt) Вес (кг/м)	A mm	h mm	e mm	Price list прайс-лист М/у.е.	
					Pre-Galvanized Предв. Цинк-ия	Hot dip Galvanized гор.оцинк. HDZ
GKKT-B5 D	2,100	50	60	1	8,40	16,80
GKKT-B10 D	4,150	100	60	1,5	16,60	33,20
GKKT-B10-1 D	2,800	100	60	1	11,20	22,40
GKKT-B20 D	5,650	200	60	1,5	22,60	45,20
GKKT-B30-1 D	8,400	300	60	1,5	33,60	67,20
GKKT-B30-2 D	10,400	300	60	2	41,60	83,20
GKKT-B40 D	14,700	400	60	2	58,80	117,60
GKKT-B50 D	17,700	500	60	2	70,80	141,60
GKKT-B60 D	20,700	600	60	2	82,80	165,60

EK PARÇASI Jointing Piece

Соединительные элементы

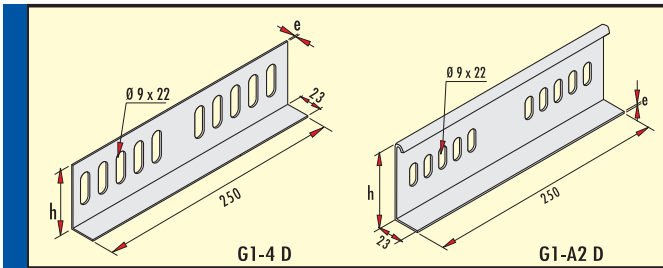

Ek Parçası (h=60 mm)  
Jointing Piece (h=60 mm)

Соединительные элементы

Sipariş kodu Order code Код заявки	Ağırlık (Kg/ad.) Weight (Kg/unit) Вес (кг/шт)	h mm	e mm	Price list прайс-лист шт/у.е.	
				Pre-Galvanized Предв. Цинк-ия	Hot dip Galvanized гор.оцинк. HDZ
G1 - 4 D	0,270	60	2	2,70	3,80
G1 - A2 D	0,330	64	2	3,30	4,60

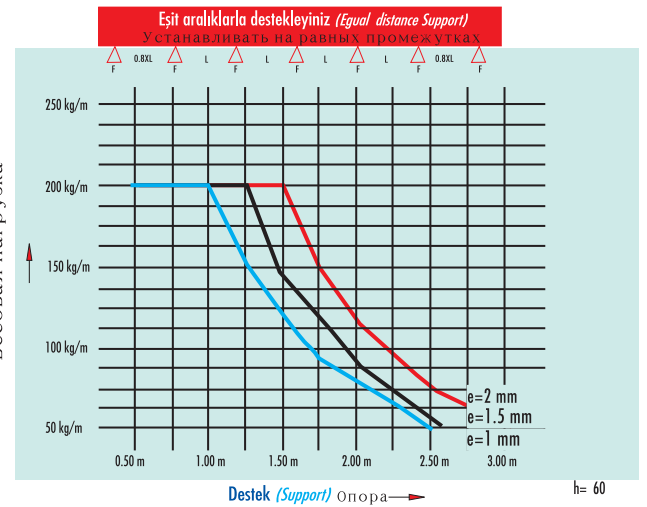

Kaplama : TS 914 EN ISO-1461 (BS-EN-ISO-1461) Sıcak Daldırma Galvaniz.  
Bu Ürünler İsteğe Bağlı Olarak Pregalvaniz ve CORTEN-A Saçdan İmal Edilebilir.

Coating : TS 914 EN ISO-1461 (BS-EN-ISO-1461) Hot Dip Galvanized

These products can be produced from Pregalvanized or CORTEN-A Steel according to the requirements.

Talep üzerine tüm ürünler RODINO 50® malzemesi ile kaplanarak (max) 400°C ısıya, asit, tuz ve kum etkilerine karşı mukavemet sağlar.

In case of required all type of materials can be coated with RODINO 50® which will give on extra resistant at effect of 400°C heat, acid, salt and sand for the material.

AGIR HİZMET 90° DÖNÜŞ ELEMANLARI

90° Heavy Duty Flat Bends

Сверхмощные угловые элементы 90°

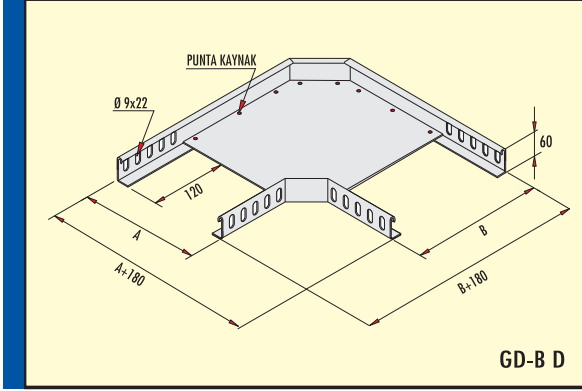

Ağır Hizmet 90° Dönüş Elemanı (h=60 mm)  
90° Heavy Duty Flat Bend (h=60 mm)  
Сверхмощные угловые элементы 90°

Sipariş kodu Order code Код заявки	Ağırlık (Kg/ad.) Weight (Kg/unit) Вес (кг/шт)	A mm	B mm	e mm	Price list прайс-лист шт/у.е.	
					Pre-Galvanized Предв. Цинк-ия	Hot dip Galvanized гор.оцинк. HDZ
GD-B5 D	0,631	54	54	1	5,05	7,50
GD-B10 D	1,184	104	104	1,5	9,47	14,20
GD-B20 D	1,810	205	205	1,5	14,48	21,70
GD-B30 D	3,524	305	305	2	28,19	42,30
GD-B40 D	5,000	405	405	2	40,00	60,00
GD-B50 D	6,650	506	506	2	53,20	78,00
GD-B60 D	8,624	606	606	2	68,99	103,50

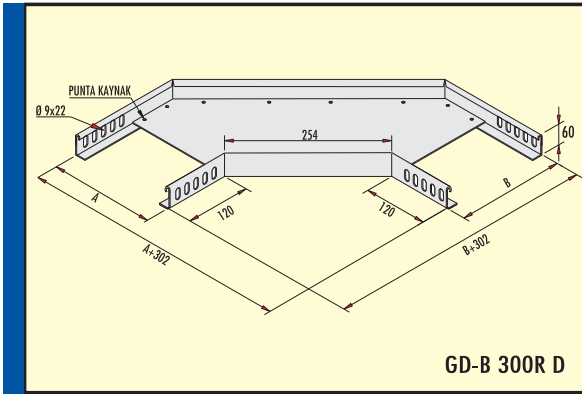

Ağır Hizmet 90° Dönüş Elemanı 300 Radyüs (h=60 mm)  
90° Heavy Duty Flat Bend Radius 300 (h=60 mm)  
Сверхмощные угловые элементы 90° (Радиус 300)

Sipariş kodu Order code Код заявки	Ağırlık (Kg/ad.) Weight (Kg/unit) Вес (кг/шт)	A mm	B mm	e mm	Price list прайс-лист шт/у.е.	
					Pre-Galvanized Предв. Цинк-ия	Hot dip Galvanized гор.оцинк. HDZ
GD-B5 300R D	1,490	54	54	1	12,00	18,00
GD-B10 300R D	2,050	104	104	1,5	16,40	24,60
GD-B20 300R D	3,150	205	205	1,5	25,20	37,80
GD-B30 300R D	5,080	305	305	2	40,60	61,00
GD-B40 300R D	7,000	405	405	2	56,00	84,00
GD-B50 300R D	9,000	506	506	2	72,00	108,00
GD-B60 300R D	11,000	606	606	2	88,00	132,00

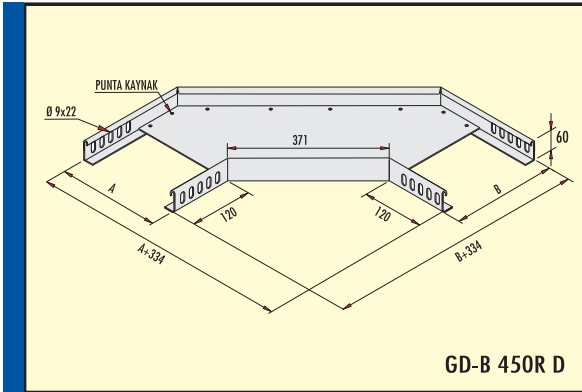

Ağır Hizmet 90° Dönüş Elemanı 450 Radyüs (h=60 mm)  
90° Heavy Duty Flat Bend Radius 450 (h=60 mm)  
Сверхмощные угловые элементы 90° Радиус 450

Sipariş kodu Order code Код заявки	Ağırlık (Kg/ad.) Weight (Kg/unit) Вес (кг/шт)	A mm	B mm	e mm	Price list прайс-лист шт/у.е.	
					Pre-Galvanized Предв. Цинк-ия	Hot dip Galvanized гор.оцинк. HDZ
GD-B5 450R D	2,600	54	54	1	20,80	31,20
GD-B10 450R D	3,150	104	104	1,5	25,20	37,80
GD-B20 450R D	4,000	205	205	1,5	32,00	48,00
GD-B30 450R D	5,700	305	305	2	45,60	68,40
GD-B40 450R D	7,300	405	405	2	58,40	87,60
GD-B50 450R D	9,200	506	506	2	73,60	110,40
GD-B60 450R D	11,500	606	606	2	92,00	138,00

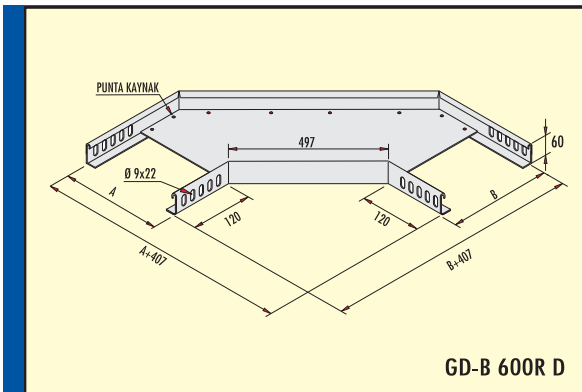

Ağır Hizmet 90° Dönüş Elemanı 600 Radyüs (h=60 mm)  
90° Heavy Duty Flat Bend Radius 600 (h=60 mm)  
Сверхмощные угловые элементы 90° (Радиус 600)

Sipariş kodu Order code Код заявки	Ağırlık (Kg/ad.) Weight (Kg/unit) Вес (кг/шт)	A mm	B mm	e mm	Price list прайс-лист шт/у.е.	
					Pre-Galvanized Предв. Цинк-ия	Hot dip Galvanized гор.оцинк. HDZ
GD-B5 600R D	3,100	54	54	1	24,80	37,20
GD-B10 600R D	3,750	104	104	1,5	30,00	45,00
GD-B20 600R D	5,100	205	205	1,5	40,80	61,20
GD-B30 600R D	6,500	305	305	2	52,00	78,00
GD-B40 600R D	8,400	405	405	2	67,20	100,80
GD-B50 600R D	10,600	506	506	2	84,80	127,20
GD-B60 600R D	13,100	606	606	2	104,80	157,20

Kaplama : TS 914 EN ISO-1461 (BS-EN-ISO-1461) Sıcak Daldırma Galvaniz.  
Bu Ürünler İsteğe Bağlı Olarak Pregalvaniz ve CORTEN-A Saçdan İmal Edilebilir.

Coating : TS 914 EN ISO-1461 (BS-EN-ISO-1461) Hot Dip Galvanized  
These products can be produced from Pregalvanized or CORTEN-A Steel according to the requirements.

Talep üzerine tüm ürünler RODINO 50® malzemesi ile kaplanarak (max) 400°C ısıya, asit, tuz ve kum etkilerine karşı mukavemet sağlar.

In case of required all type of materials can be coated with RODINO 50® which will give on extra resistant at effect of 400°C heat, acid, salt and sand for the material.



## AĞIR HİZMET T BAĞLANTI ELEMANLARI

## Heavy Duty Tees "T"

Сверхмощные «Т» образные соединительные элементы

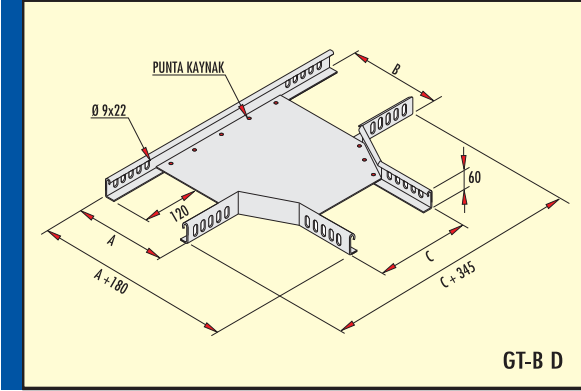

### Ağır Hizmet T Bağlantı Elemanı (h=60 mm)

#### Heavy Duty Tees "T" (h=60 mm)

Сверхмощные «Т» образные соединительные элементы

Sipariş kodu Order code Код заявки	Ağırlık (Kg/ad.) Weight (Kg/unit) Вес (кг / шт)	A mm	B mm	C mm	e mm	Price list прайс-лист шт / у.е.	
						Pre-Galvanized Предв. Цинк-ия	Hot dip Galvanized гор.оцинк. HDZ
GT-B5 D	1,200	54	54	54	1	9,60	14,40
GT-B10 D	1,500	104	104	104	1.5	12,00	18,00
GT-B20 D	2,100	205	205	205	1.5	16,80	25,20
GT-B30 D	4,250	305	305	305	2	34,00	51,00
GT-B40 D	5,450	405	405	405	2	43,60	65,40
GT-B50 D	7,250	506	506	506	2	58,00	87,00
GT-B60 D	10,850	606	606	606	2	86,80	130,20

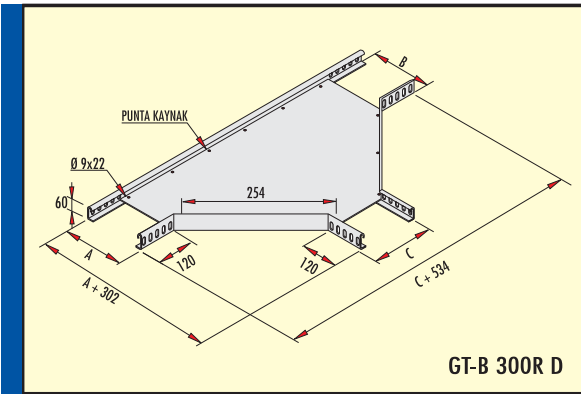

### Ağır Hizmet T Bağlantı Elemanı 300 Radius (h=60 mm)

#### Heavy Duty Tees "T" Radius 300 (h=60 mm)

Сверхмощные «Т» образные соединительные элементы (Радиус 300)

Sipariş kodu Order code Код заявки	Ağırlık (Kg/ad.) Weight (Kg/unit) Вес (кг / шт)	A mm	B mm	C mm	e mm	Price list прайс-лист шт / у.е.	
						Pre-Galvanized Предв. Цинк-ия	Hot dip Galvanized гор.оцинк. HDZ
GT-B5 300R D	2,250	54	54	54	1	18,00	27,00
GT-B10 300R D	3,000	104	104	104	1.5	24,00	36,00
GT-B20 300R D	4,450	205	205	205	1.5	35,60	53,40
GT-B30 300R D	7,800	305	305	305	2	62,40	93,60
GT-B40 300R D	10,200	405	405	405	2	81,60	122,40
GT-B50 300R D	12,500	506	506	506	2	100,00	150,00
GT-B60 300R D	15,500	606	606	606	2	124,00	186,00

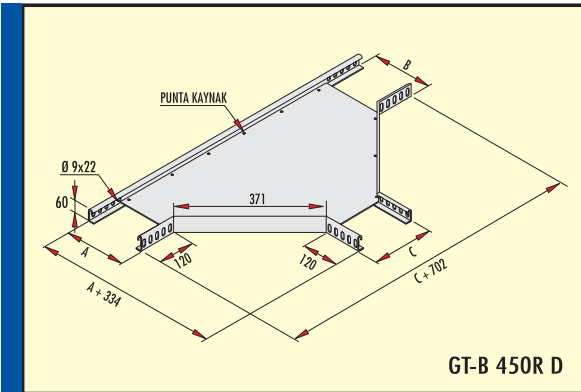

### Ağır Hizmet T Bağlantı Elemanı 450 Radius (h=60 mm)

#### Heavy Duty Tees "T" Radius 450 (h=60 mm)

Сверхмощные «Т» образные соединительные элементы (Радиус 450)

Sipariş kodu Order code Код заявки	Ağırlık (Kg/ad.) Weight (Kg/unit) Вес (кг / шт)	A mm	B mm	C mm	e mm	Price list прайс-лист шт / у.е.	
						Pre-Galvanized Предв. Цинк-ия	Hot dip Galvanized гор.оцинк. HDZ
GT-B5 450R D	2,900	54	54	54	1	23,20	34,80
GT-B10 450R D	4,050	104	104	104	1.5	32,40	48,60
GT-B20 450R D	6,350	205	205	205	1.5	50,80	76,20
GT-B30 450R D	11,100	305	305	305	2	88,80	133,20
GT-B40 450R D	13,800	405	405	405	2	110,40	165,60
GT-B50 450R D	16,000	506	506	506	2	128,00	192,00
GT-B60 450R D	19,250	606	606	606	2	154,00	231,00

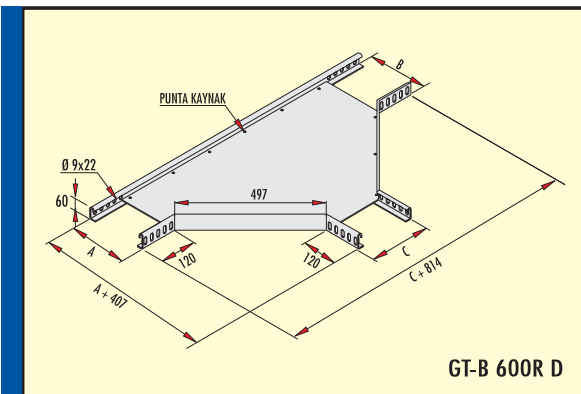

### Ağır Hizmet T Bağlantı Elemanı 600 Radius (h=60 mm)

#### Heavy Duty Tees "T" Radius 600 (h=60 mm)

Сверхмощные «Т» образные соединительные элементы (Радиус 600)

Sipariş kodu Order code Код заявки	Ağırlık (Kg/ad.) Weight (Kg/unit) Вес (кг / шт)	A mm	B mm	C mm	e mm	Price list прайс-лист шт / у.е.	
						Pre-Galvanized Предв. Цинк-ия	Hot dip Galvanized гор.оцинк. HDZ
GT-B5 600R D	4,600	54	54	54	1	36,80	55,20
GT-B10 600R D	5,850	104	104	104	1.5	46,80	70,20
GT-B20 600R D	8,450	205	205	205	1.5	67,60	101,40
GT-B30 600R D	14,250	305	305	305	2	114,00	171,00
GT-B40 600R D	17,600	405	405	405	2	140,80	211,20
GT-B50 600R D	19,650	506	506	506	2	157,20	235,80
GT-B60 600R D	23,500	606	606	606	2	188,00	282,00

Kaplama : TS 914 EN ISO-1461 (BS-EN-ISO-1461) Sıcak Daldırma Galvaniz.  
Bu Ürünler İsteğe Bağlı Olarak Pregalvaniz ve CORTEN-A Saçdan İmal Edilebilir.

Coating : TS 914 EN ISO-1461 (BS-EN-ISO-1461) Hot Dip Galvanized  
These products can be produced from Pregalvanized or CORTEN-A Steel according to the requirements.

Talep üzerine tüm ürünler RODINO 50® malzemesi ile kaplanarak (max) 400°C ısıya, asit, tuz ve kum etkilerine karşı mukavemet sağlar.

In case of required all type of materials can be coated with RODINO 50® which will give on extra resistant at effect of 400°C heat, acid, salt and sand for the material.

**AĞIR HİZMET DÖRTLÜ BAĞLANTI ELEMANI** Heavy Duty Crossing  
Сверхмощные крестообразные соединительные элементы

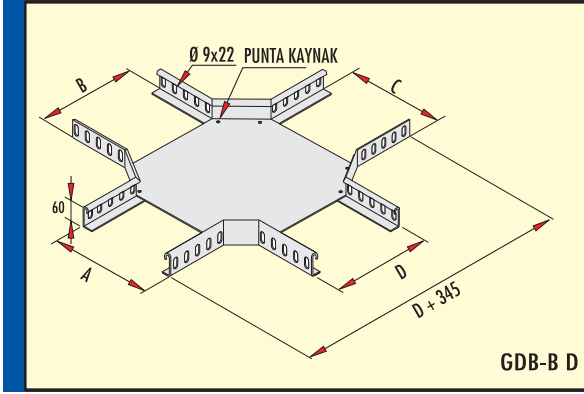

**Ağır Hizmet Dörtlü Bağlantı Elemanı (h=60 mm)**  
Heavy Duty Crossing (h=60 mm)

Сверхмощные крестообразные соединительные элементы

Sipariş kodu Order code Код заявки	Ağırlık (Kg/ad.) Weight (Kg/unit) Вес (кг/шт)	A mm	B mm	C mm	D mm	e mm	Price list прайс-лист шт./у.е.	
							Pre-Galvanized Предв. Цинк-ия	Hot dip Galvanized гор.оцинк. HDZ
GDB-B5 D	1,478	54	54	54	54	1	11,76	17,64
GDB-B10 D	1,990	104	104	104	104	1.5	15,92	23,88
GDB-B20 D	2,750	205	205	205	205	1.5	22,00	33,00
GDB-B30 D	4,600	305	305	305	305	2	36,80	55,20
GDB-B40 D	6,500	405	405	405	405	2	52,00	78,00
GDB-B50 D	8,200	506	506	506	506	2	65,60	98,40
GDB-B60 D	11,200	606	606	606	606	2	89,60	134,40

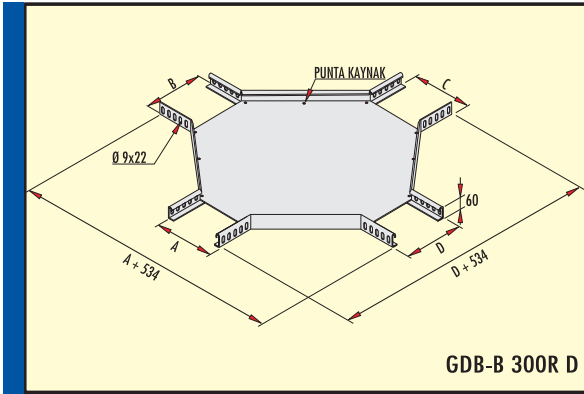

**Ağır Hizmet Dörtlü Bağlantı Elemanı 300 Radius (h=60 mm)**  
Heavy Duty Crossing Radius 300 (h=60 mm)

Сверхмощные крестообразные соединительные элементы (Радиус 300)

Sipariş kodu Order code Код заявки	Ağırlık (Kg/ad.) Weight (Kg/unit) Вес (кг/шт)	A mm	B mm	C mm	D mm	e mm	Price list прайс-лист шт./у.е.	
							Pre-Galvanized Предв. Цинк-ия	Hot dip Galvanized гор.оцинк. HDZ
GDB-B5 300R D	3,200	54	54	54	54	1	25,60	38,40
GDB-B10 300R D	3,900	104	104	104	104	1.5	31,20	46,80
GDB-B20 300R D	5,200	205	205	205	205	1.5	41,60	62,40
GDB-B30 300R D	8,900	305	305	305	305	2	71,20	106,80
GDB-B40 300R D	11,400	405	405	405	405	2	91,20	136,80
GDB-B50 300R D	14,200	506	506	506	506	2	113,60	170,40
GDB-B60 300R D	17,400	606	606	606	606	2	139,20	208,80

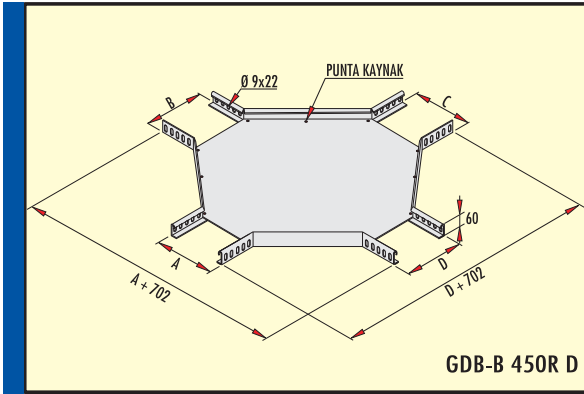

**Ağır Hizmet Dörtlü Bağlantı Elemanı 450 Radius (h=60 mm)**  
Heavy Duty Crossing Radius 450 (h=60 mm)

Сверхмощные крестообразные соединительные элементы (Радиус 450)

Sipariş kodu Order code Код заявки	Ağırlık (Kg/ad.) Weight (Kg/unit) Вес (кг/шт)	A mm	B mm	C mm	D mm	e mm	Price list прайс-лист шт./у.е.	
							Pre-Galvanized Предв. Цинк-ия	Hot dip Galvanized гор.оцинк. HDZ
GDB-B5 450R D	4,200	54	54	54	54	1	33,60	50,40
GDB-B10 450R D	5,400	104	104	104	104	1.5	43,20	64,80
GDB-B20 450R D	7,800	205	205	205	205	1.5	62,40	93,60
GDB-B30 450R D	13,100	305	305	305	305	2	96,80	145,20
GDB-B40 450R D	16,200	405	405	405	405	2	129,60	194,40
GDB-B50 450R D	19,250	506	506	506	506	2	154,00	231,00
GDB-B60 450R D	23,050	606	606	606	606	2	184,40	276,60

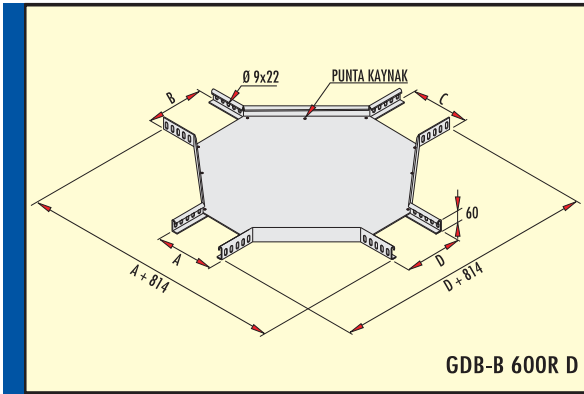

**Ağır Hizmet Dörtlü Bağlantı Elemanı 600 Radius (h=60 mm)**  
Heavy Duty Crossing Radius 600 (h=60 mm)

Сверхмощные крестообразные соединительные элементы (Радиус 600)

Sipariş kodu Order code Код заявки	Ağırlık (Kg/ad.) Weight (Kg/unit) Вес (кг/шт)	A mm	B mm	C mm	D mm	e mm	Price list прайс-лист шт./у.е.	
							Pre-Galvanized Предв. Цинк-ия	Hot dip Galvanized гор.оцинк. HDZ
GDB-B5 600R D	5,700	54	54	54	54	1	45,60	68,40
GDB-B10 600R D	7,200	104	104	104	104	1.5	57,60	86,40
GDB-B20 600R D	10,000	205	205	205	205	1.5	80,00	120,00
GDB-B30 600R D	16,300	305	305	305	305	2	130,40	195,60
GDB-B40 600R D	21,500	405	405	405	405	2	172,00	258,00
GDB-B50 600R D	23,650	506	506	506	506	2	189,20	283,80
GDB-B60 600R D	27,900	606	606	606	606	2	223,20	334,80

Kaplama : TS 914 EN ISO-1461 (BS-EN-ISO-1461) Sıcak Daldırma Galvaniz.  
Bu Ürünler İsteğe Bağlı Olarak Pregalvaniz ve CORTEN-A Saçdan İmal Edilebilir.

Coating : TS 914 EN ISO-1461 (BS-EN-ISO-1461) Hot Dip Galvanized  
These products can be produced from Pregalvanized or CORTEN-A Steel according to the requirements.

Talep üzerine tüm ürünler RODINO 50® malzemesi ile kaplanarak (max) 400°C ısıya, asit, tuz ve kum etkilerine karşı mukavemet sağlar.  
In case of required all type of materials can be coated with RODINO 50® which will give on extra resistant at effect of 400°C heat, acid, salt and sand for the material.

## 135° AĞIR HİZMET DÖNÜŞ ELEMANI

## 135° Heavy Duty Flat Bend

Плоский Изгиб и Покрытие 135°

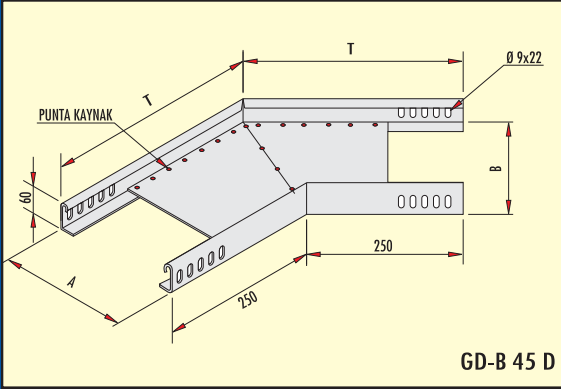

### 135° Ağır Hizmet Dönüş Elemanı (h=60 mm) 135° Heavy Duty Flat Bend (h=60 mm)

Sipariş kodu Order code Код заявки	Ağırlık (Kg/ad.) Weight (Kg/unit) Вес (кг/шт)	A mm	B mm	T mm	e mm	Price list прайс-лист шт/у.е.	
						Pre-Galvanized Предв. Цинк-ия	Hot dip Galvanized гор.оцинк. HDZ
GD-B5-45 D	1,050	54	54	271	1	8,40	12,60
GD-B10-45 D	1,800	104	104	291	1,5	14,40	21,60
GD-B20-45 D	2,100	205	205	333	1,5	16,80	25,20
GD-B30-45 D	3,250	305	305	374	2	26,00	39,00
GD-B40-45 D	4,000	405	405	416	2	32,00	48,00
GD-B50-45 D	5,700	506	506	457	2	45,60	68,40
GD-B60-45 D	6,950	606	606	499	2	55,60	83,40

## AĞIR HİZMET İÇ-DIŞ BÜKEY ELEMANI

## Heavy Duty Inside and Outside Vertical Bend

Внутри и снаружи Вертикального Изгиба и Покрытий

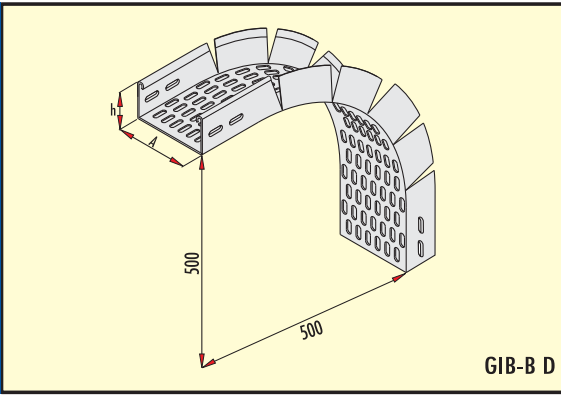

### Ağır Hizmet İç-Dış Bükey Elemanı (h=60 mm) Heavy Duty Inside and Outside Vertical Bend (h=60 mm)

Sipariş kodu Order code Код заявки	Ağırlık (Kg/ad.) Weight (Kg/unit) Вес (кг/шт)	A mm	h mm	e mm	Price list прайс-лист шт/у.е.	
					Pre-Galvanized Предв. Цинк-ия	Hot dip Galvanized гор.оцинк. HDZ
GIB-B5 D	1,900	50	60	1,5	15,20	22,80
GIB-B10 D	2,600	100	60	1,5	20,80	31,20
GIB-B20 D	3,500	200	60	1,5	28,00	42,00
GIB-B30 D	5,750	300	60	2	46,00	69,00
GIB-B40 D	6,750	400	60	2	54,00	81,00
GIB-B50 D	8,250	500	60	2	66,00	99,00
GIB-B60 D	9,600	600	60	2	76,80	115,20

## DIKEY "T"

## Vertical "Tee"

Вертикальная "Мишень"

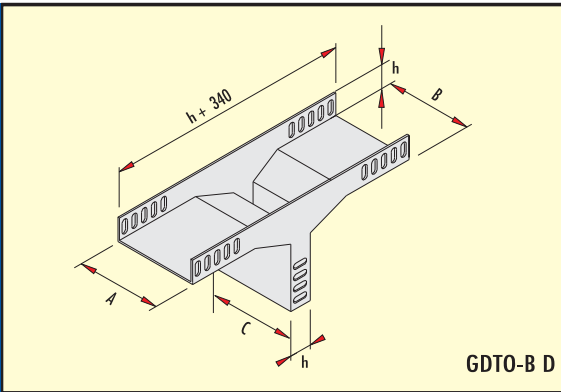

### Dikey "T" Ortadan (h=60 mm) Vertical "Tee" Center (h=60 mm) Вертикальная "Мишень"

Sipariş kodu Order code Код заявки	Ağırlık (Kg/ad.) Weight (Kg/unit) Вес (кг/шт)	A-B-C mm	h mm	e mm	Price list прайс-лист шт/у.е.	
					Pre-Galvanized Предв. Цинк-ия	Hot dip Galvanized гор.оцинк. HDZ
GDTO-B5 D	1,250	50	60	1,5	8,80	13,00
GDTO-B10 D	1,780	100	60	1,5	17,85	24,00
GDTO-B20 D	2,600	200	60	1,5	26,00	36,00
GDTO-B30 D	3,425	300	60	2	34,25	47,00
GDTO-B40 D	5,660	400	60	2	56,60	78,00
GDTO-B50 D	6,750	500	60	2	67,50	95,00
GDTO-B60 D	7,445	600	60	2	74,50	109,00

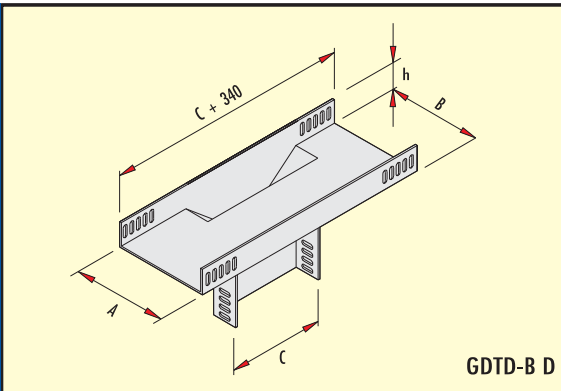

### Dikey "T" Duvardan (h=60 mm) Vertical "Tee" Wall (h=60 mm) Вертикальная "Мишень"

Sipariş kodu Order code Код заявки	Ağırlık (Kg/ad.) Weight (Kg/unit) Вес (кг/шт)	A-B-C mm	h mm	e mm	Price list прайс-лист шт/у.е.	
					Pre-Galvanized Предв. Цинк-ия	Hot dip Galvanized гор.оцинк. HDZ
GDTD-B5 D	1,350	50	60	1,5	9,00	14,00
GDTD-B10 D	1,800	100	60	1,5	18,00	25,00
GDTD-B20 D	3,000	200	60	1,5	30,00	42,00
GDTD-B30 D	4,520	300	60	2	45,20	63,00
GDTD-B40 D	8,360	400	60	2	86,60	116,00
GDTD-B50 D	11,050	500	60	2	110,50	155,00
GDTD-B60 D	14,080	600	60	2	140,80	197,00

Kaplama : TS 914 EN ISO-1461 (BS-EN-ISO-1461) Sıcak Daldırma Galvaniz.  
Bu ürünler isteğe bağlı olarak Pregalvaniz ve CORTEN-A Saçdan İmal Edilebilir.

Coating : TS 914 EN ISO-1461 (BS-EN-ISO-1461) Hot Dip Galvanized  
These products can be produced from Pregalvanized or CORTEN-A Steel according to the requirements.

Talep üzerine tüm ürünler RODINO 50® malzemesi ile kaplanarak (max) 400°C ısıya, asit, tuz ve kum etkilerine karşı mukavemet sağlar.

In case of required all type of materials can be coated with RODINO 50® which will give on extra resistant at effect of 400°C heat, acid, salt and sand for the material.



# RADÜSLÜ DÖNÜŞ ELEMANLARI

## Flat Bends

## Угловые элементы

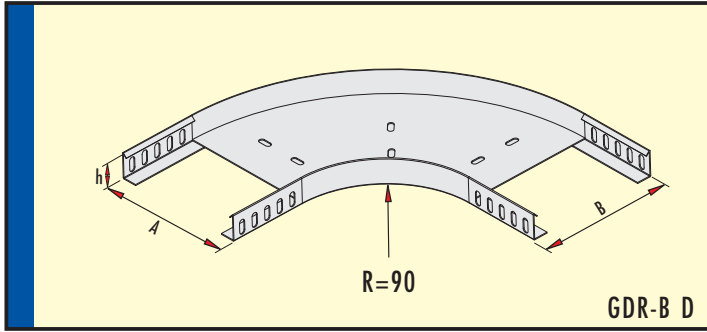

GDR-B D

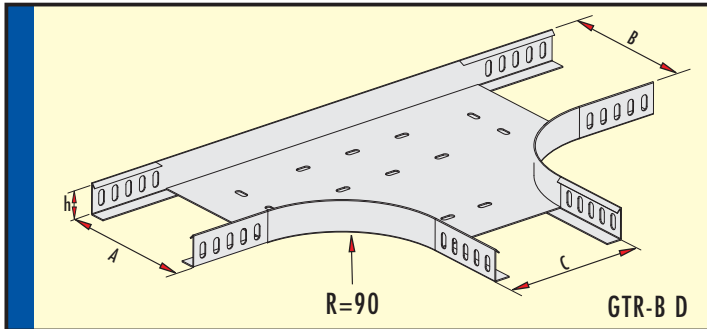

GTR-B D

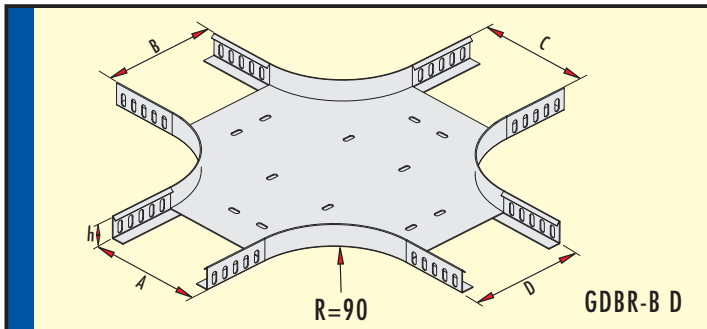

GDBR-B D

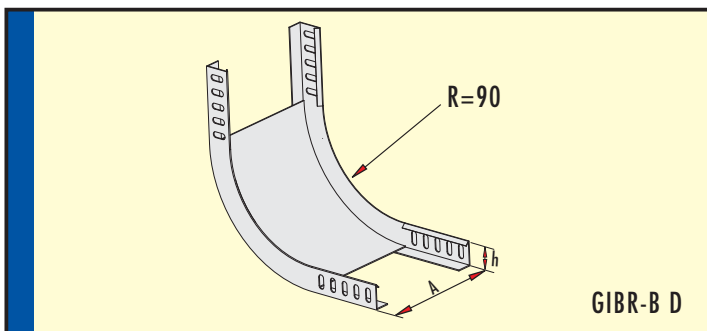

GIBR-B D

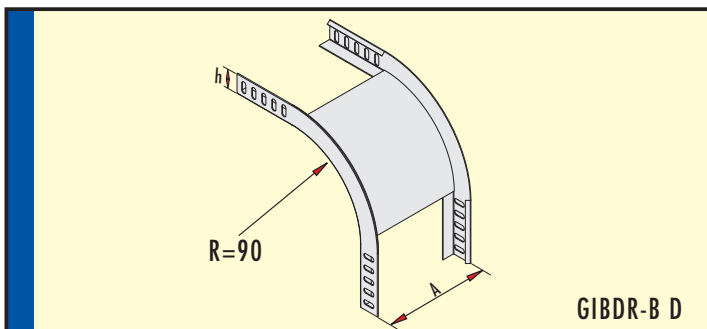

GIBDR-B D

### 90° Dönüş Elemanı 90° Flat Bend

угловые элементы 90°

Sipariş kodu Order code Код заявки	Ağırlık (Kg/ad.) Weight (Kg/unit) Вес (кг/шт)	A-B mm	h mm	e mm	Price list прайс-лист шт./у.е.	
					Pre-Galvanized Предв. Цинк-ия	Hot dip Galvanized гор.оцинк. HDZ
GDR-B5D	1,000	55	60	1.5		12,00
GDR-B10D	1,280	105	60	1.5		15,36
GDR-B20D	1,910	205	60	1.5		22,92
GDR-B30D	3,620	305	60	2		43,44
GDR-B40D	4,990	405	60	2		59,88
GDR-B50D	6,520	505	60	2		78,24
GDR-B60D	8,830	605	60	2		105,96

### T Bağlantı Elemanı Tees "T"

«Т» образные соединительные элементы

Sipariş kodu Order code Код заявки	Ağırlık (Kg/ad.) Weight (Kg/unit) Вес (кг/шт)	A-B-C mm	h mm	e mm	Price list прайс-лист шт./у.е.	
					Pre-Galvanized Предв. Цинк-ия	Hot dip Galvanized гор.оцинк. HDZ
GTR-B5D	1,500	55	60	1.5		18,00
GTR-B10D	1,920	105	60	1.5		23,04
GTR-B20D	2,710	205	60	1.5		32,52
GTR-B30D	4,980	305	60	2		59,76
GTR-B40D	6,670	405	60	2		80,04
GTR-B50D	8,670	505	60	2		104,04
GTR-B60D	11,000	605	60	2		132,00

### Dörtlü Bağlantı Elemanı Crossing Element

крестообразные соединительные элементы

Sipariş kodu Order code Код заявки	Ağırlık (Kg/ad.) Weight (Kg/unit) Вес (кг/шт)	A-B-C-D mm	h mm	e mm	Price list прайс-лист шт./у.е.	
					Pre-Galvanized Предв. Цинк-ия	Hot dip Galvanized гор.оцинк. HDZ
GDBR-B5D	2,000	55	60	1.5		24,00
GDBR-B10D	2,340	105	60	1.5		28,08
GDBR-B20D	3,130	205	60	1.5		37,56
GDBR-B30D	5,400	305	60	2		64,80
GDBR-B40D	7,100	405	60	2		85,20
GDBR-B50D	9,100	505	60	2		109,20
GDBR-B60D	11,400	605	60	2		136,80

### İç Bükey Elemanı Inside Vertical Bend

Внутри и снаружи Вертикальных Изгибов

Sipariş kodu Order code Код заявки	Ağırlık (Kg/ad.) Weight (Kg/unit) Вес (кг/шт)	A mm	h mm	e mm	Price list прайс-лист шт./у.е.	
					Pre-Galvanized Предв. Цинк-ия	Hot dip Galvanized гор.оцинк. HDZ
GIBR-B5D	1,100	55	60	1.5		13,20
GIBR-B10D	1,260	105	60	1.5		15,12
GIBR-B20D	1,560	205	60	1.5		18,72
GIBR-B30D	2,460	305	60	2		29,52
GIBR-B40D	2,840	405	60	2		34,08
GIBR-B50D	3,230	505	60	2		38,76
GIBR-B60D	3,630	605	60	2		43,56

### Dış Bükey Elemanı Outside Vertical Bend

Внутри и снаружи Вертикальных Изгибов

Sipariş kodu Order code Код заявки	Ağırlık (Kg/ad.) Weight (Kg/unit) Вес (кг/шт)	A mm	h mm	e mm	Price list прайс-лист шт./у.е.	
					Pre-Galvanized Предв. Цинк-ия	Hot dip Galvanized гор.оцинк. HDZ
GIBDR-B5D	0,980	55	60	1.5		11,76
GIBDR-B10D	1,100	105	60	1.5		13,20
GIBDR-B20D	1,260	205	60	1.5		15,12
GIBDR-B30D	1,900	305	60	2		22,80
GIBDR-B40D	2,150	405	60	2		25,80
GIBDR-B50D	2,370	505	60	2		28,44
GIBDR-B60D	2,600	605	60	2		31,20

Bağlantı elemanları isteğe bağlı olarak 150-300-450-600-900 Radüslü imal edilir.

Circler can be produced with 150-300-450-600-900 Radius.

Соединительные элементы по заказу можно изготовить радиусом 150-300-450-600-900

ĞİR HİZMET TİPİ KABLO KANALLARI

Heavy Duty Cable Trays

Сверхмощные кабельные лотки

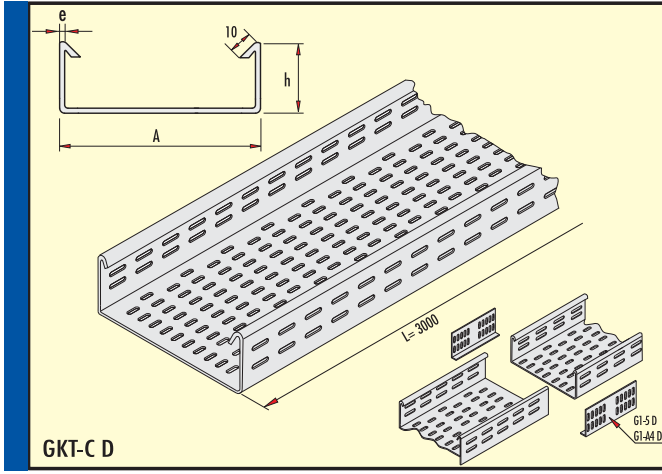

Ğir Hizmet Tipi Kablo Kanalı (h=100 mm)  
Heavy Duty Cable Tray (h=100 mm)  
Сверхмощные кабельные лотки

Sipariş kodu Order code Код заявки	Ağırlık (Kg/mt.) Weight (Kg/mt) Вес (кг/м)	A mm	h mm	e mm	Price list прайс-лист М/у.е.	
					Pre-Galvanized Предв. Цинк-ия	Hot dip Galvanized гор.оцинк. HDZ
GKT-C10 D	3.600	100	100	1.5	18,00	32,40
GKT-C20 D	4.500	200	100	1.5	22,50	40,50
GKT-C30 D	7.550	300	100	2	37,75	68,00
GKT-C40 D	8.800	400	100	2	44,00	79,00
GKT-C50 D	10.200	500	100	2	51,00	92,00
GKT-C60 D	11.900	600	100	2	59,50	107,00

DELİKSİZ ĞİR HİZMET KAPAKLI TİP KABLO KANALLARI  
Сверхмощные кабельные лотки с крышкой

Non Perforated Heavy Duty Cable Trays With Cover

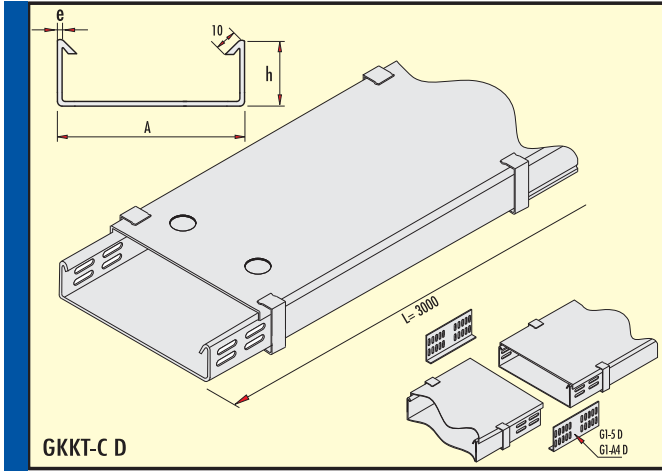

Deliksiz Ğir Hizmet Tipi Kablo Kanalı (h=100 mm)  
Non Perforated Heavy Duty Cable Trays With Cover (h=100 mm)  
Сверхмощные кабельные лотки с крышкой

Sipariş kodu Order code Код заявки	Ağırlık (Kg/mt.) Weight (Kg/mt) Вес (кг/м)	A mm	h mm	e mm	Price list прайс-лист М/у.е.	
					Pre-Galvanized Предв. Цинк-ия	Hot dip Galvanized гор.оцинк. HDZ
GKKT-C10 D	5.000	100	100	1.5	20,00	45,00
GKKT-C20 D	6.350	200	100	1.5	25,40	57,00
GKKT-C30 D	11.550	300	100	2	46,00	104,00
GKKT-C40 D	15.900	400	100	2	63,60	143,00
GKKT-C50 D	19.100	500	100	2	76,40	172,00
GKKT-C60 D	22.200	600	100	2	89,00	200,00

EK PARÇASI

Joining Piece

Соединительные элементы

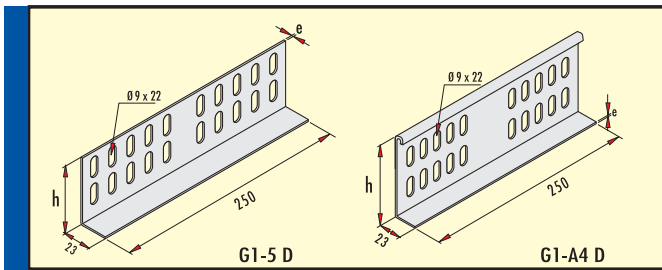

Ek Parçası (h=100 mm)  
Joining Piece (h=100 mm)

Соединительные элементы

Sipariş kodu Order code Код заявки	Ağırlık (Kg/ad.) Weight (Kg/unit) Вес (кг/шт)	A mm	e mm	Price list прайс-лист шт/у.е.	
				Pre-Galvanized Предв. Цинк-ия	Hot dip Galvanized гор.оцинк. HDZ
G1 - 5 D	0.420	100	2	4,20	5,90
G1 - A4 D	0.560	104	2	5,60	7,80

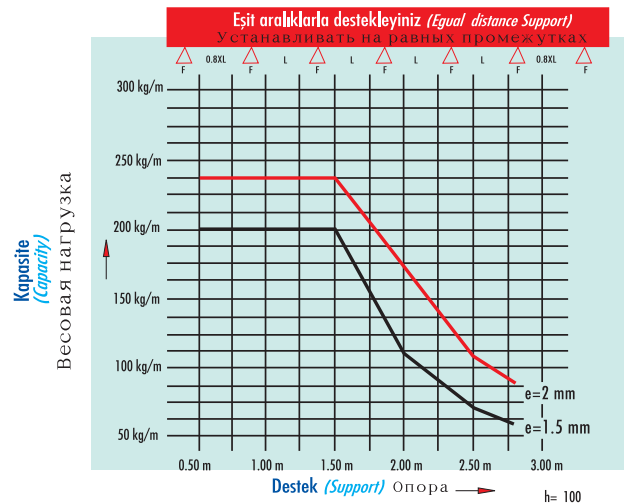

Kaplama : TS 914 EN ISO-1461 (BS-EN-ISO-1461) Sıcak Daldırma Galvaniz.  
Bu ürünler isteğe Bağlı Olarak Pregalvaniz ve CORTEN-A Saçdan İmal Edilebilir.

Coating : TS 914 EN ISO-1461 (BS-EN-ISO-1461) Hot Dip Galvanized  
These products can be produced from Pregalvanized or CORTEN-A Steel according to the requirements.

Talep üzerine tüm ürünler RODINO 50® malzemesi ile kaplanarak (max) 400°C ısıya, asit, tuz ve kum etkilerine karşı mukavemet sağlar.

In case of required all type of materials can be coated with RODINO 50® which will give on extra resistant at effect of 400°C heat, acid, salt and sand for the material.

AĞIR HİZMET 90° DÖNÜŞ ELEMANLARI

90° Heavy Duty Flat Bends

Сверхмощные угловые элементы 90°

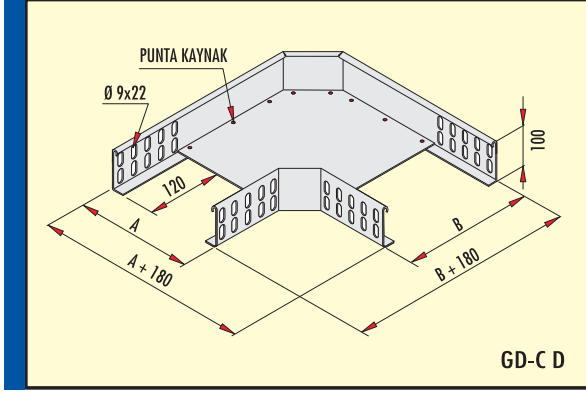

Ağır Hizmet 90° Dönüş Elemanı (h=100 mm)  
90° Heavy Duty Flat Bend (h=100 mm)  
Сверхмощные угловые элементы 90°

Sipariş kodu Order code Код заявки	Ağırlık (Kg/ad.) Weight (Kg/unit) Вес (кг/шт)	A mm	B mm	e mm	Price list прайс-лист шт./у.е.	
					Pre-Galvanized Предв. Цинк-ия	Hot dip Galvanized гор.оцинк. HDZ
GD-C10 D	1,650	104	104	1,5	13,20	19,80
GD-C20 D	2,400	205	205	1,5	19,20	28,80
GD-C30 D	4,300	305	305	2	34,40	51,60
GD-C40 D	5,850	405	405	2	46,80	70,20
GD-C50 D	7,650	506	506	2	61,20	91,80
GD-C60 D	9,750	606	606	2	78,00	117,00

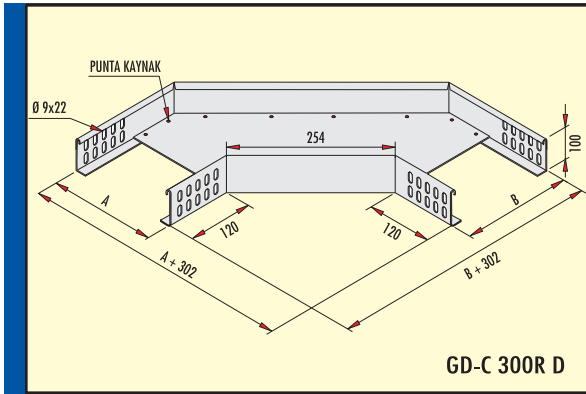

Ağır Hizmet 90° Dönüş Elemanı 300 Radüs (h=100 mm)  
90° Heavy Duty Flat Bend Radius 300 (h=100 mm)  
Сверхмощные угловые элементы 90° (Радиус 300)

Sipariş kodu Order code Код заявки	Ağırlık (Kg/ad.) Weight (Kg/unit) Вес (кг/шт)	A mm	B mm	e mm	Price list прайс-листу шт. у.е.	
					Pre-Galvanized Предв. Цинк-ия	Hot dip Galvanized гор.оцинк. HDZ
GD-C10 300R D	2,180	104	104	1,5	17,44	26,16
GD-C20 300R D	3,200	205	205	1,5	25,60	38,40
GD-C30 300R D	6,200	305	305	2	49,60	74,40
GD-C40 300R D	7,450	405	405	2	59,60	89,40
GD-C50 300R D	10,550	506	506	2	84,40	126,60
GD-C60 300R D	12,500	606	606	2	100,00	150,00

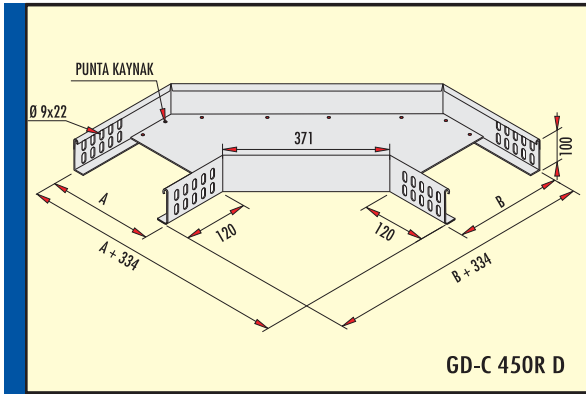

Ağır Hizmet 90° Dönüş Elemanı 450 Radüs (h=100 mm)  
90° Heavy Duty Flat Bend Radius 450 (h=100 mm)  
Сверхмощные угловые элементы 90° Радиус 450

Sipariş kodu Order code Код заявки	Ağırlık (Kg/ad.) Weight (Kg/unit) Вес (кг/шт)	A mm	B mm	e mm	Price list прайс-листу шт. у.е.	
					Pre-Galvanized Предв. Цинк-ия	Hot dip Galvanized гор.оцинк. HDZ
GD-C10 450R D	3,650	104	104	1,5	29,20	43,80
GD-C20 450R D	4,600	205	205	1,5	36,80	55,20
GD-C30 450R D	6,850	305	305	2	54,80	82,20
GD-C40 450R D	8,850	405	405	2	70,80	106,20
GD-C50 450R D	11,000	506	506	2	88,00	132,00
GD-C60 450R D	13,550	606	606	2	108,40	162,60

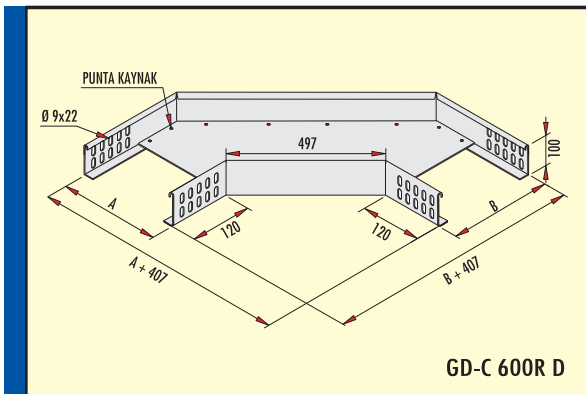

Ağır Hizmet 90° Dönüş Elemanı 600 Radüs (h=100 mm)  
90° Heavy Duty Flat Bend Radius 600 (h=100 mm)  
Сверхмощные угловые элементы 90° (Радиус 600)

Sipariş kodu Order code Код заявки	Ağırlık (Kg/ad.) Weight (Kg/unit) Вес (кг/шт)	A mm	B mm	e mm	Price list прайс-листу шт. у.е.	
					Pre-Galvanized Предв. Цинк-ия	Hot dip Galvanized гор.оцинк. HDZ
GD-C10 600R D	4,350	104	104	1,5	34,80	52,20
GD-C20 600R D	5,750	205	205	1,5	46,00	69,00
GD-C30 600R D	8,000	305	305	2	64,00	96,00
GD-C40 600R D	10,200	405	405	2	81,60	122,40
GD-C50 600R D	12,600	506	506	2	100,80	151,20
GD-C60 600R D	15,400	606	606	2	123,20	184,80

Kaplama : TS 914 EN ISO-1461 (BS-EN-ISO-1461) Sıcak Daldırma Galvaniz.  
Bu Ürünler İsteğe Bağlı Olarak Pregalvaniz ve CORTEN-A Saçdan İmal Edilebilir.

Coating : TS 914 EN ISO-1461 (BS-EN-ISO-1461) Hot Dip Galvanized  
These products can be produced from Pregalvanized or CORTEN-A Steel according to the requirements.

Talep üzerine tüm ürünler RODINO 50® malzemesi ile kaplanarak (max) 400°C ısıya, asit, tuz ve kum etkilerine karşı mukavemet sağlar.

In case of required all type of materials can be coated with RODINO 50® which will give on extra resistant at effect of 400°C heat, acid, salt and sand for the material.



## AĞIR HİZMET T BAĞLANTI ELEMANLARI

## Heavy Duty Tees "T"

Сверхмощные «Т» образные соединительные элементы

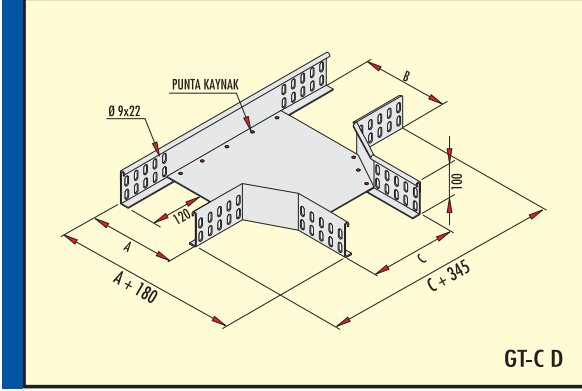

### Ağır Hizmet T Bağlantı Elemanı (h=100 mm) Heavy Duty Tees "T" (h=100 mm)

Сверхмощные «Т» образные соединительные элементы

Sipariş kodu Order code Код заявки	Ağırlık (Kg/ad.) Weight (Kg/unit) Вес (кг / шт)	A mm	B mm	C mm	e mm	Price list прайс-лист шт / у.е.	
						Pre-Galvanized Предв. Цинк-ия	Hot dip Galvanized гор.оцинк. HDZ
GT-C10 D	2,170	104	104	104	1.5	17,40	26,00
GT-C20 D	3,100	205	205	205	1.5	24,80	38,00
GT-C30 D	5,450	305	305	305	2	43,60	66,00
GT-C40 D	7,200	405	405	405	2	57,60	87,00
GT-C50 D	8,900	506	506	506	2	71,20	107,00
GT-C60 D	11,250	606	606	606	2	90,00	135,00

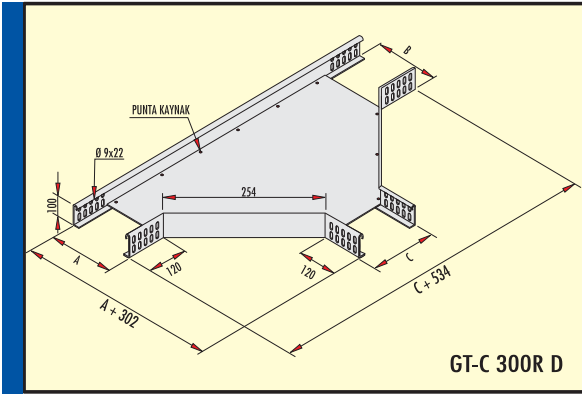

### Ağır Hizmet T Bağlantı Elemanı 300 Radüs (h=100 mm) Heavy Duty Tees "T" Radius 300 (h=100 mm)

Сверхмощные «Т» образные соединительные элементы (Радиус 300)

Sipariş kodu Order code Код заявки	Ağırlık (Kg/ad.) Weight (Kg/unit) Вес (кг / шт)	A mm	B mm	C mm	e mm	Price list прайс-листу шт у.е.	
						Pre-Galvanized Предв. Цинк-ия	Hot dip Galvanized гор.оцинк. HDZ
GT-C10 300R D	3,670	104	104	104	1.5	29,40	44,10
GT-C20 300R D	5,300	205	205	205	1.5	42,40	63,60
GT-C30 300R D	9,000	305	305	305	2	72,00	108,00
GT-C40 300R D	11,600	405	405	405	2	92,80	139,20
GT-C50 300R D	13,850	506	506	506	2	110,80	166,20
GT-C60 300R D	16,850	606	606	606	2	134,80	202,20

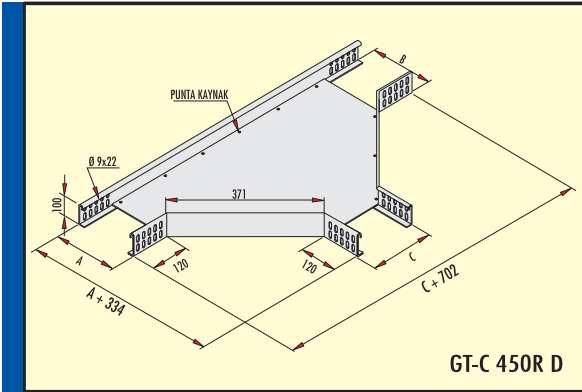

### Ağır Hizmet T Bağlantı Elemanı 450 Radüs (h=100 mm) Heavy Duty Tees "T" Radius 450 (h=100 mm)

Сверхмощные «Т» образные соединительные элементы (Радиус 450)

Sipariş kodu Order code Код заявки	Ağırlık (Kg/ad.) Weight (Kg/unit) Вес (кг / шт)	A mm	B mm	C mm	e mm	Price list прайс-листу шт у.е.	
						Pre-Galvanized Предв. Цинк-ия	Hot dip Galvanized гор.оцинк. HDZ
GT-C10 450R D	5,200	104	104	104	1.5	41,60	62,40
GT-C20 450R D	7,600	205	205	205	1.5	60,80	91,20
GT-C30 450R D	12,700	305	305	305	2	101,60	152,40
GT-C40 450R D	15,600	405	405	405	2	124,80	187,20
GT-C50 450R D	17,600	506	506	506	2	140,80	211,20
GT-C60 450R D	21,000	606	606	606	2	168,00	252,00

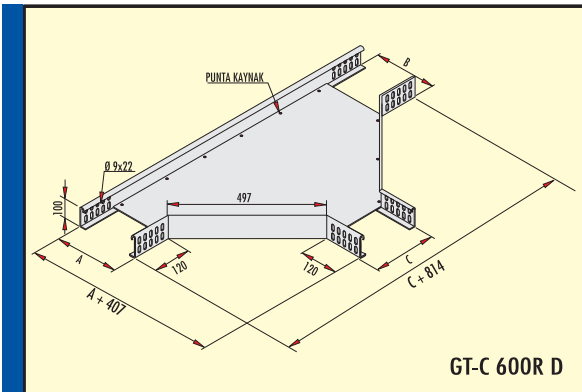

### Ağır Hizmet T Bağlantı Elemanı 600 Radüs (h=100 mm) Heavy Duty Tees "T" Radius 600 (h=100 mm)

Сверхмощные «Т» образные соединительные элементы (Радиус 600)

Sipariş kodu Order code Код заявки	Ağırlık (Kg/ad.) Weight (Kg/unit) Вес (кг / шт)	A mm	B mm	C mm	e mm	Price list прайс-листу шт у.е.	
						Pre-Galvanized Предв. Цинк-ия	Hot dip Galvanized гор.оцинк. HDZ
GT-C10 600R D	6,900	104	104	104	1.5	55,20	82,80
GT-C20 600R D	9,800	205	205	205	1.5	78,40	117,60
GT-C30 600R D	16,200	305	305	305	2	129,60	194,40
GT-C40 600R D	18,600	405	405	405	2	148,80	223,20
GT-C50 600R D	21,600	506	506	506	2	172,80	259,20
GT-C60 600R D	25,500	606	606	606	2	204,00	306,00

Kaplama : TS 914 EN ISO-1461 (BS-EN-ISO-1461) Sıcak Daldırma Galvaniz.  
Bu ürünler isteğe Bağlı Olarak Pregalvaniz ve CORTEN-A Saçdan İmal Edilebilir.

Coating : TS 914 EN ISO-1461 (BS-EN-ISO-1461) Hot Dip Galvanized  
These products can be produced from Pregalvanized or CORTEN-A Steel according to the requirements.

Talep üzerine tüm ürünler RODINO 50® malzemesi ile kaplanarak (max) 400°C ısıya, asit, tuz ve kum etkilerine karşı mukavemet sağlar.

In case of required all type of materials can be coated with RODINO 50® which will give on extra resistant at effect of 400°C heat, acid, salt and sand for the material.

**AĞIR HİZMET DÖRTLÜ BAĞLANTI ELEMANI** *Heavy Duty Crossing*  
Сверхмощные крестообразные соединительные элементы

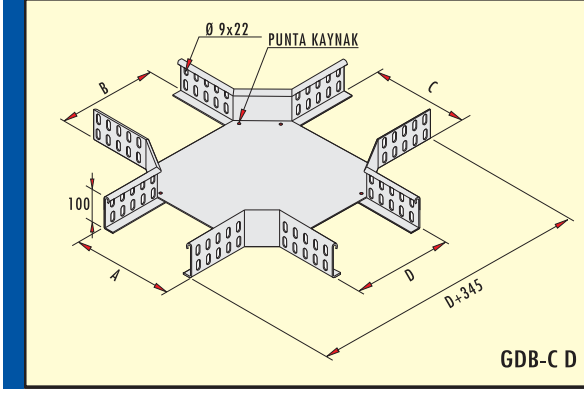

**Ağır Hizmet Dörtlü Bağlantı Elemanı (h=100 mm)**  
*Heavy Duty Crossing (h=100 mm)*

Сверхмощные крестообразные соединительные элементы

Sipariş kodu Order code Код заявки	Ağırlık (Kg/ad.) Weight (Kg/unit) Вес (кг / шт)	A mm	B mm	C mm	D mm	e mm	Price list прайс-листуш т у.е.	
							Pre-Galvanized Предв. Цинк-ия	Hot dip Galvanized гор.оцинк. HDZ
GDB-C10 D	2,000	104	104	104	104	1.5	16,00	24,00
GDB-C20 D	3,400	205	205	205	205	1.5	27,20	40,80
GDB-C30 D	5,650	305	305	305	305	2	45,20	67,80
GDB-C40 D	7,300	405	405	405	405	2	58,40	87,60
GDB-C50 D	8,800	506	506	506	506	2	70,40	105,60
GDB-C60 D	11,000	606	606	606	606	2	88,00	132,00

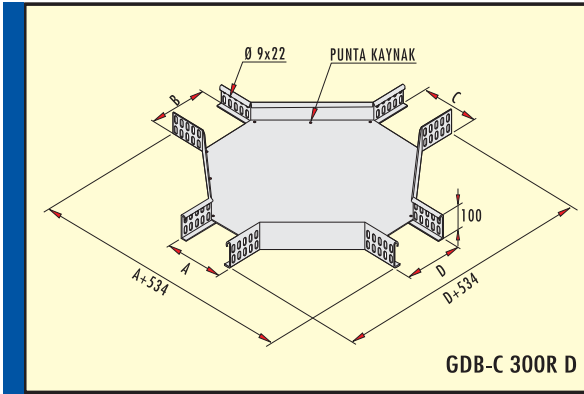

**Ağır Hizmet Dörtlü Bağlantı Elemanı 300 Radüs (h=100 mm)**  
*Heavy Duty Crossing Radius 300 (h=100 mm)*

Сверхмощные крестообразные соединительные элементы (Радиус 300)

Sipariş kodu Order code Код заявки	Ağırlık (Kg/ad.) Weight (Kg/unit) Вес (кг / шт)	A mm	B mm	C mm	D mm	e mm	Price list прайс-листуш т у.е.	
							Pre-Galvanized Предв. Цинк-ия	Hot dip Galvanized гор.оцинк. HDZ
GDB-C10 300R D	4,500	104	104	104	104	1.5	36,00	54,00
GDB-C20 300R D	6,500	205	205	205	205	1.5	52,00	78,00
GDB-C30 300R D	8,900	305	305	305	305	2	71,20	106,80
GDB-C40 300R D	10,500	405	405	405	405	2	84,00	126,00
GDB-C50 300R D	13,100	506	506	506	506	2	104,80	157,20
GDB-C60 300R D	18,400	606	606	606	606	2	147,20	220,80

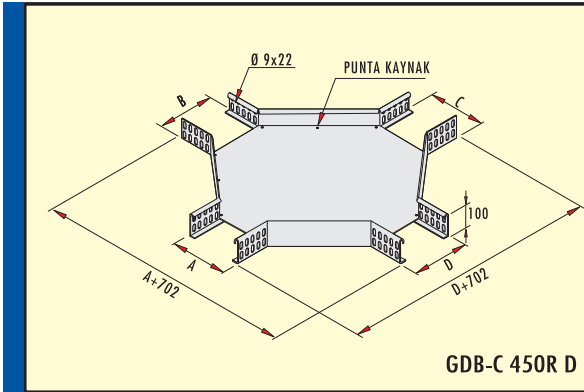

**Ağır Hizmet Dörtlü Bağlantı Elemanı 450 Radüs (h=100 mm)**  
*Heavy Duty Crossing Radius 450 (h=100 mm)*

Сверхмощные крестообразные соединительные элементы (Радиус 450)

Sipariş kodu Order code Код заявки	Ağırlık (Kg/ad.) Weight (Kg/unit) Вес (кг / шт)	A mm	B mm	C mm	D mm	e mm	Price list прайс-листуш т у.е.	
							Pre-Galvanized Предв. Цинк-ия	Hot dip Galvanized гор.оцинк. HDZ
GDB-C10 450R D	6,900	104	104	104	104	1.5	55,20	82,80
GDB-C20 450R D	9,200	205	205	205	205	1.5	73,60	110,40
GDB-C30 450R D	14,900	305	305	305	305	2	119,20	178,80
GDB-C40 450R D	18,000	405	405	405	405	2	144,00	216,00
GDB-C50 450R D	20,950	506	506	506	506	2	167,60	251,40
GDB-C60 450R D	24,750	606	606	606	606	2	198,00	297,00

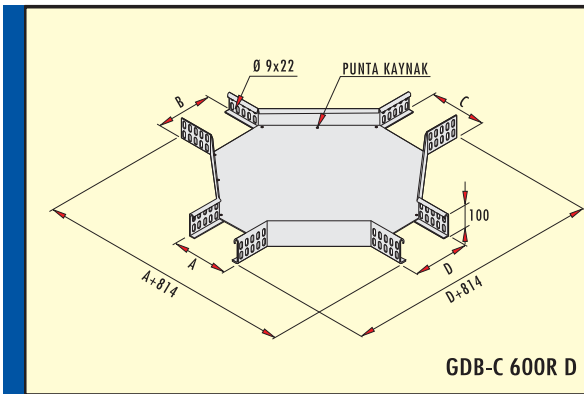

**Ağır Hizmet Dörtlü Bağlantı Elemanı 600 Radüs (h=100 mm)**  
*Heavy Duty Crossing Radius 600 (h=100 mm)*

Сверхмощные крестообразные соединительные элементы (Радиус 600)

Sipariş kodu Order code Код заявки	Ağırlık (Kg/ad.) Weight (Kg/unit) Вес (кг / шт)	A mm	B mm	C mm	D mm	e mm	Price list прайс-листуш т у.е.	
							Pre-Galvanized Предв. Цинк-ия	Hot dip Galvanized гор.оцинк. HDZ
GDB-C10 600R D	8,450	104	104	104	104	1.5	67,60	101,40
GDB-C20 600R D	11,550	205	205	205	205	1.5	92,40	138,60
GDB-C30 600R D	18,450	305	305	305	305	2	147,60	221,40
GDB-C40 600R D	22,200	405	405	405	405	2	177,60	266,40
GDB-C50 600R D	27,500	506	506	506	506	2	220,00	330,00
GDB-C60 600R D	31,750	606	606	606	606	2	254,00	381,00

Kaplama : TS 914 EN ISO-1461 (BS-EN-ISO-1461) Sıcak Daldırma Galvaniz.  
Bu Ürünler İsteğe Bağlı Olarak Pregalvaniz ve CORTEN-A Saçdan İmal Edilebilir.

Coating : TS 914 EN ISO-1461 (BS-EN-ISO-1461) Hot Dip Galvanized  
These products can be produced from Pregalvanized or CORTEN-A Steel according to the requirements.

Talep üzerine tüm ürünler RODINO 50® malzemesi ile kaplanarak (max) 400°C ısıya, asit, tuz ve kum etkilerine karşı mukavemet sağlar.  
In case of required all type of materials can be coated with RODINO 50® which will give on extra resistant at effect of 400°C heat, acid, salt and sand for the material.

135° AĞIR HİZMET DÖNÜŞ ELEMANI 135° Heavy Duyt Flat Bend

Плоский Изгиб и Покрытие 135°

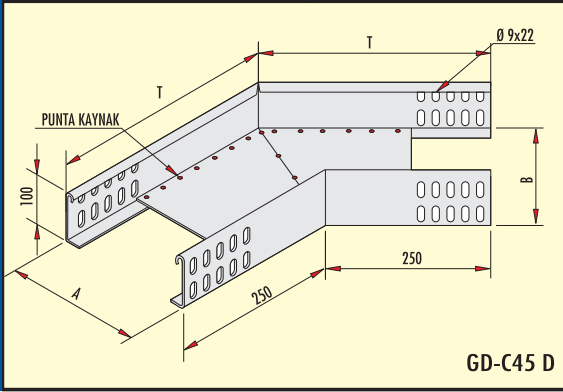

135° Ağır Hizmet Dönüş Elemanı (h=100 mm)  
135° Heavy Duyt Flat Bend (h=100 mm)  
Плоский Изгиб 135°

Sipariş kodu Order code Код заявки	Ağırlık (Kg/ad.) Weight (Kg/unit) Вес (кг/шт)	A mm	B mm	T mm	e mm	Price list прайс-листу шт. у.е.	
						Pre-Galvanized Предв. Цинк-ия	Hot dip Galvanized гор.оцинк. HDZ
GD-C10-45 D	2,000	104	104	291	1.5	16,00	24,00
GD-C20-45 D	2,600	205	205	333	1.5	20,80	31,20
GD-C30-45 D	4,300	305	305	374	2	34,40	51,60
GD-C40-45 D	5,400	405	405	416	2	43,20	64,80
GD-C50-45 D	6,500	506	506	457	2	52,00	78,00
GD-C60-45 D	7,850	606	606	499	2	62,80	94,20

AĞIR HİZMET İÇ-DIŞ BÜKEY ELEMANI Heavy Duyt Inside and Outside Vertical Bend

Внутри и снаружи Вертикального Изгиба и Покрытий

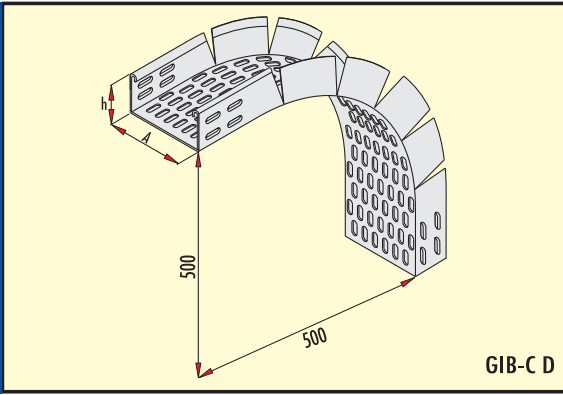

Ağır Hizmet İç-Dış Bükey Elemanı (h=100 mm)  
Heavy Duyt Inside and Outside Vertical Bend (h=100 mm)  
Внутри и снаружи Вертикальных Изгибов

Sipariş kodu Order code Код заявки	Ağırlık (Kg/ad.) Weight (Kg/unit) Вес (кг/шт)	A mm	h mm	e mm	Price list прайс-листу шт. у.е.	
					Pre-Galvanized Предв. Цинк-ия	Hot dip Galvanized гор.оцинк. HDZ
GIB-C10 D	3,300	100	100	1,5	26,40	39,60
GIB-C20 D	4,200	200	100	1,5	33,60	50,40
GIB-C30 D	7,000	300	100	2	56,00	84,00
GIB-C40 D	7,800	400	100	2	62,40	93,60
GIB-C50 D	9,050	500	100	2	72,40	108,60
GIB-C60 D	10,750	600	100	2	86,00	129,00

DIKEY "T" Vertical "Tee"

Вертикальная "Мишень"

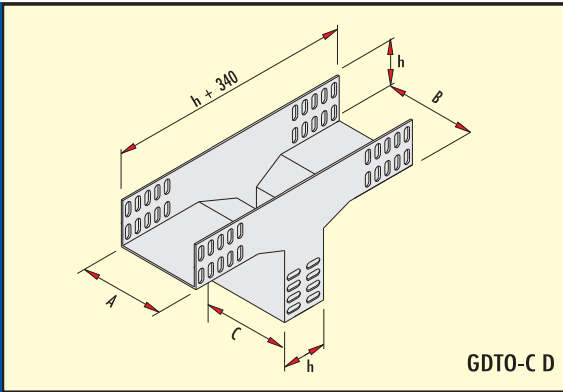

Dikey "T" Ortadan (h=100 mm)  
Vertical "Tee" Center (h=100 mm)  
Вертикальная "Мишень"

Sipariş kodu Order code Код заявки	Ağırlık (Kg/ad.) Weight (Kg/unit) Вес (кг/шт)	A-B-C mm	h mm	e mm	Price list прайс-листу шт. у.е.	
					Pre-Galvanized Предв. Цинк-ия	Hot dip Galvanized гор.оцинк. HDZ
GDTO-C10 D	2,480	100	100	1.5	24,80	34,75
GDTO-C20 D	3,300	200	100	1.5	33,00	46,00
GDTO-C30 D	4,120	300	100	2	41,20	57,70
GDTO-C40 D	6,600	400	100	2	66,00	92,00
GDTO-C50 D	7,690	500	100	2	76,90	108,00
GDTO-C60 D	8,450	600	100	2	84,50	118,00

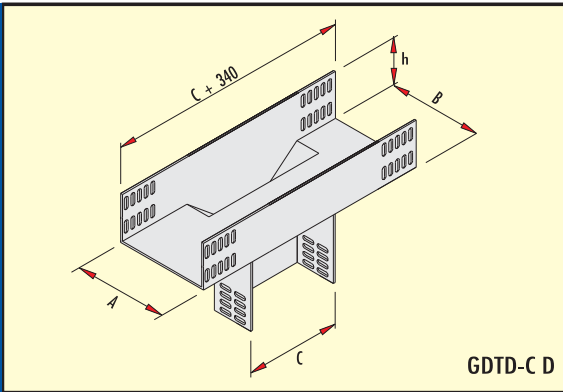

Dikey "T" Duvardan (h=100 mm)  
Vertical "Tee" Wall (h=100 mm)  
Вертикальная "Мишень"

Sipariş kodu Order code Код заявки	Ağırlık (Kg/ad.) Weight (Kg/unit) Вес (кг/шт)	A-B-C mm	h mm	e mm	Price list прайс-листу шт. у.е.	
					Pre-Galvanized Предв. Цинк-ия	Hot dip Galvanized гор.оцинк. HDZ
GDTD-C10 D	2,450	100	100	1.5	24,50	34,00
GDTD-C20 D	3,780	200	100	1.5	37,80	53,00
GDTD-C30 D	5,380	300	100	2	53,80	75,00
GDTD-C40 D	9,650	400	100	2	96,50	134,00
GDTD-C50 D	12,480	500	100	2	124,80	179,00
GDTD-C60 D	15,660	600	100	2	156,60	218,00

Kaplama : TS 914 EN ISO-1461 (BS-EN-ISO-1461) Sıcak Daldırma Galvaniz.  
Bu ürünler isteğe bağlı olarak Pregalvaniz ve CORTEN-A Saçdan İmal Edilebilir.

Coating : TS 914 EN ISO-1461 (BS-EN-ISO-1461) Hot Dip Galvanized  
These products can be produced from Pregalvanized or CORTEN-A Steel according to the requirements.

Talep üzerine tüm ürünler RODINO 50® malzemesi ile kaplanarak (max) 400°C ısıya, asit, tuz ve kum etkilerine karşı mukavemet sağlar.

In case of required all type of materials can be coated with RODINO 50® which will give on extra resistant at effect of 400°C heat, acid, salt and sand for the material.



## RADÜSLÜ DÖNÜŞ ELEMANLARI

### Flat Bends

### Угловые элементы

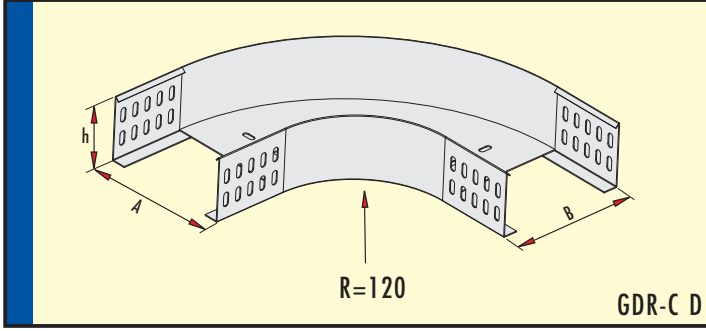

#### 90° Dönüş Elemanı 90° Flat Bend

угловые элементы 90°

Sipariş kodu Order code Код заявки	Ağırlık (Kg/ad.) Weight (Kg/unit) Вес (кг/шт)	A-B mm	h mm	e mm	Price list прайс-листу шт. у.е.	
					Pre-Galvanized Предв. Цинк-ия	Hot dip Galvanized гор.оцинк. HDZ
GDR-C10 D	1,720	105	100	1.5		20,64
GDR-C20 D	2,420	205	100	1.5		29,04
GDR-C30 D	4,400	305	100	2		52,80
GDR-C40 D	5,820	405	100	2		69,84
GDR-C50 D	7,490	505	100	2		89,88
GDR-C60 D	9,410	605	100	2		112,92

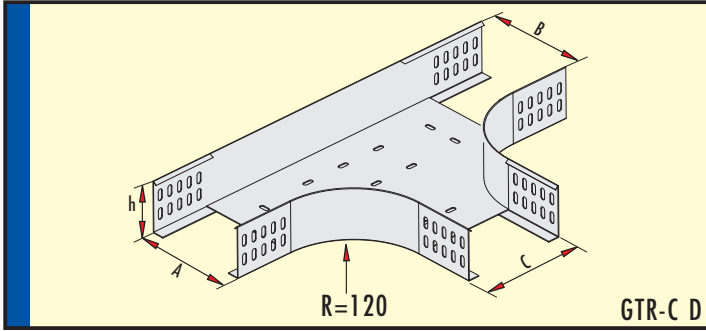

#### T Bağlantı Elemanı Tees "T"

«Т» образные соединительные элементы

Sipariş kodu Order code Код заявки	Ağırlık (Kg/ad.) Weight (Kg/unit) Вес (кг/шт)	A-B-C mm	h mm	e mm	Price list прайс-листу шт. у.е.	
					Pre-Galvanized Предв. Цинк-ия	Hot dip Galvanized гор.оцинк. HDZ
GTR-C10 D	2,530	105	100	1.5		30,36
GTR-C20 D	3,370	205	100	1.5		40,44
GTR-C30 D	5,920	305	100	2		71,04
GTR-C40 D	7,670	405	100	2		92,04
GTR-C50 D	9,730	505	100	2		116,76
GTR-C60 D	12,110	605	100	2		145,32

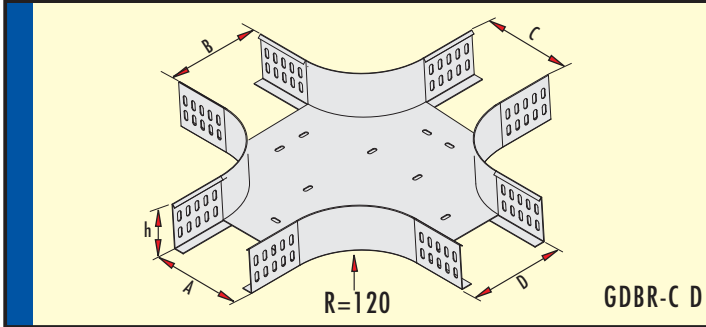

#### Dörtlü Bağlantı Elemanı Crossing Element

крестообразные соединительные элементы

Sipariş kodu Order code Код заявки	Ağırlık (Kg/ad.) Weight (Kg/unit) Вес (кг/шт)	A-B-C-D mm	h mm	e mm	Price list прайс-листу шт. у.е.	
					Pre-Galvanized Предв. Цинк-ия	Hot dip Galvanized гор.оцинк. HDZ
GDBR-C10 D	3,060	105	100	1.5		36,72
GDBR-C20 D	3,860	205	100	1.5		46,32
GDBR-C30 D	6,360	305	100	2		76,32
GDBR-C40 D	8,050	405	100	2		96,60
GDBR-C50 D	10,050	505	100	2		120,60
GDBR-C60 D	12,360	605	100	2		148,32

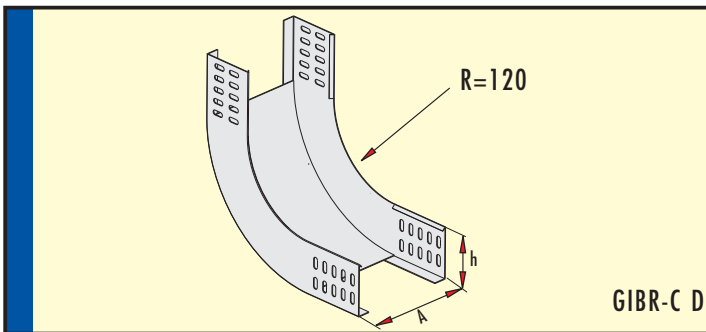

#### İç Bükü Elemanı Inside Vertical Bend

Внутри и снаружи Вертикальных Изгибов

Sipariş kodu Order code Код заявки	Ağırlık (Kg/ad.) Weight (Kg/unit) Вес (кг/шт)	A mm	h mm	e mm	Price list прайс-листу шт. у.е.	
					Pre-Galvanized Предв. Цинк-ия	Hot dip Galvanized гор.оцинк. HDZ
GIBR-C10 D	1,860	105	100	1.5		22,32
GIBR-C20 D	2,230	205	100	1.5		26,76
GIBR-C30 D	3,450	305	100	2		41,40
GIBR-C40 D	3,940	405	100	2		47,28
GIBR-C50 D	4,430	505	100	2		53,16
GIBR-C60 D	4,920	605	100	2		59,04

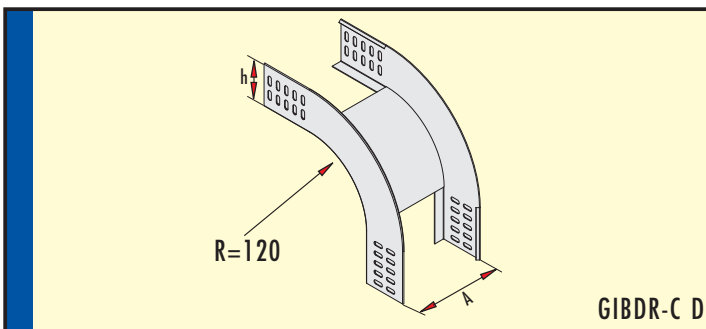

#### Dış Bükü Elemanı Outside Vertical Bend

Внутри и снаружи Вертикальных Изгибов

Sipariş kodu Order code Код заявки	Ağırlık (Kg/ad.) Weight (Kg/unit) Вес (кг/шт)	A mm	h mm	e mm	Price list прайс-листу шт. у.е.	
					Pre-Galvanized Предв. Цинк-ия	Hot dip Galvanized гор.оцинк. HDZ
GIBDR-C10 D	1,580	105	100	1.5		18,96
GIBDR-C20 D	1,750	205	100	1.5		21,00
GIBDR-C30 D	2,570	305	100	2		30,84
GIBDR-C40 D	2,800	405	100	2		33,60
GIBDR-C50 D	3,030	505	100	2		36,36
GIBDR-C60 D	3,260	605	100	2		39,12

Bağlantı elemanları isteğe bağlı olarak 150-300-450-600-900 Radüslü imal edilir.

Circles can be produced with ISO-300-450-600-900 Radius.



## REDÜKSİYON

## Reducer

## Редуктор

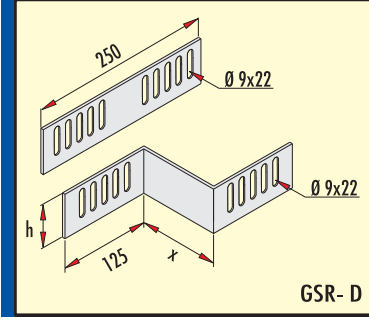

Redüksiyon X=100 mm'ye göredir.

Reducer

Редуктор

Sipariş kodu Order code Код заявки	Ağırlık (Kg/ad.) Weight (Kg/unit)	h mm	e mm	Price list прайс-листу шт. у.е.	
				Pre-Galvanized Предв. Цинк-ия	Hot dip Galvanized гор.оцинк. HDZ
GSR-40/100 D	0,400	40	2	3,20	4,80
GSR-50/100 D	0,500	50	2	4,00	6,00
GSR-60/100 D	0,600	60	2	4,80	7,20
GSR-70/100 D	0,700	70	2	5,60	8,40

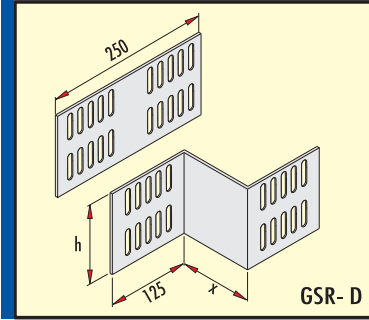
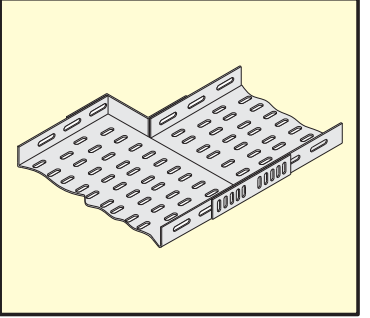

Redüksiyon X=100 mm'ye göredir.

Reducer

Редуктор

Sipariş kodu Order code Код заявки	Ağırlık (Kg/ad.) Weight (Kg/unit)	h mm	e mm	Price list прайс-листу шт. у.е.	
				Pre-Galvanized Предв. Цинк-ия	Hot dip Galvanized гор.оцинк. HDZ
GSR-100/100 D	1,000	100	2	8,00	12,00
GSR-150/100 D	1,500	150	2	12,00	18,00
GSR-200/100 D	2,000	200	2	16,00	24,00

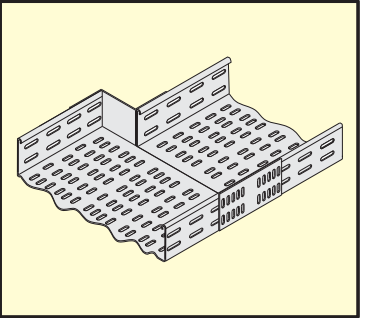

GSR redüksiyon siparişlerinde sağ veya sol redüksiyon olduğunu lütfen belirtiniz. For GSR reducer orders, please inform if you require left or right reducer.  
Для ваших заказов пожалуйста информируйте нас типу редуктора который является правым типом или левым типом.

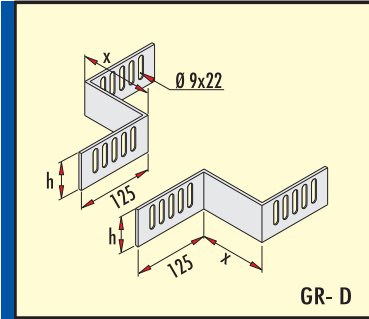

Redüksiyon X=100 mm'ye göredir.

Reducer

Редуктор

Sipariş kodu Order code Код заявки	Ağırlık (Kg/ad.) Weight (Kg/unit)	h mm	e mm	Price list прайс-листу шт. у.е.	
				Pre-Galvanized Предв. Цинк-ия	Hot dip Galvanized гор.оцинк. HDZ
GR-40/100 D	0,450	40	2	3,60	5,40
GR-50/100 D	0,600	50	2	4,80	7,20
GR-60/100 D	0,750	60	2	6,00	9,00
GR-70/100 D	0,850	70	2	6,80	10,20

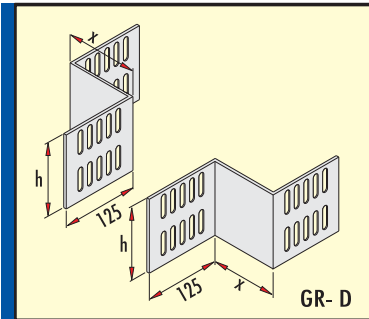
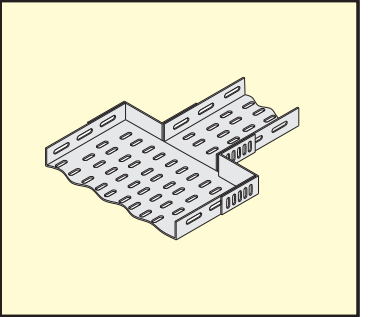

Redüksiyon X=100 mm'ye göredir.

Reducer

Редуктор

Sipariş kodu Order code Код заявки	Ağırlık (Kg/ad.) Weight (Kg/unit)	h mm	e mm	Price list прайс-листу шт. у.е.	
				Pre-Galvanized Предв. Цинк-ия	Hot dip Galvanized гор.оцинк. HDZ
GR-100/100 D	1,150	100	2	9,20	13,80
GR-150/100 D	1,650	150	2	13,20	19,80
GR-200/100 D	2,150	200	2	17,20	25,80

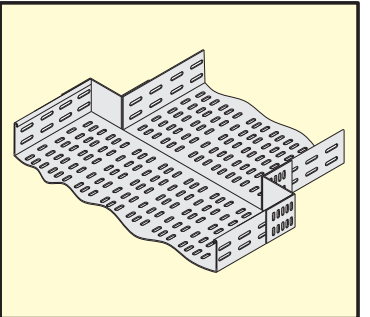

x ölçüsü değişkendir. Fiyat, verilen siparişe göre belirlenecektir. Sipariş Örneği: GR-70 x=100  
Dimension "x" variable. Price will be given due to the order Ordering example  
Размер «x» изменяется. Цены могут быть указаны в зависимости от заказа.

Kaplama : TS 914 EN ISO-1461 (BS-EN-ISO-1461) Sıcak Daldırma Galvaniz. Coating : TS 914 EN ISO-1461 (BS-EN-ISO-1461) Hot Dip Galvanized  
Bu Ürünler İsteğe Bağlı Olarak Pregalvaniz ve CORTEN-A Saçdan İmal Edilebilir. These products can be produced from Pregalvanized or CORTEN-A Steel according to the requirements.

Talep üzerine tüm ürünler RODINO 50® malzemesi ile kaplanarak (max) 400°C ısıya, asit, tuz ve kum etkilerine karşı mukavemet sağlar.  
In case of required all type of materials can be coated with RODINO 50® which will give on extra resistant at effect of 400°C heat, acid, salt and sand for the material.

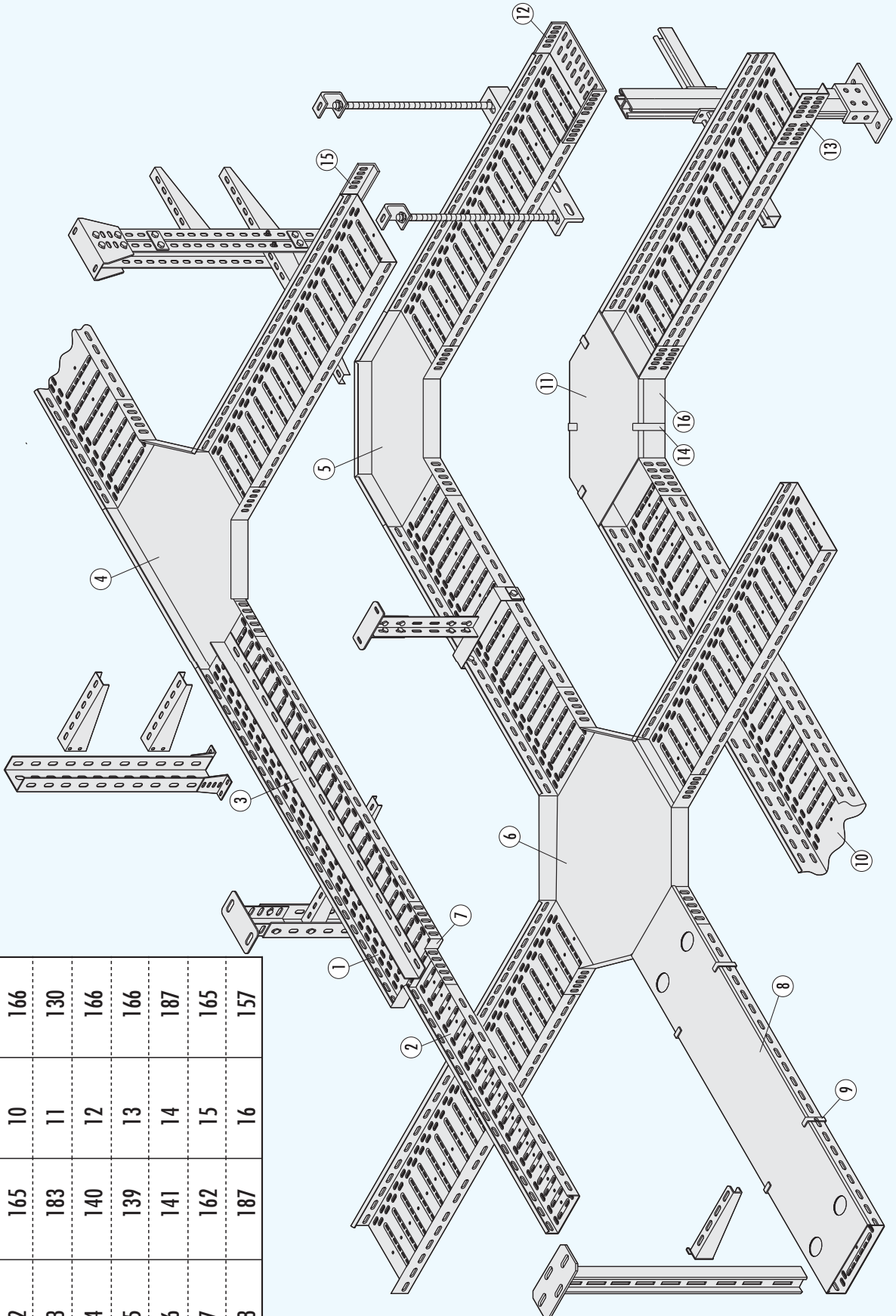

Parça No	Sayfa No	Parça No	Sayfa No
1	165	9	187
2	165	10	166
3	183	11	130
4	140	12	166
5	139	13	166
6	141	14	187
7	162	15	165
8	187	16	157

## MUKAVEMETLİ KABLO KANALLARI

### Strengthened Cable Trays

Прочностные кабельные лотки

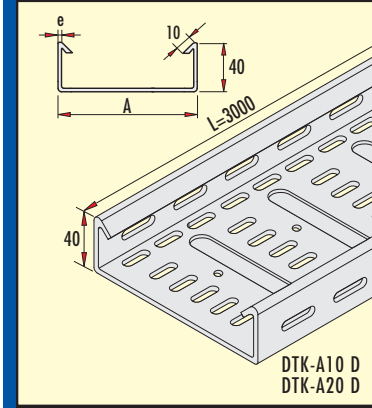

Mukavemetli Kablo Kanalları (h=40 mm) Strengthened Cable Trays (h=40 mm)						
Прочностные кабельные лотки						
Sipariş kodu Order code Код заявки	Ağırlık (Kg/mt.) Weight (Kg/mt) Вес (кг/м)	A mm	h mm	e mm	Price list прайс-лист М/у.е.	
					Pre-Galvanized Предв. Цинк-ия	Hot dip Galvanized гор.оцинк. HDZ
DTK-A10 D	1,600	100	40	1	8,00	14,40
DTK-A10-1	1,280	100	40	0,8	6,40	11,52
DTK-A20	2,400	200	40	1	12,00	21,60
DTK-A20-1	1,920	200	40	0,8	9,60	17,28
DTK-A30	3,200	300	40	1	16,00	28,80
DTK-A30-1	2,560	300	40	0,8	12,80	23,04
DTK-A30-2	4,800	300	40	1,5	24,00	43,20
DTK-A30-3	3,840	300	40	1,2	19,20	34,56
DTK-A40	4,000	400	40	1	20,00	36,00
DTK-A40-2	6,000	400	40	1,5	30,00	54,00
DTK-A40-3	4,800	400	40	1,2	24,00	43,20

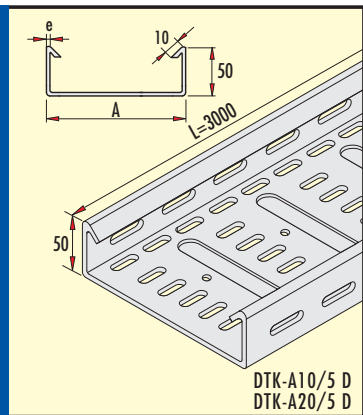
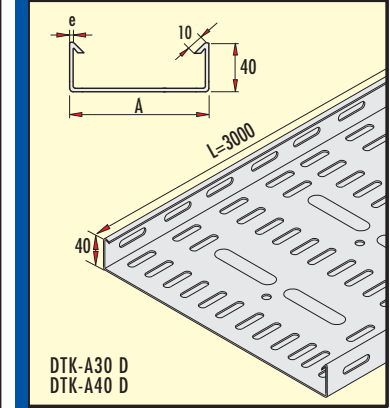

Mukavemetli Kablo Kanalları (h=50 mm) Strengthened Cable Trays (h=50 mm)						
Прочностные кабельные лотки						
Sipariş kodu Order code Код заявки	Ağırlık (Kg/mt.) Weight (Kg/mt) Вес (кг/м)	A mm	h mm	e mm	Price list прайс-лист М/у.е.	
					Pre-Galvanized Предв. Цинк-ия	Hot dip Galvanized гор.оцинк. HDZ
DTK-A10 /5 D	1,750	100	50	1	8,75	15,75
DTK-A10-1 /5	1,400	100	50	0,8	7,00	12,60
DTK-A20 /5	2,550	200	50	1	12,75	22,95
DTK-A20-1 /5	2,050	200	50	0,8	10,25	18,45
DTK-A30 /5	3,350	300	50	1	16,75	30,15
DTK-A30-1 /5	2,680	300	50	0,8	13,40	24,12
DTK-A30-2 /5	5,050	300	50	1,5	25,25	45,45
DTK-A30-3 /5	4,050	300	50	1,2	20,25	36,45
DTK-A40 /5	4,150	400	50	1	20,75	37,35
DTK-A40-2 /5	6,250	400	50	1,5	31,25	56,25
DTK-A40-3 /5	5,000	400	50	1,2	25,00	45,00

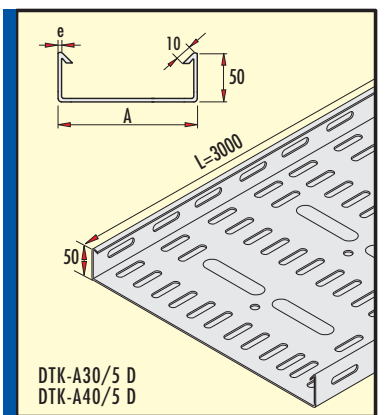

Kaplama : TS 914 EN ISO-1461 (BS-EN-ISO-1461) Sıcak Daldırma Galvaniz.  
Bu Ürünler İsteğe Bağlı Olarak Pregalvaniz ve CORTEN-A Saçdan İmal Edilebilir.

Coating : TS 914 EN ISO-1461 (BS-EN-ISO-1461) Hot Dip Galvanized  
These products can be produced from Pregalvanized or CORTEN-A Steel according to the requirements.

Talep üzerine tüm ürünler RODINO 50® malzemesi ile kaplanarak (max) 400°C ısıya, asit, tuz ve kum etkilerine karşı mukavemet sağlar.  
In case of required all type of materials can be coated with RODINO 50® which will give on extra resistant at effect of 400°C heat, acid, salt and sand for the material.



## MUKAVEMETLİ KABLO KANALLARI Strengthened Cable Trays

Прочностные кабельные лотки

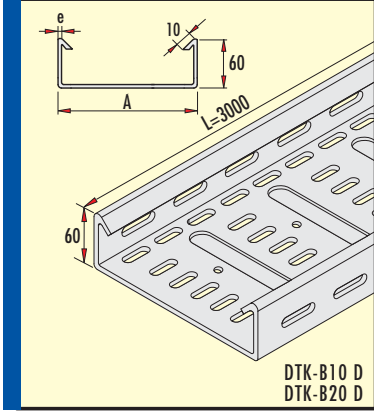

Mukavemetli Kablo Kanalları (h=60 mm) Strengthened Cable Trays (h=60 mm) Прочностные кабельные лотки						
Sipariş kodu Order code Код заявки	Ağırlık (Kg/mt.) Weight (Kg/mt) Вес (кг/м)	A mm	h mm	e mm	Price list прайс-лист М/у.е.	
					Pre-Galvanized Предв. Цинк-ия	Hot dip Galvanized гор.оцинк. HDZ
DTK-B10 D	1,900	100	60	1	9,50	17,10
DTK-B10-1	1,520	100	60	0,8	7,60	13,68
DTK-B20	2,700	200	60	1	13,50	24,30
DTK-B20-1	2,160	200	60	0,8	10,80	19,44
DTK-B30	3,500	300	60	1	17,50	31,50
DTK-B30-1	2,800	300	60	0,8	14,00	25,20
DTK-B30-2	5,250	300	60	1,5	26,25	47,25
DTK-B30-3	4,200	300	60	1,2	21,00	37,80
DTK-B40	4,300	400	60	1	21,50	38,70
DTK-B40-2	6,450	400	60	1,5	32,25	58,05
DTK-B40-3	5,160	400	60	1,2	25,80	46,44

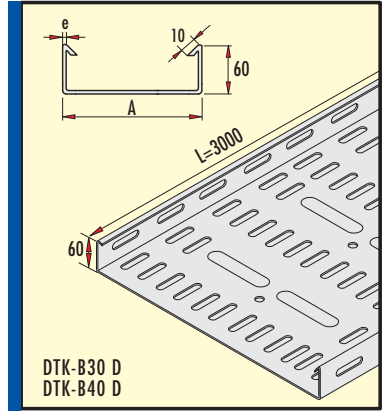

## Cıvatasız Ek Parçası Without Screw Jointing Piece Соединительные элементы

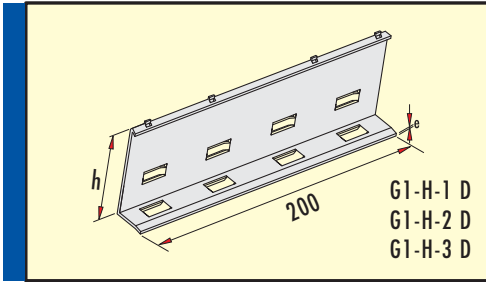

Cıvatasız Ek Parçası Without Screw Jointing Piece Соединительные элементы					
Sipariş kodu Order code Код заявки	Ağırlık (Kg/ad.) Weight (Kg/unit) Вес (кг/шт)	h mm	e mm	Price list прайс-лист шт/у.е.	
				Pre-Galvanized Предв. Цинк-ия	Hot dip Galvanized гор.оцинк. HDZ
G1-H-1 D	0.109	38	1	1,09	1,52
G1-H-2 D	0.128	48	1	1,28	1,80
G1-H-3 D	0.146	58	1	1,46	2,05

Kaplama : TS 914 EN ISO-1461 (BS-EN-ISO-1461) Sıcak Daldırma Galvaniz.  
Bu ürünler isteğe Bağlı Olarak Pregalvaniz ve CORTEN-A Saçdan İmal Edilebilir.

Coating : TS 914 EN ISO-1461 (BS-EN-ISO-1461) Hot Dip Galvanized  
These products can be produced from Pregalvanized or CORTEN-A Steel according to the requirements.

Talep üzerine tüm ürünler RODINO 50® malzemesi ile kaplanarak (max) 400°C ısıya, asit, tuz ve kum etkilerine karşı mukavemet sağlar.  
In case of required all type of materials can be coated with RODINO 50® which will give an extra resistant at effect of 400°C heat, acid, salt and sand for the material.

MUKAVEMETLİ KABLO KANALLARI

Strengthened Cable Trays

Прочностные кабельные лотки

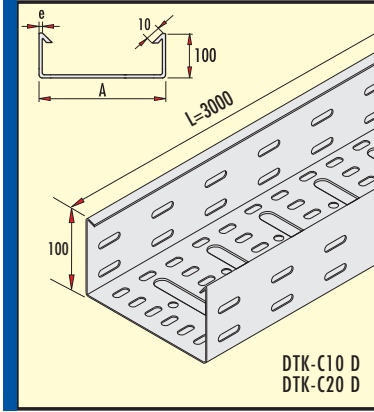

Mukavemetli Kablo Kanalları (h=100 mm)  
Strengthened Cable Trays (h=100 mm)

Прочностные кабельные лотки

Sipariş kodu Order code Код заявки	Ağırlık (Kg/mt.) Weight (Kg/mt) Вес (кг/м)	A mm	h mm	e mm	Price list прайс-лист м/у.е.	
					Pre-Galvanized Предв. Цинк-ия	Hot dip Galvanized гор.оцинк. HDZ
DTK-C10 D	2.550	100	100	1	12,75	23,00
DTK-C20 D	3.300	200	100	1	16,50	29,70
DTK-C30 D	4.100	300	100	1	20,50	36,90
DTK-C30-2 D	6.150	300	100	1.5	30,75	55,35
DTK-C40 D	4.900	400	100	1	24,50	44,10
DTK-C40-2 D	7.350	400	100	1.5	36,75	66,15

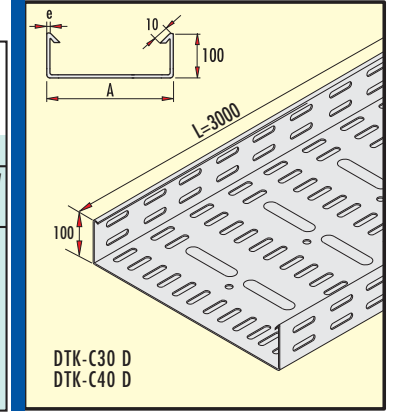

EK PARÇASI

Jointing Piece

Соединительные элементы

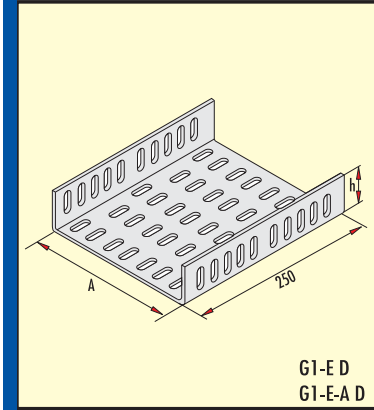

Ek Parçası Jointing Piece Соединительные элементы

Sipariş kodu Order code Код заявки	Ağırlık (Kg/ad.) Weight (Kg/unit) Вес (кг/шт)	A mm	h mm	e mm	Price list прайс-лист шт/у.е.	
					Pre-Galvanized Предв. Цинк-ия	Hot dip Galvanized гор.оцинк. HDZ
G1-E-10 D	0,550	102	40	1.5	4,40	6,60
G1-E-20 D	0,880	202	40	1.5	7,04	10,56
G1-E-30 D	1,100	302	40	1.5	8,80	13,20
G1-E-40 D	1,350	402	40	1.5	10,80	16,20
G1-E 10/5 D	0,610	102	50	1,5	4,88	7,32
G1-E 20/5 D	0,940	202	50	1,5	7,52	11,28
G1-E 30/5 D	1,160	302	50	1,5	9,28	13,92
G1-E 40/5 D	1,140	402	50	1,5	11,20	16,80
G1-E-A10 D	0,650	102	60	1,5	5,20	7,80
G1-E-A20 D	0,090	202	60	1,5	7,20	10,80
G1-E-A30 D	1,200	302	60	1,5	9,60	14,40
G1-E-A40 D	1,500	402	60	1,5	12,00	18,00
G1-E-B10 D	0,850	102	100	1,5	6,80	10,20
G1-E-B20 D	1,200	202	100	1,5	9,60	14,40
G1-E-B30 D	1,450	302	100	1,5	11,60	17,40
G1-E-B40 D	1,750	402	100	1,5	14,00	21,00

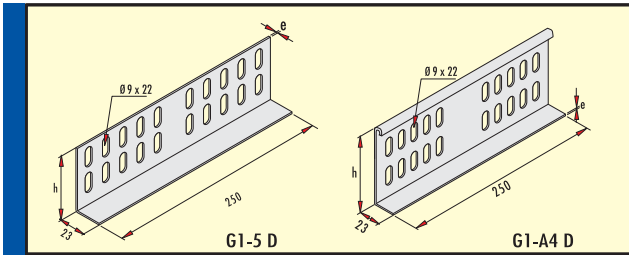
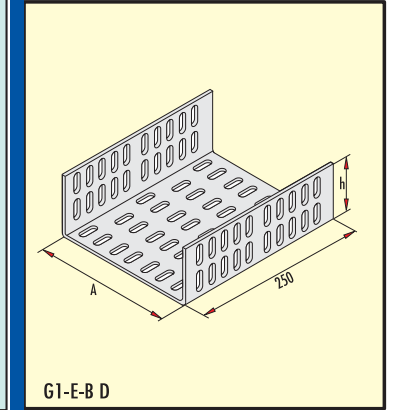

Sipariş kodu Order code Код заявки	Ağırlık (Kg/ad.) Weight (Kg/unit) Вес (кг/шт)	h mm	e mm	Price list прайс-лист шт/у.е.	
				Pre-Galvanized Предв. Цинк-ия	Hot dip Galvanized гор.оцинк. HDZ
G1-5 D	0,420	100	2	4,20	5,90
G1-A4 D	0,560	104	2	5,60	7,84

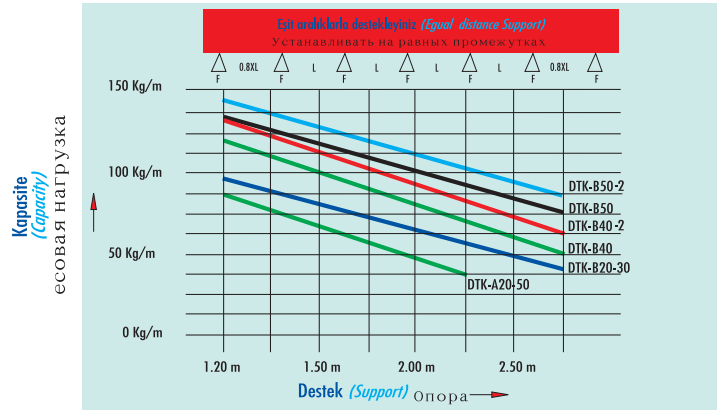

Kaplama : TS 914 EN ISO-1461 (BS-EN-ISO-1461) Sıcak Daldırma Galvaniz.  
Bu Ürünler İsteğe Bağlı Olarak Pregalvaniz ve CORTEN-A Saçdan İmal Edilebilir.

Coating : TS 914 EN ISO-1461 (BS-EN-ISO-1461) Hot Dip Galvanized  
These products can be produced from Pregalvanized or CORTEN-A Steel according to the requirements.

Talep üzerine tüm ürünler RODINO 50® malzemesi ile kaplanarak (max) 400°C ısıya, asit, tuz ve kum etkilerine karşı mukavemet sağlar.

In case of required all type of materials can be coated with RODINO 50® which will give on extra resistant at effect of 400°C heat, acid, salt and sand for the material.

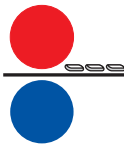

CIVATASIZ EK PARÇASI MONTAJ ÖRNEĞİ *Without Screw Jointing Piece Mounting Sample*

Примеры монтажа

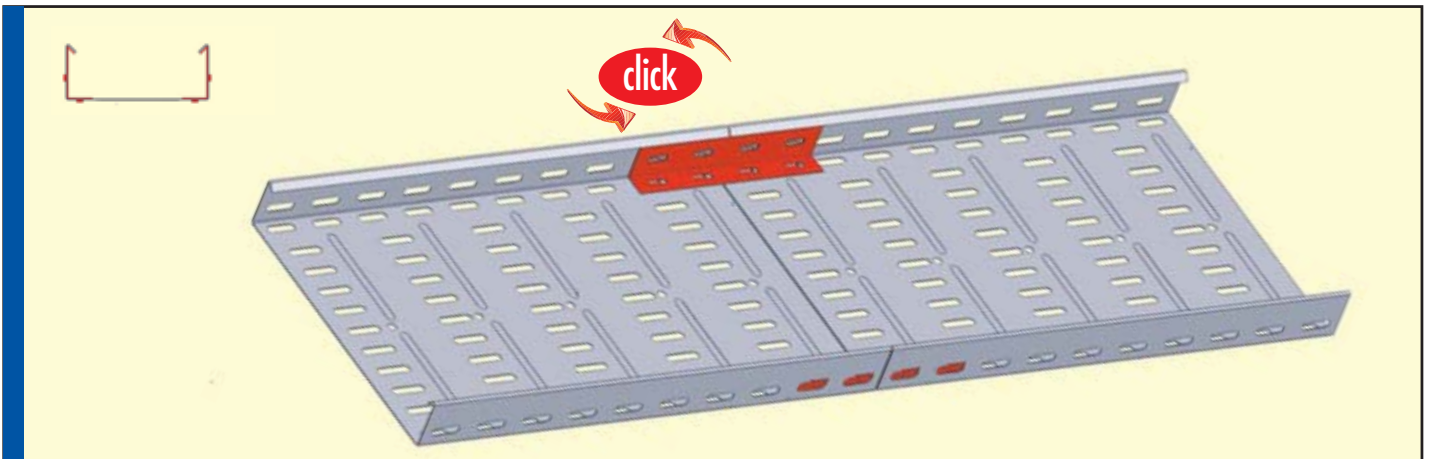
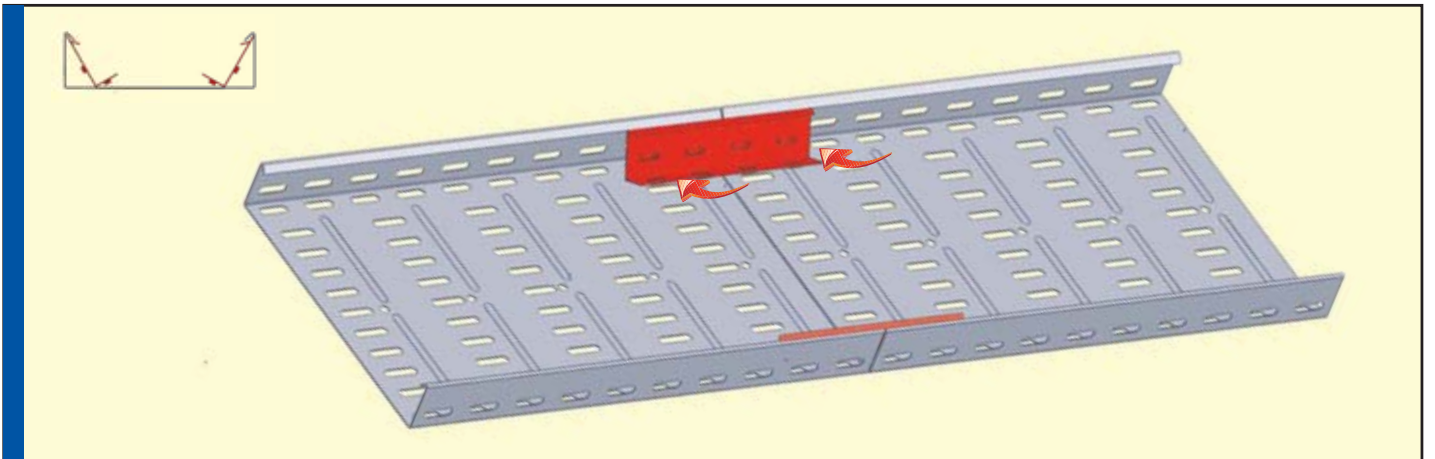
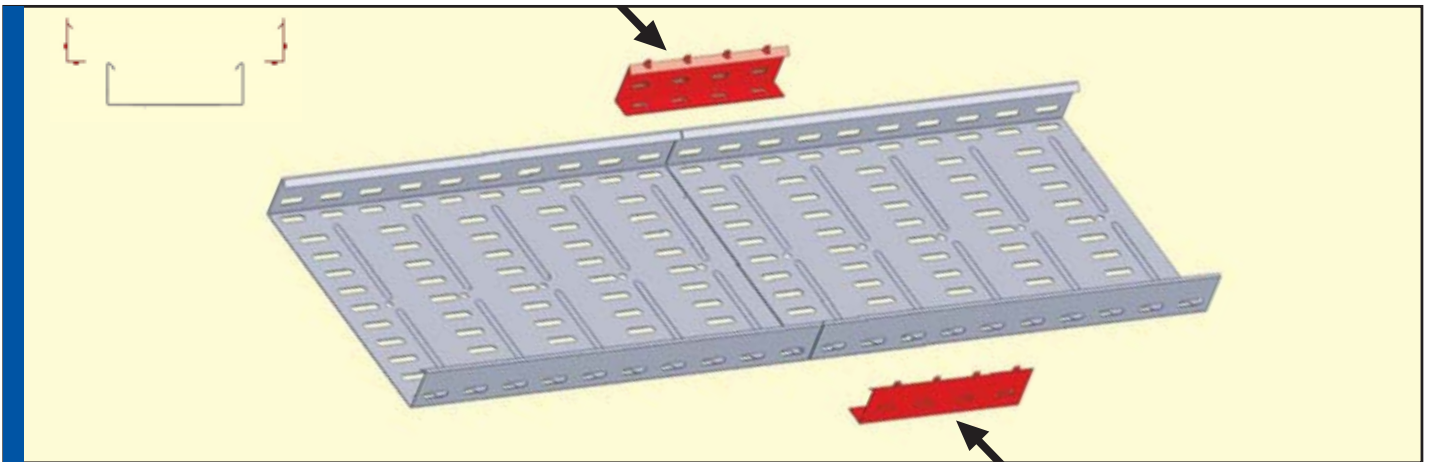
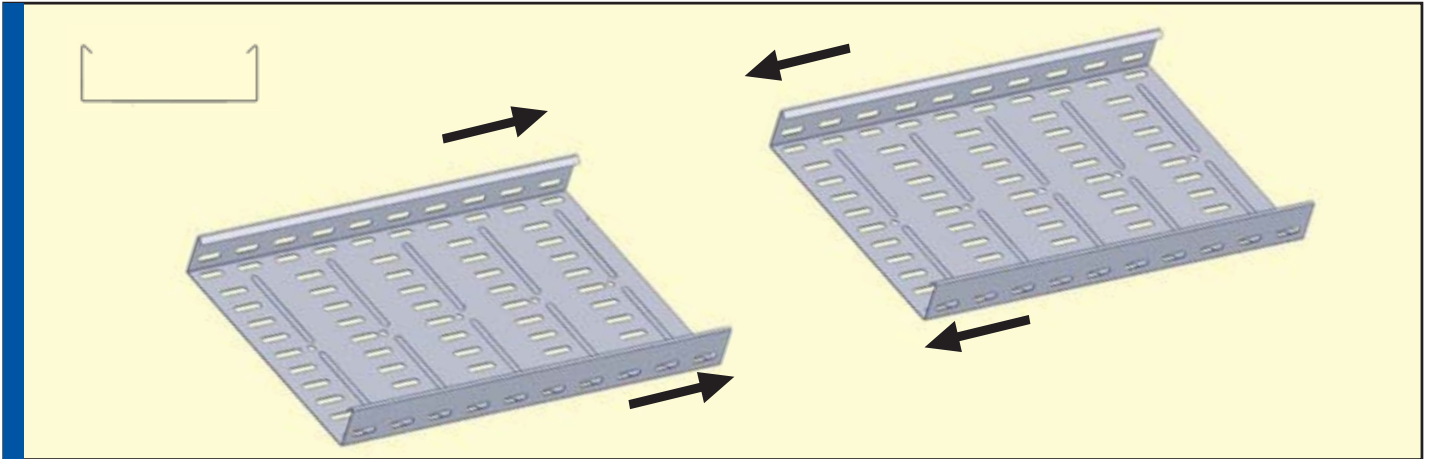

## GEMİ TİPİ (PARKE) KABLO KANALLARI

### Marine Type Cable Trays

### Кабельные лотки корабельного типа (паркет)

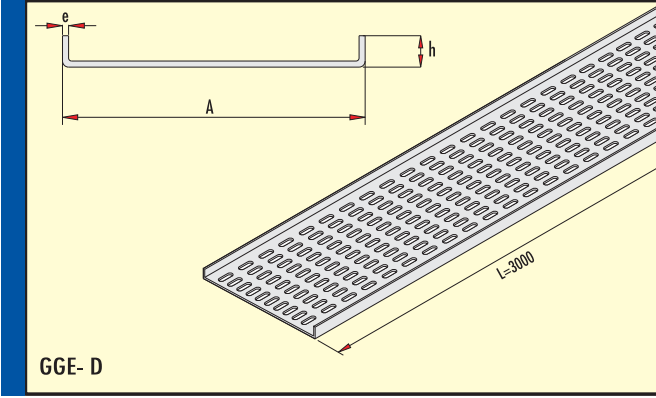

### Gemi Tipi (Parke) Kablo Kanalları (h=15 mm)

#### Marine Type Cable Trays (h=15 mm)

Кабельные лотки корабельного типа (паркет)

Sipariş kodu Order code Код заявки	Ağırlık (Kg/mt.) Weight (Kg/mt) Вес (кг/м)	A mm	h mm	e mm	Price list прайс-лист м/у.е.	
					Pre-Galvanized Предв. Цинк-ия	Hot dip Galvanized гор.оцинк. HDZ
GGE-5 D	0,550	50	15	1	2,75	5,00
GGE-10 D	0,900	100	15	1	4,50	8,00
GGE-20 D	1,500	200	15	1	7,50	13,50
GGE-30 D	3,250	300	15	1.5	16,25	29,00
GGE-40 D	4,550	400	15	1.5	22,75	40,50
GGE-50 D	5,700	500	15	1.5	28,50	51,00
GGE-60 D	6,750	600	15	1.5	33,75	61,00

## ARMATÜR TİPİ KABLO KANALLARI

### Lighting Fixture Type Cable Trays

### Кабельные лотки арматурного типа

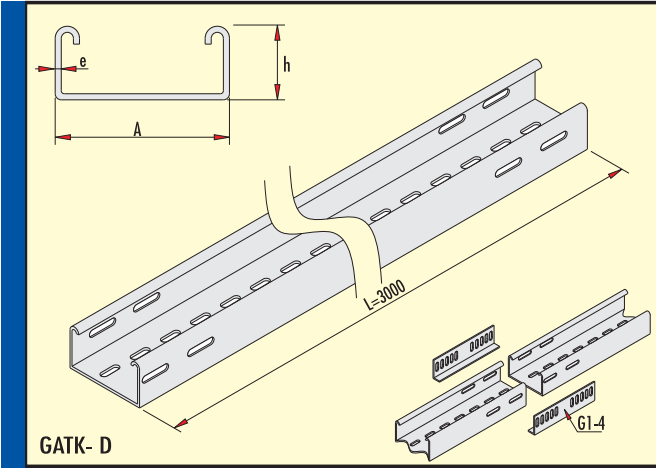

### Armatür Tipi Kablo Kanalları (h=60 mm)

#### Lighting Fixture Type Cable Trays (h=60 mm)

Кабельные лотки арматурного типа

Sipariş kodu Order code Код заявки	Ağırlık (Kg/mt.) Weight (Kg/mt) Вес (кг/м)	A mm	h mm	e mm	Price list прайс-лист м/у.е.	
					Pre-Galvanized Предв. Цинк-ия	Hot dip Galvanized гор.оцинк. HDZ
GATK-7 D	1,800	70	60	1	9,00	16,00
GATK-10 D	2,050	100	60	1	10,00	18,00
GATK-20 D	2,900	200	60	1	14,50	26,00

Armatür tipi kablo kanallarında diğer kablo kanallarının aksesuarları kullanılır.

The accessories used in lighting fixture type cable trays are similar with other types of cable trays.

Принадлежности, используемые в подносах кабеля типа осветительной арматуры подобны с другими типами кабельных подносов.

## EK PARÇASI Jointing Piece

### Соединительные элементы

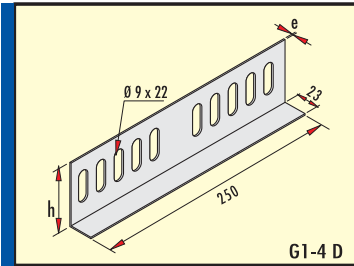

### Ek Parçası (h=60 mm) Jointing Piece (h=60 mm)

Соединительные элементы

Sipariş kodu Order code Код заявки	Ağırlık (Kg/ad.) Weight (Kg/unit) Вес (кг/шт)	h mm	e mm	Price list прайс-лист шт/у.е.	
				Pre-Galvanized Предв. Цинк-ия	Hot dip Galvanized гор.оцинк. HDZ
G1-4 D	0,270	60	2	2,70	3,80

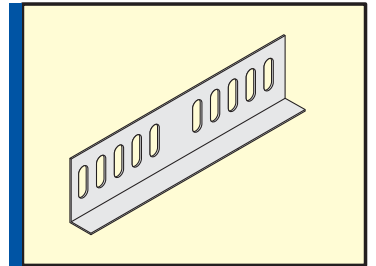

## TIJLİ ARMATÜR ASKI ELEMANI

### Lighting Fixture Element-used with threaded Rods

### Опоры со шпилькой для светильники

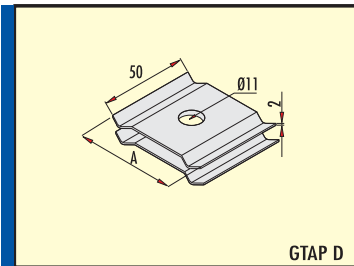

### Tijli Armatür Askı Elemanı

#### Lighting Fixture Element-used with threaded Rods

Опоры со шпилькой для светильники

Sipariş kodu Order code Код заявки	Ağırlık (Kg/ad.) Weight (Kg/unit) Вес (кг/шт)	A mm	e mm	Price list прайс-лист шт/у.е.	
				Pre-Galvanized Предв. Цинк-ия	Hot dip Galvanized гор.оцинк. HDZ
GTAP - 7 D	0.100	70	2	1.00	1.40
GTAP - 10 D	0.160	100	2	1.60	2.24
GTAP - 20 D	0.350	200	2	3.50	4.90

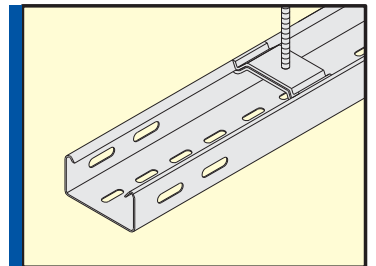

Kaplama : TS 914 EN ISO-1461 (BS-EN-ISO-1461) Sıcak Daldırma Galvaniz.

Bu Ürünler İsteğe Bağlı Olarak Pregalvaniz ve CORTEN-A Sacdan İmal Edilebilir.

Coating : TS 914 EN ISO-1461 (BS-EN-ISO-1461) Hot Dip Galvanized

These products can be produced from Pregalvanized or CORTEN-A Steel according to the requirements.

Talep üzerine tüm ürünler RODINO 50® malzemesi ile kaplanarak (max) 400°C ısıya, asit, tuz ve kum etkilerine karşı mukavemet sağlar.

In case of required all type of materials can be coated with RODINO 50® which will give on extra resistant at effect of 400°C heat, acid, salt and sand for the material.



ARMATÜR TİPİ KABLO KANALLARI

Lighting Fixture Type Cable Tray

Кабельные лотки арматурного типа

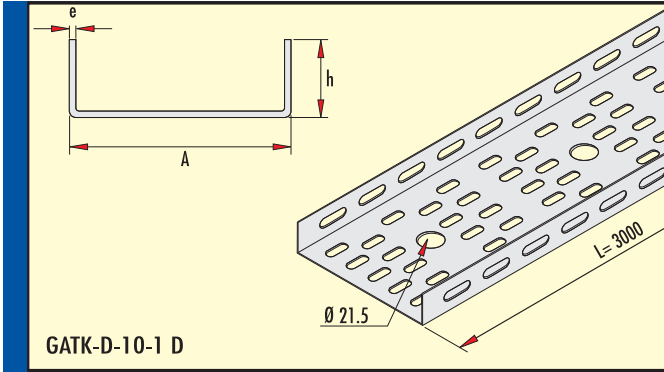

Armatür Tipi Kablo Kanalı  
Lighting Fixture Type Cable Tray

Кабельные лотки арматурного типа

Sipariş kodu Order code Код заявки	Ağırlık (Kg/mt.) Weight (Kg/mt) Вес (кг/м)	A mm	h mm	e mm	Price list прайс-лист м/у.е.	
					Pre-Galvanized Предв. Цинк-ия	Hot dip Galvanized гор.оцинк. HDZ
GATK-D-10-1 D	1,350	100	40	1	6,75	12,00
GATK-D-10-2 D	1,900	100	40	1.5	9,50	17,00
GATK-E-10-1 D	1,400	100	50	1	7,00	12,60
GATK-E-10-2 D	2,100	100	50	1.5	10,50	19,00

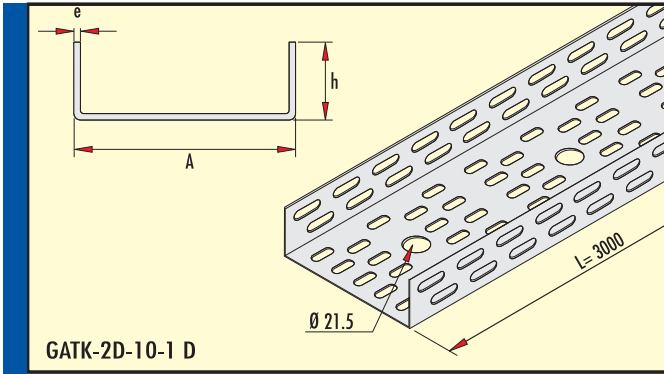

Armatür Tipi Kablo Kanalı  
Lighting Fixture Type Cable Tray

Кабельные лотки арматурного типа

Sipariş kodu Order code Код заявки	Ağırlık (Kg/mt.) Weight (Kg/mt) Вес (кг/м)	A mm	h mm	e mm	Price list прайс-лист м/у.е.	
					Pre-Galvanized Предв. Цинк-ия	Hot dip Galvanized гор.оцинк. HDZ
GATK-2D-10-1 D	1,400	100	50	1	7,00	12,60
GATK-2D-10-2 D	2,100	100	50	1.5	10,50	19,00
GATK-2E-10-1 D	1,550	100	50	1	7,75	14,00
GATK-2E-10-2 D	2,300	100	50	1.5	11,50	20,70

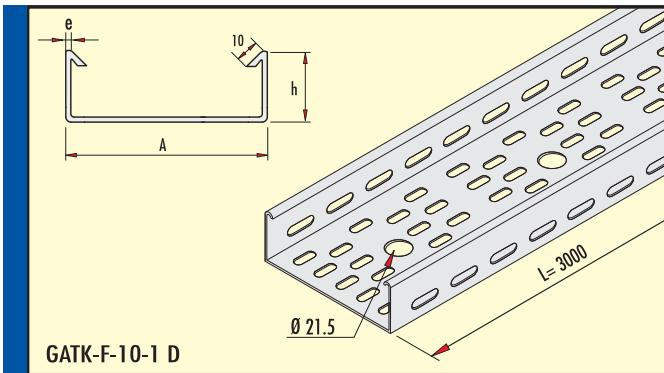

Armatür Tipi Kablo Kanalı  
Lighting Fixture Type Cable Tray

Кабельные лотки арматурного типа

Sipariş kodu Order code Код заявки	Ağırlık (Kg/mt.) Weight (Kg/mt) Вес (кг/м)	A mm	h mm	e mm	Price list прайс-лист м/у.е.	
					Pre-Galvanized Предв. Цинк-ия	Hot dip Galvanized гор.оцинк. HDZ
GATK-F-10-1 D	1,400	100	40	1	7,00	12,60
GATK-F-10-2 D	2,100	100	40	1.5	10,50	19,00
GATK-G-10-1 D	1,550	100	50	1	7,75	14,00
GATK-G-10-2 D	2,300	100	50	1.5	11,50	20,70
GATK-H-10-1 D	1,700	100	60	1	8,50	15,30
GATK-H-10-2 D	2,600	100	60	1.5	13,00	23,40

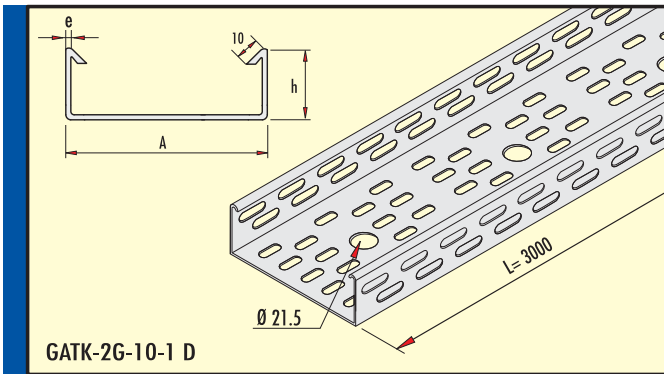

Armatür Tipi Kablo Kanalı  
Lighting Fixture Type Cable Tray

Кабельные лотки арматурного типа

Sipariş kodu Order code Код заявки	Ağırlık (Kg/mt.) Weight (Kg/mt) Вес (кг/м)	A mm	h mm	e mm	Price list прайс-лист м/у.е.	
					Pre-Galvanized Предв. Цинк-ия	Hot dip Galvanized гор.оцинк. HDZ
GATK-2G-10-1 D	1,550	100	50	1	7,75	14,00
GATK-2G-10-2 D	2,300	100	50	1.5	11,50	20,70
GATK-2H-10-1 D	1,700	100	60	1	8,50	15,30
GATK-2H-10-2 D	2,600	100	60	1.5	13,00	23,40

Armatür tipi kablo kanallarında diğer kablo kanallarının aksesuarları kullanılır. The accessories used in lighting fixture type cable trays are similar with other types of cable trays.  
Принадлежности, используемые в подносах кабеля типа осветительной арматуры подобны с другими типами кабельных подносов.

Kaplama : TS 914 EN ISO-1461 (BS-EN-ISO-1461) Sıcak Daldırma Galvaniz. Coating : TS 914 EN ISO-1461 (BS-EN-ISO-1461) Hot Dip Galvanized

Bu Ürünler İsteğe Bağlı Olarak Pregalvaniz ve CORTEN-A Saçdan İmal Edilebilir. These products can be produced from Pregalvanized or CORTEN-A Steel according to the requirements.

Talep üzerine tüm ürünler RODINO 50® malzemesi ile kaplanarak (max) 400°C ısıya, asit, tuz ve kum etkilerine karşı mukavemet sağlar.

In case of required all type of materials can be coated with RODINO 50® which will give on extra resistant at effect of 400°C heat, acid, salt and sand for the material.

## GEÇMELİ KAPAKLI TİP KABLO KANALLARI

Кабельные лотки с выдвигающейся крышкой

## Cable Tray With Clamping Lid

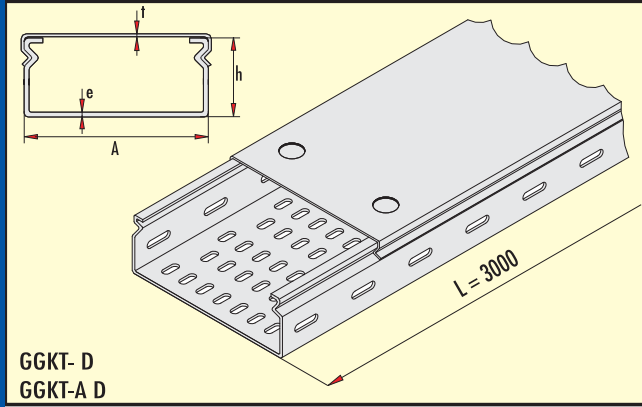

GGKT- D  
GGKT-A D

h=60 Kanal için G1-2G Ek parçası kullanılır  
G1-2G joint piece is used for h=60 Cable Trays

### Geçmeli Kapaklı Tip Kablo Kanalı

#### Cable Tray With Clamping Lid

Кабельные лотки с выдвигающейся крышкой

Sipariş kodu Order code Код заявки	Ağırlık (Kg/mt.) Weight (Kg/mt) Вес (кг/м)	A mm	h mm	e mm	t mm	Price list прайс-лист м/у.е.	
						Pre-Galvanized Предв. Цинк-ия	Hot dip Galvanized гор.оцинк. HDZ
GGKT -10 D	3,400	100	60	1.5	1	17,00	30,00
GGKT -20 D	5,670	200	60	1.5	1	28,35	51,00
GGKT -30 D	10,520	300	60	2	1	52,60	95,00
GGKT -40 D	13,000	400	60	2	1.5	65,00	117,00
GGKT -50 D	15,320	500	60	2	1.5	77,00	138,00
GGKT -60 D	17,800	600	60	2	1.5	89,00	160,00
GGKT -A10 D	3,900	100	70	1.5	1	19,50	35,00
GGKT -A20 D	5,850	200	70	1.5	1	29,00	53,00
GGKT -A30 D	11,200	300	70	2	1	56,00	100,00
GGKT -A40 D	13,500	400	70	2	1.5	67,50	121,00
GGKT -A50 D	15,750	500	70	2	1.5	79,00	141,00
GGKT -A60 D	18,000	600	70	2	1.5	90,00	162,00

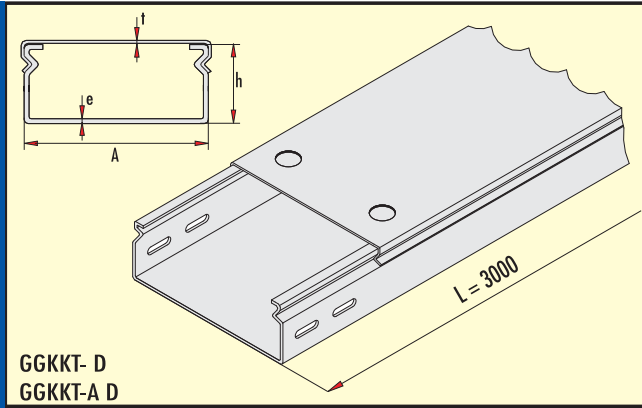

GGKKT- D  
GGKKT-A D

h=70 Kanal için G1-3G Ek parçası kullanılır  
G1-3G joint piece is used for h=70 Cable Trays

### Geçmeli Kapaklı Deliksiz Tip Kablo Kanalı

#### Cable Tray With Non Perforated Clamping Lid

Неперфорированный Кабельный Лоток с Выдвигающийся Крышкой

Sipariş kodu Order code Код заявки	Ağırlık (Kg/mt.) Weight (Kg/mt) Вес (кг/м)	A mm	h mm	e mm	t mm	Price list прайс-лист м/у.е.	
						Pre-Galvanized Предв. Цинк-ия	Hot dip Galvanized гор.оцинк. HDZ
GGKKT-10 D	3,850	100	60	1.5	1	19,00	35,00
GGKKT-20 D	6,400	200	60	1.5	1	32,00	57,00
GGKKT-30 D	11,800	300	60	2	1	59,00	106,00
GGKKT-40 D	14,600	400	60	2	1.5	73,00	131,00
GGKKT-50 D	17,300	500	60	2	1.5	86,00	155,00
GGKKT-60 D	20,100	600	60	2	1.5	100,00	180,00
GGKKT-A10 D	4,400	100	70	1.5	1	22,00	39,00
GGKKT-A20 D	6,600	200	70	1.5	1	30,00	59,00
GGKKT-A30 D	12,600	300	70	2	1	63,00	113,00
GGKKT-A40 D	15,250	400	70	2	1.5	76,00	137,00
GGKKT-A50 D	17,750	500	70	2	1.5	89,00	159,00
GGKKT-A60 D	20,300	600	70	2	1.5	101,50	182,00

## EK PARÇASI

## Jointing Piece

Соединительные элементы

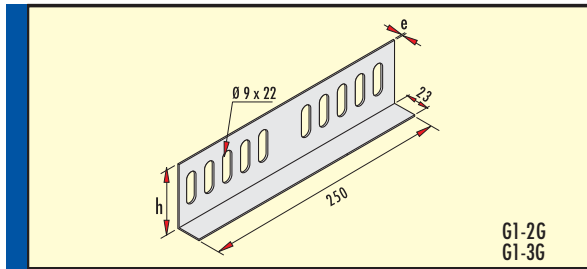

G1-2G  
G1-3G

### Ek Parçası Jointing Piece

Соединительные элементы

Sipariş kodu Order code Код заявки	Ağırlık (Kg/ad.) Weight (Kg/unit) Вес (кг/шт)	h mm	e mm	Price list прайс-лист шт/у.е.	
				Pre-Galvanized Предв. Цинк-ия	Hot dip Galvanized гор.оцинк. HDZ
G1-2G	0,200	40	2	2,00	2,80
G1-3G	0,240	50	2	2,40	3,36

### Eşit aralıklarla destekleyiniz (Equal distance Support)

Устанавливать на равных промежутках

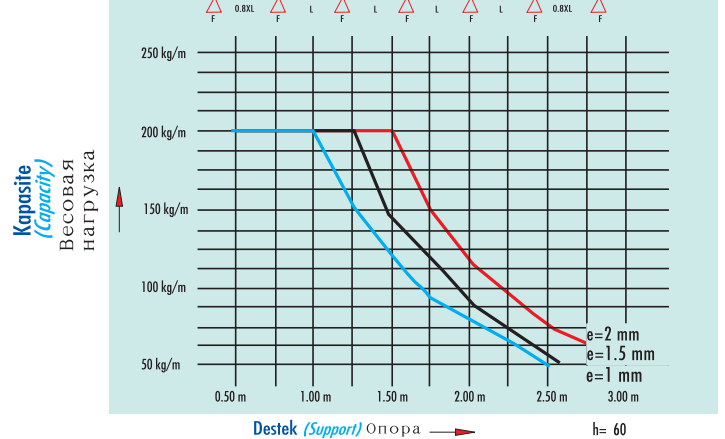

Kaplama : TS 914 EN ISO-1461 (BS-EN-ISO-1461) Sıcak Daldırma Galvaniz. Coating : TS 914 EN ISO-1461 (BS-EN-ISO-1461) Hot Dip Galvanized

Bu Ürünler İsteğe Bağlı Olarak Pregalvaniz ve CORTEN-A Saçdan İmal Edilebilir. These products can be produced from Pregalvanized or CORTEN-A Steel according to the requirements.

Talep üzerine tüm ürünler RODINO 50® malzemesi ile kaplanarak (max) 400°C ısıya, asit, tuz ve kum etkilerine karşı mukavemet sağlar.

In case of required all type of materials can be coated with RODINO 50® which will give on extra resistant at effect of 400°C heat, acid, salt and sand for the material.

## GEÇMELİ KAPAKLI TİP KABLO KANALLARI

Кабельные лотки с выдвигающейся крышкой

## Cable Tray With Clamping Lid

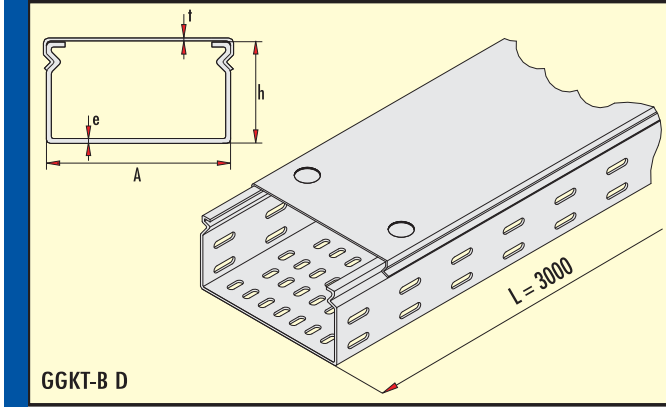

### Geçmeli Kapaklı Tip Kablo Kanalı

#### Cable Tray With Clamping Lid

Кабельные лотки с выдвигающейся крышкой

Sipariş kodu Order code Код заявки	Ağırlık (Kg/mt.) Weight (Kg/mt) Вес (кг/м)	A mm	h mm	e mm	t mm	Price list прайс-лист М/у.е.	
						Pre-Galvanized Предв. Цинк-ия	Hot dip Galvanized гор.оцинк. HDZ
GGKT-B10 D	4,200	100	100	1.5	1	21,00	38,00
GGKT-B20 D	6,400	200	100	1.5	1	32,00	58,00
GGKT-B30 D	12,150	300	100	2	1	61,00	109,00
GGKT-B40 D	14,400	400	100	2	1.5	72,00	129,00
GGKT-B50 D	16,700	500	100	2	1.5	83,00	150,00
GGKT-B60 D	19,300	600	100	2	1.5	96,00	174,00

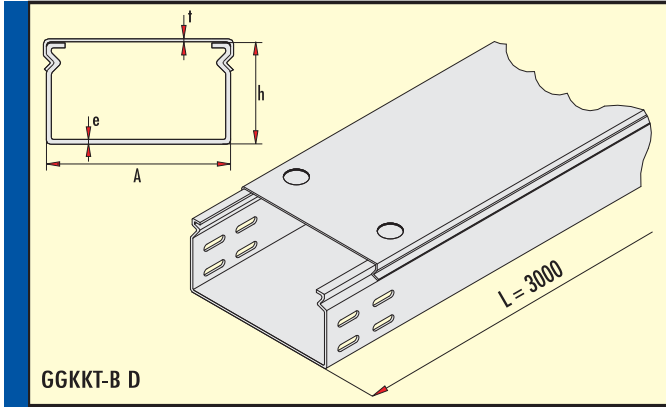

### Geçmeli Kapaklı Deliksiz Tip Kablo Kanalı

#### Cable Tray With Non Perforated Clamping Lid

Неперфорированный Кабельный Лоток с Выдвигающийся Крышкой

Sipariş kodu Order code Код заявки	Ağırlık (Kg/mt.) Weight (Kg/mt) Вес (кг/м)	A mm	h mm	e mm	t mm	Price list прайс-лист М/у.е.	
						Pre-Galvanized Предв. Цинк-ия	Hot dip Galvanized гор.оцинк. HDZ
GGKKT-B10 D	4,700	100	100	1.5	1	24,00	43,00
GGKKT-B20 D	7,200	200	100	1.5	1	36,00	65,00
GGKKT-B30 D	13,700	300	100	2	1	68,00	123,00
GGKKT-B40 D	16,250	400	100	2	1.5	81,00	146,00
GGKKT-B50 D	18,850	500	100	2	1.5	94,00	169,00
GGKKT-B60 D	21,800	600	100	2	1.5	109,00	196,00

## EK PARÇASI

## Jointing Piece

Соединительные элементы

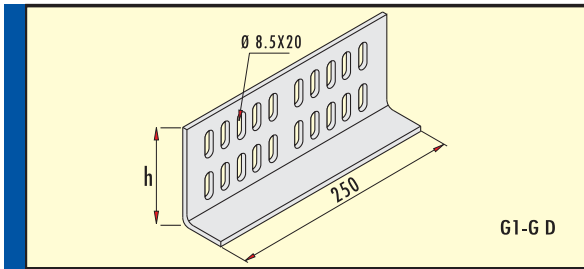

### Ek Parçası Jointing Piece

Соединительные элементы

Sipariş kodu Order code Код заявки	Ağırlık (Kg/ad.) Weight (Kg/unit) Вес (кг/шт)	h mm	e mm	Price list прайс-лист шт./у.е.	
				Pre-Galvanized Предв. Цинк-ия	Hot dip Galvanized гор.оцинк. HDZ
G1-4/80	0,330	80	2	3,30	4,65

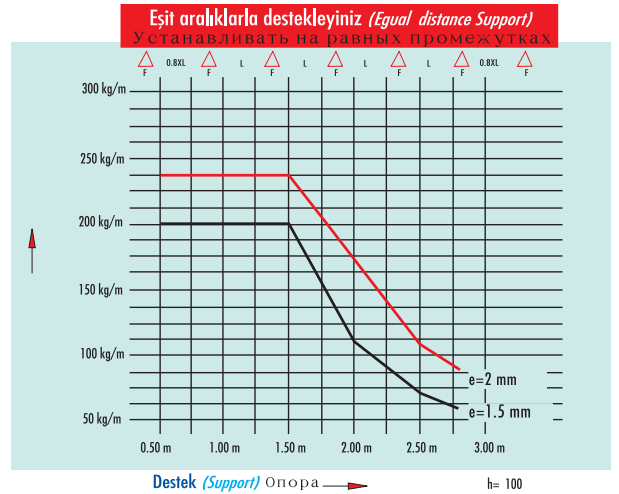

Kaplama : TS 914 EN ISO-1461 (BS-EN-ISO-1461) Sıcak Daldırma Galvaniz. Coating : TS 914 EN ISO-1461 (BS-EN-ISO-1461) Hot Dip Galvanized

Bu Ürünler İsteğe Bağlı Olarak Pregalvaniz ve CORTEN-A Saçdan İmal Edilebilir. These products can be produced from Pregalvanized or CORTEN-A Steel according to the requirements.

Talep üzerine tüm ürünler RODINO 50® malzemesi ile kaplanarak (max) 400°C ısıya, asit, tuz ve kum etkilerine karşı mukavemet sağlar.

In case of required all type of materials can be coated with RODINO 50® which will give on extra resistant at effect of 400°C heat, acid, salt and sand for the material.

GEÇMELİ KAPAKLI KABLO KANALI DÖNÜŞ ELEMANLARI

Bend Elements For Cable Trays With Clamping Lid

Угловые Элементы Кабельных Лотков с Выдвигающийся Крышкой

Geçmeli Kapaklı 90° Dönüş Elemanı 90° With Clamping Flat Bend Lid

Угловой Элемент с Выдвигающийся Крышкой на 90

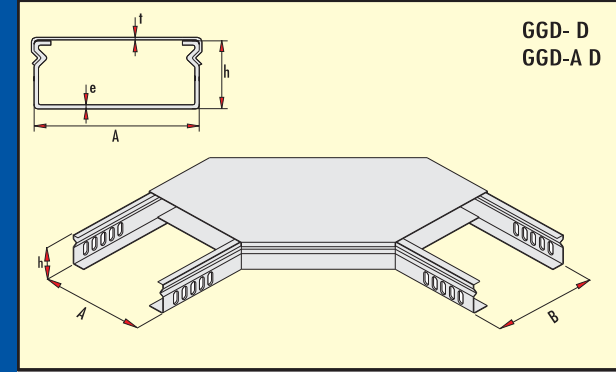

Sipariş kodu Order code Код заявки	Ağırlık (Kg/ad.) Weight (Kg/unit) Вес (кг / шт)	A-B mm	h mm	e mm	t mm	Price list прайс-лист шт /у.е.	
						Pre-Galvanized Предв. Цинк-ия	Hot dip Galvanized гор.оцинк. HDZ
GGD-10D	1,200	104	60	1.5	1	9,60	14,40
GGD-20D	2,470	204	60	1.5	1	19,76	29,64
GGD-30D	4,700	304	60	2	1	37,60	56,40
GGD-40D	9,120	404	60	2	1,5	72,96	109,44
GGD-50D	12,850	504	60	2	1,5	102,80	154,20
GGD-60D	17,350	604	60	2	1,5	138,80	208,20
GGD-A10D	1,400	104	70	1.5	1	11,20	16,80
GGD-A20D	2,650	204	70	1.5	1	21,20	31,80
GGD-A30D	5,100	304	70	2	1	40,80	61,20
GGD-A40D	9,500	404	70	2	1,5	76,00	114,00
GGD-A50D	13,300	504	70	2	1,5	106,40	159,60
GGD-A60D	17,850	604	70	2	1,5	142,80	214,20

Geçmeli Kapaklı 90° Dönüş Elemanı 90° With Clamping Flat Bend Lid

Угловой Элемент с Выдвигающийся Крышкой на 90

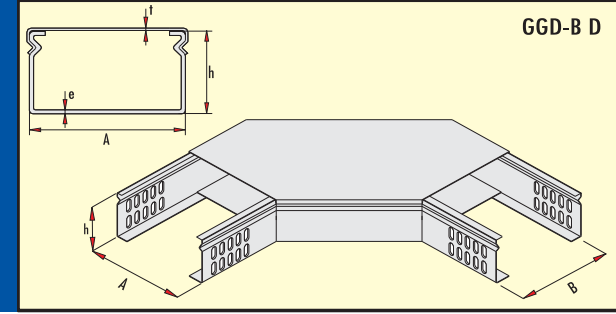

Sipariş kodu Order code Код заявки	Ağırlık (Kg/ad.) Weight (Kg/unit) Вес (кг / шт)	A-B mm	h mm	e mm	t mm	Price list прайс-лист шт /у.е.	
						Pre-Galvanized Предв. Цинк-ия	Hot dip Galvanized гор.оцинк. HDZ
GGD-B10D	1,700	104	100	1.5	1	13,60	20,40
GGD-B20D	2,900	204	100	1.5	1	23,20	34,80
GGD-B30D	5,400	304	100	2	1	43,20	64,80
GGD-B40D	9,950	404	100	2	1,5	79,60	119,40
GGD-B50D	13,750	504	100	2	1,5	110,00	165,00
GGD-B60D	18,400	604	100	2	1,5	147,20	220,80

Geçmeli Kapaklı "T" Bağlantı Elemanı Tee "T" With Clamping

T-образный Элемент с Выдвигающийся Крышкой

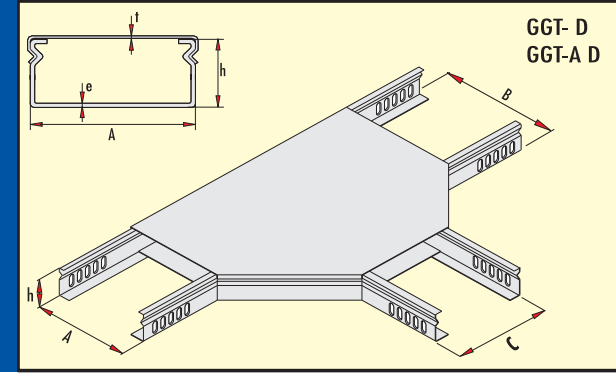

Sipariş kodu Order code Код заявки	Ağırlık (Kg/ad.) Weight (Kg/unit) Вес (кг / шт)	A-B-C mm	h mm	e mm	t mm	Price list прайс-лист шт /у.е.	
						Pre-Galvanized Предв. Цинк-ия	Hot dip Galvanized гор.оцинк. HDZ
GGT-10D	1,470	104	60	1.5	1	11,76	17,64
GGT-20D	2,770	204	60	1.5	1	22,16	33,24
GGT-30D	5,650	304	60	2	1	45,20	67,80
GGT-40D	8,650	404	60	2	1,5	69,20	103,80
GGT-50D	11,900	504	60	2	1,5	95,20	142,80
GGT-60D	15,850	604	60	2	1,5	126,80	190,20
GGT-A10D	1,650	104	70	1.5	1	13,20	19,80
GGT-A20D	3,000	204	70	1.5	1	24,00	36,00
GGT-A30D	5,900	304	70	2	1	47,20	70,80
GGT-A40D	9,000	404	70	2	1,5	72,00	108,00
GGT-A50D	12,300	504	70	2	1,5	98,40	147,60
GGT-A60D	16,200	604	70	2	1,5	129,60	194,40

Geçmeli Kapaklı "T" Bağlantı Elemanı Tee "T" With Clamping

T-образный Элемент с Выдвигающийся Крышкой

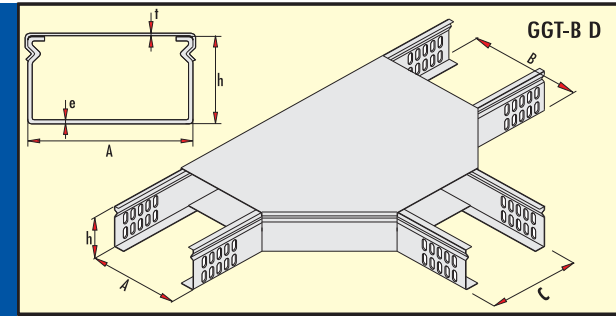

Sipariş kodu Order code Код заявки	Ağırlık (Kg/ad.) Weight (Kg/unit) Вес (кг / шт)	A-B-C mm	h mm	e mm	t mm	Price list прайс-лист шт /у.е.	
						Pre-Galvanized Предв. Цинк-ия	Hot dip Galvanized гор.оцинк. HDZ
GGT-B10D	1,850	104	100	1.5	1	14,80	22,20
GGT-B20D	3,300	204	100	1.5	1	26,40	39,60
GGT-B30D	6,400	304	100	2	1	51,20	76,80
GGT-B40D	9,650	404	100	2	1,5	77,20	115,80
GGT-B50D	12,800	504	100	2	1,5	102,40	153,60
GGT-B60D	16,800	604	100	2	1,5	134,40	201,60

Kaplama : TS 914 EN ISO-1461 (BS-EN-ISO-1461) Sıcak Daldırma Galvaniz.  
Bu Ürünler İsteğe Bağlı Olarak Pregalvaniz ve CORTEN-A Saçdan İmal Edilebilir.

Coating : TS 914 EN ISO-1461 (BS-EN-ISO-1461) Hot Dip Galvanized  
These products can be produced from Pregalvanized or CORTEN-A Steel according to the requirements.

İsteğe bağlı olarak dönüş elemanlarının taban saçları delikli olarak imal edilir.

According to the requirements base plate of the bends, Tees, Cross can be produced as perforated.

Согласно опорной плите требований изгибов, Тиса, Крест может быть произведен как перфорировано.

Talep üzerine tüm ürünler RODINO 50® malzemesi ile kaplanarak (max) 400°C ısıya, asit, tuz ve kum etkilerine karşı mukavemet sağlar.

In case of required all type of materials can be coated with RODINO 50® which will give on extra resistant at effect of 400°C heat, acid, salt and sand for the material.



## GEÇMELİ KAPAKLI KABLO KANALI DÖNÜŞ ELEMANI Bend Elements For Cable Trays With Clamping Lid

Угловые Элементы Кабельных Лотков с Выдвигающийся Крышкой

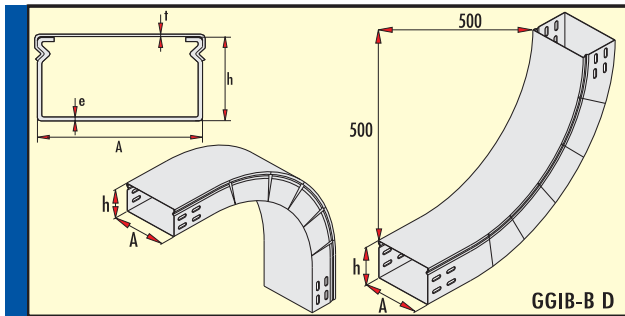
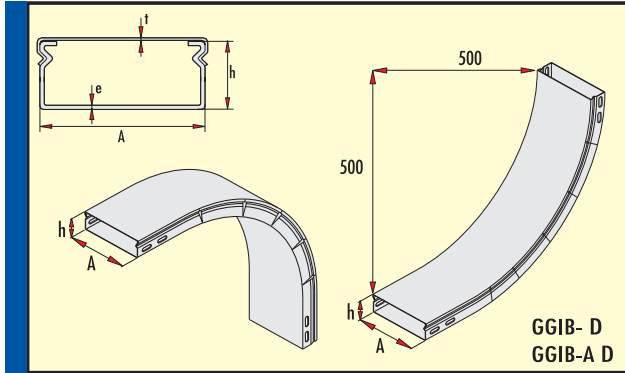
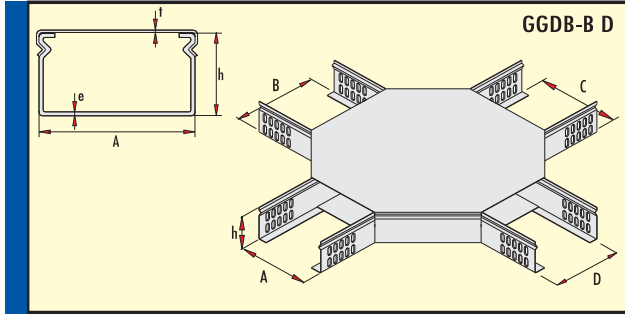
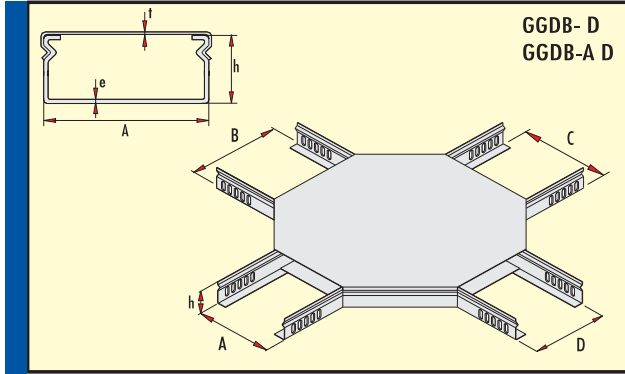

Geçmeli Kapaklı Dörtlü Bağlantı Elemanı							Crossings With Clamping Lid	
Крестообразный Элемент с Выдвигающийся Крышкой								
Sipariş kodu Order code Код заявки	Ağırlık (Kg/ad.) Weight (Kg/unit) Вес (кг/шт)	A-B-C-D mm	h mm	e mm	t mm	Price list прайс-лист шт./у.е.		
						Pre-Galvanized Предв. Цинк-ия	Hot dip Galvanized гор.оцинк. HDZ	
GGDB-10 D	1,880	104	60	1.5	1	15,04	22,56	
GGDB-20 D	3,250	204	60	1.5	1	26,00	39,00	
GGDB-30 D	6,350	304	60	2	1	50,80	76,20	
GGDB-40 D	9,650	404	60	2	1.5	77,20	115,80	
GGDB-50 D	12,330	504	60	2	1.5	98,64	147,96	
GGDB-60 D	16,450	604	60	2	1.5	131,60	197,40	
GGDB-A10 D	2,000	104	70	1.5	1	16,00	24,00	
GGDB-A20 D	3,500	204	70	1.5	1	28,00	42,00	
GGDB-A30 D	6,600	304	70	2	1	52,80	79,20	
GGDB-A40 D	10,100	404	70	2	1.5	80,80	121,20	
GGDB-A50 D	12,650	504	70	2	1.5	101,20	151,80	
GGDB-A60 D	16,700	604	70	2	1.5	133,60	200,40	

Geçmeli Kapaklı Dörtlü Bağlantı Elemanı							Crossings With Clamping Lid	
Крестообразный Элемент с Выдвигающийся Крышкой								
Sipariş kodu Order code Код заявки	Ağırlık (Kg/ad.) Weight (Kg/unit) Вес (кг/шт)	A-B-C-D mm	h mm	e mm	t mm	Price list прайс-лист шт./у.е.		
						Pre-Galvanized Предв. Цинк-ия	Hot dip Galvanized гор.оцинк. HDZ	
GGDB-B10 D	2,500	104	100	1.5	1	20,00	30,00	
GGDB-B20 D	3,800	204	100	1.5	1	30,40	45,60	
GGDB-B30 D	7,400	304	100	2	1	59,20	88,80	
GGDB-B40 D	10,500	404	100	2	1.5	84,00	126,00	
GGDB-B50 D	13,600	504	100	2	1.5	108,80	163,20	
GGDB-B60 D	17,500	604	100	2	1.5	140,00	210,00	

Geçmeli Kapaklı İç-Dış Büküye Bağlantılar							Inside and Outside Vertical With Clamping Lid	
Наружный-Внутренний Угловой Элемент с Выдв. Крышкой								
Sipariş kodu Order code Код заявки	Ağırlık (Kg/ad.) Weight (Kg/unit) Вес (кг/шт)	A mm	h mm	e mm	t mm	Price list прайс-лист шт./у.е.		
						Pre-Galvanized Предв. Цинк-ия	Hot dip Galvanized гор.оцинк. HDZ	
GGIB-10 D	2,600	104	60	1.5	1	20,80	31,20	
GGIB-20 D	5,000	204	60	1.5	1	40,00	60,00	
GGIB-30 D	7,550	304	60	2	1	60,40	90,60	
GGIB-40 D	11,450	404	60	2	1.5	91,60	137,40	
GGIB-50 D	13,450	504	60	2	1.5	107,60	161,40	
GGIB-60 D	15,700	604	60	2	1.5	125,60	188,40	
GGIB-A10 D	2,800	104	70	1.5	1	22,40	33,60	
GGIB-A20 D	5,150	204	70	1.5	1	41,20	61,80	
GGIB-A30 D	8,100	304	70	2	1	64,80	97,20	
GGIB-A40 D	11,900	404	70	2	1.5	95,20	142,80	
GGIB-A50 D	13,900	504	70	2	1.5	111,20	166,80	
GGIB-A60 D	15,900	604	70	2	1.5	127,20	190,80	

Geçmeli Kapaklı İç-Dış Büküye Bağlantılar							Inside and Outside Vertical With Clamping Lid	
Внутри и снаружи Вертикальных Изгибов С Зажимом Крышки								
Sipariş kodu Order code Код заявки	Ağırlık (Kg/ad.) Weight (Kg/unit) Вес (кг/шт)	A mm	h mm	e mm	t mm	Price list прайс-лист шт./у.е.		
						Pre-Galvanized Предв. Цинк-ия	Hot dip Galvanized гор.оцинк. HDZ	
GGIB-B10 D	4,100	104	100	1.5	1	32,80	49,20	
GGIB-B20 D	5,650	204	100	1.5	1	45,20	67,80	
GGIB-B30 D	8,300	304	100	2	1	66,40	99,60	
GGIB-B40 D	12,700	404	100	2	1.5	101,60	152,40	
GGIB-B50 D	14,700	504	100	2	1.5	117,60	176,40	
GGIB-B60 D	17,000	604	100	2	1.5	136,00	204,00	

Kaplama : TS 914 EN ISO-1461 (BS-EN-ISO-1461) Sıcak Daldırma Galvaniz.  
Bu Ürünler İsteğe Bağlı Olarak Pregalvaniz ve CORTEN-A Saçdan İmal Edilebilir.

Coating : TS 914 EN ISO-1461 (BS-EN-ISO-1461) Hot Dip Galvanized  
These products can be produced from Pregalvanized or CORTEN-A Steel according to the requirements.

İsteğe bağlı olarak dönüş elemanlarının taban saçları delikli olarak imal edilir.

According to the requirements base plate of the bends, Tees, Cross can be produced as perforated.

Согласно опорной плите требований изгибов, Тиса, Крест может быть произведен как перфорировано.

Talep üzerine tüm ürünler RODINO 50® malzemesi ile kaplanarak (max) 400°C ısıya, asit, tuz ve kum etkilerine karşı mukavemet sağlar.

In case of required all type of materials can be coated with RODINO 50® which will give on extra resistant at effect of 400°C heat, acid, salt and sand for the material.

**PREGALVANİZ TRUNKING SİSTEMİ** Quick Fix Pregalvanized Cable Trunking Предгальванизированный Кабельный Ствол

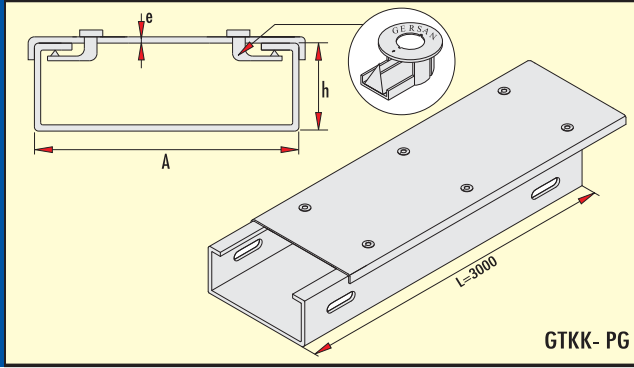

**Pregalvaniz Trunking System (h=50)**  
Quick Fix Pregalvanized Cable Trunking (h=50)

Кабельный Ствол (Магистраль)

Sipariş kodu Order code Код заявки	Ağırlık (Kg/mt.) Weight (Kg/mt) Вес (кг/м)	A mm	h mm	e mm	Price list прайс-лист М/у.е.	
					Pre-Galvanized Предв. Цинк-ия	Hot dip Galvanized гор.оцинк. HDZ
GTKK-5 PG	2,100	50	50	1	10,50	19,00
GTKK-7,5 PG	2,500	75	50	1	12,50	22,50
GTKK-10 PG	2,900	100	50	1	14,50	26,00
GTKK-15 PG	3,700	150	50	1	18,50	33,00
GTKK-20 PG	4,500	200	50	1	22,50	41,00

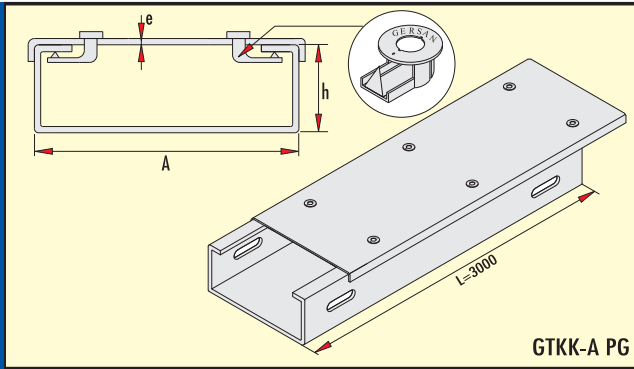

**Pregalvaniz Trunking System (h=75)**  
Quick Fix Pregalvanized Cable Trunking (h=75)

Кабельный Ствол (Магистраль)

Sipariş kodu Order code Код заявки	Ağırlık (Kg/mt.) Weight (Kg/mt) Вес (кг/м)	A mm	h mm	e mm	Price list прайс-лист М/у.е.	
					Pre-Galvanized Предв. Цинк-ия	Hot dip Galvanized гор.оцинк. HDZ
GTKK-A7,5 PG	2,900	75	75	1	14,50	26,00
GTKK-A10 PG	3,400	100	75	1	17,00	31,00
GTKK-A15 PG	4,300	150	75	1	21,50	39,00
GTKK-A20 PG	5,200	200	75	1	26,00	47,00

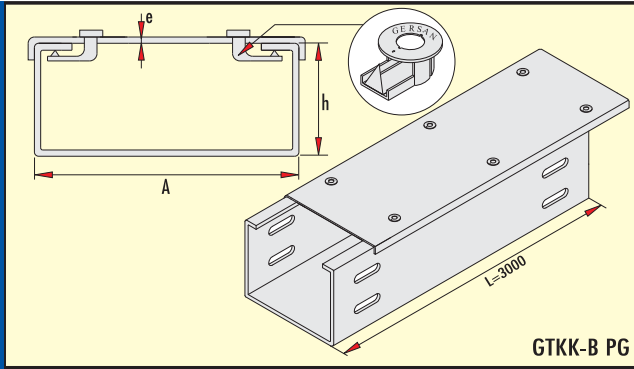

**Pregalvaniz Trunking System (h=100 mm)**  
Quick Fix Pregalvanized Cable Trunking (h=100 mm)

Кабельный Ствол (Магистраль)

Sipariş kodu Order code Код заявки	Ağırlık (Kg/mt.) Weight (Kg/mt) Вес (кг/м)	A mm	h mm	e mm	Price list прайс-лист М/у.е.	
					Pre-Galvanized Предв. Цинк-ия	Hot dip Galvanized гор.оцинк. HDZ
GTKK - B 10 PG	3,900	100	100	1	19,50	35,00
GTKK - B 15 PG	5,000	150	100	1	25,00	45,00
GTKK - B 20 PG	6,000	200	100	1	30,00	54,00

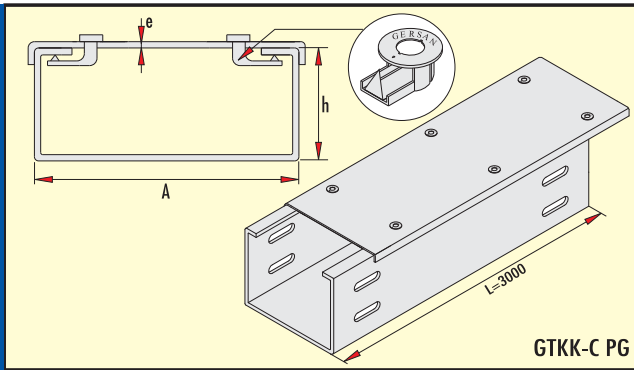

**Pregalvaniz Trunking System (h=150)**  
Quick Fix Pregalvanized Cable Trunking (h=150)

Кабельный Ствол (Магистраль)

Sipariş kodu Order code Код заявки	Ağırlık (Kg/mt.) Weight (Kg/mt) Вес (кг/м)	A mm	h mm	e mm	Price list прайс-лист М/у.е.	
					Pre-Galvanized Предв. Цинк-ия	Hot dip Galvanized гор.оцинк. HDZ
GTKK-C15 PG	5,300	150	150	1	27,00	48,00
GTKK-C20 PG	6,300	200	150	1	32,00	57,00

İsteğe Bağlı Olarak Separatörlü İmal Edilebilir.

If Required Cable Trunkings Can Be Supplied With Compartments.

Если Необходимый Кабельный Ствол Может Быть Снабжен Купе.

Bu Ürünler İsteğe Bağlı Olarak TSE 914 EN ISO 1461(BS-EN-ISO 1461) Sıcak Daldırma Galvaniz İmal Edilebilir.

These products can be produced from TSE 914 EN ISO 1461 (BS-EN-ISO 1461) Hot Dip Galvanized according to the requirements.

Talep üzerine tüm ürünler RODINO 50® malzemesi ile kaplanarak (max) 400°C ısıya, asit, tuz ve kum etkilerine karşı mukavemet sağlar.

In case of required all type of materials can be coated with RODINO 50® which will give on extra resistant at effect of 400°C heat, acid, salt and sand for the material.

**PREGALVANİZ TRUNKING SİSTEMİ 90° DÖNÜŞ ELEMANLARI** 90° Bend Elements Quick Fix Pregalvanized Cable Trunking  
Предгальванизированный Кабельный Ствол 90° Элементов Изгиба

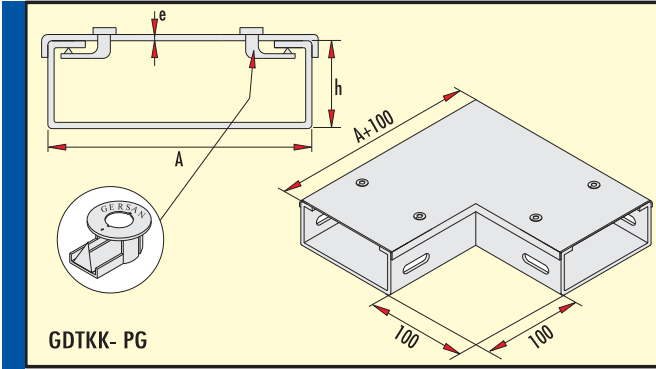

**Pregalvaniz Trunking Sistem 90° Dönüş Elemanı (h=50 mm)**  
90° Bend Elements Quick Fix Pregalvanized Cable Trunking (h=50 mm)

Предгальванизированный Кабельный Ствол 90° Элементов Изгиба

Sipariş kodu Order code Код заявки	Ağırlık (Kg/ad.) Weight (Kg/unit) Вес (кг/шт)	A mm	h mm	e mm	Price list прайс-лист шт./y.e.	
					Pre-Galvanized Предв. Цинк-ия	Hot dip Galvanized гор.оцинк. HDZ
GDTKK-5 PG	0,470	50	50	1	4,70	6,58
GDTKK-7.5 PG	0,700	75	50	1	7,00	9,80
GDTKK-10 PG	0,860	100	50	1	8,60	12,04
GDTKK-15 PG	1,260	150	50	1	12,60	17,64
GDTKK-20 PG	1,770	200	50	1	17,70	24,78

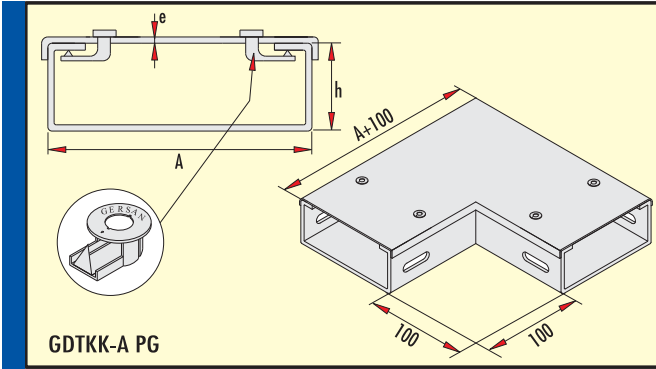

**Pregalvaniz Trunking Sistem 90° Dönüş Elemanı (h=75 mm)**  
90° Bend Elements Quick Fix Pregalvanized Cable Trunking (h=75 mm)

Предгальванизированный Кабельный Ствол 90° Элементов Изгиба

Sipariş kodu Order code Код заявки	Ağırlık (Kg/ad.) Weight (Kg/unit) Вес (кг/шт)	A mm	h mm	e mm	Price list прайс-лист шт./y.e.	
					Pre-Galvanized Предв. Цинк-ия	Hot dip Galvanized гор.оцинк. HDZ
GDTKK-A7.5 PG	0,760	75	75	1	7,60	10,64
GDTKK-A10 PG	0,960	100	75	1	9,60	13,44
GDTKK-A15 PG	1,320	150	75	1	13,20	18,48
GDTKK-A20 PG	1,780	200	75	1	17,80	24,92

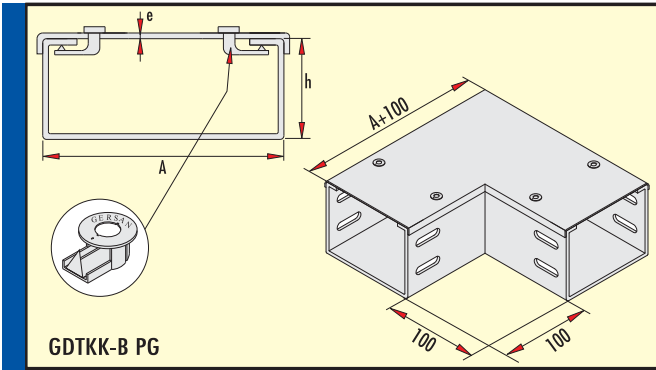

**Pregalvaniz Trunking Sistem 90° Dönüş Elemanı (h=100 mm)**  
90° Bend Elements Quick Fix Pregalvanized Cable Trunking (h=100 mm)

Предгальванизированный Кабельный Ствол 90° Элементов Изгиба

Sipariş kodu Order code Код заявки	Ağırlık (Kg/ad.) Weight (Kg/unit) Вес (кг/шт)	A mm	h mm	e mm	Price list прайс-лист шт./y.e.	
					Pre-Galvanized Предв. Цинк-ия	Hot dip Galvanized гор.оцинк. HDZ
GDTKK-B10 PG	0,840	100	100	1	8,40	11,76
GDTKK-B15 PG	1,450	150	100	1	14,50	20,30
GDTKK-B20 PG	1,960	200	100	1	19,60	27,44

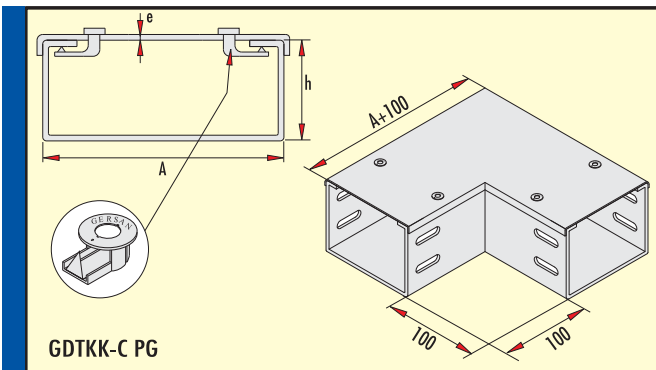

**Pregalvaniz Trunking Sistem 90° Dönüş Elemanı (h=150 mm)**  
90° Bend Elements Quick Fix Pregalvanized Cable Trunking (h=150 mm)

Предгальванизированный Кабельный Ствол 90° Элементов Изгиба

Sipariş kodu Order code Код заявки	Ağırlık (Kg/ad.) Weight (Kg/unit) Вес (кг/шт)	A mm	h mm	e mm	Price list прайс-лист шт./y.e.	
					Pre-Galvanized Предв. Цинк-ия	Hot dip Galvanized гор.оцинк. HDZ
GDTKK-C15 PG	1,660	150	150	1	16,60	23,24
GDTKK-C20 PG	2,250	200	150	1	22,50	31,50

Bu Ürünler İsteğe Bağlı Olarak TSE 914 EN ISO 1461 (BS-EN-ISO 1461) Sıcak Daldırma Olarak İmal Edilebilir. These products can be produced from TSE 914 EN ISO 1461 (BS-EN-ISO 1461) according to the requirements.

Talep üzerine tüm ürünler RODINA 50® malzemesi ile kaplanarak (max) 400°C ısıya, asit, tuz ve kum etkilerine karşı mukavemet sağlar.  
In case of required all type of materials can be coated with RODINA 50® which will give on extra resistant at effect of 400°C heat, acid, salt and sand for the material.

**PREGALVANİZ TRUNKING SİSTEMİ 45° DÖNÜŞ ELEMANLARI** 45° Bend Elements Quick Fix Pregalvanized Cable Trunking  
Предгальванизированный Кабельный Ствол 45° Элементов Изгиба

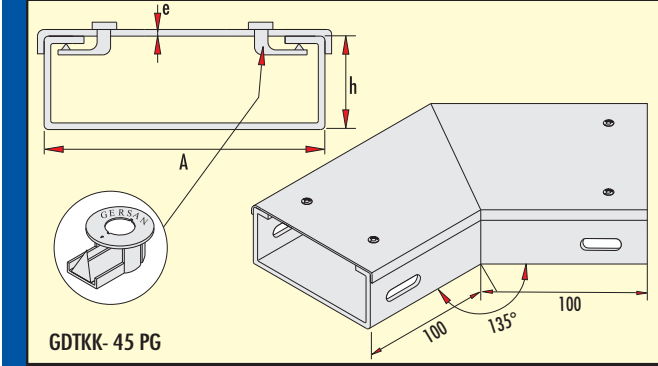

**Pregalvaniz Trunking Sistem 45° Dönüş Elemanı (h=50 mm)**  
45° Bend Elements Quick Fix Pregalvanized Cable Trunking (h=50 mm)  
Предгальванизированный Кабельный Ствол 45° Элементов Изгиба

Sipariş kodu Order code Код заявки	Ağırlık (Kg/ad.) Weight (Kg/unit) Вес (кг /шт)	A mm	h mm	e mm	Price list прайс-лист шт /у.е.	
					Pre-Galvanized Предв. Цинк-ия	Hot dip Galvanized гор.оцинк. HDZ
GDTKK-5-45 PG	0,490	50	50	1	4,90	6,86
GDTKK-7.5-45 PG	0,720	75	50	1	7,20	10,08
GDTKK-10-45 PG	0,880	100	50	1	8,80	12,32
GDTKK-15-45 PG	1,480	150	50	1	14,80	20,72
GDTKK-20-45 PG	1,970	200	50	1	19,70	27,58

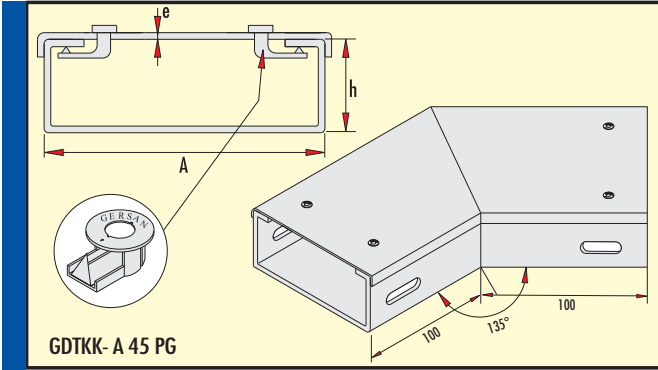

**Pregalvaniz Trunking Sistem 45° Dönüş Elemanı (h=75 mm)**  
45° Bend Elements Quick Fix Pregalvanized Cable Trunking (h=75 mm)  
Предгальванизированный Кабельный Ствол 45° Элементов Изгиба

Sipariş kodu Order code Код заявки	Ağırlık (Kg/ad.) Weight (Kg/unit) Вес (кг /шт)	A mm	h mm	e mm	Price list прайс-лист шт /у.е.	
					Pre-Galvanized Предв. Цинк-ия	Hot dip Galvanized гор.оцинк. HDZ
GDTKK-A7.5-45 PG	0,790	75	75	1	7,90	11,06
GDTKK-A10-45 PG	0,980	100	75	1	9,80	13,72
GDTKK-A15-45 PG	1,340	150	75	1	13,40	18,76
GDTKK-A20-45 PG	1,800	200	75	1	18,00	25,20

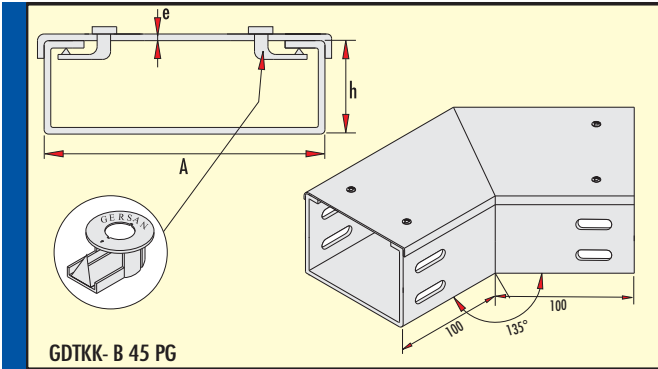

**Pregalvaniz Trunking Sistem 45° Dönüş Elemanı (h=100 mm)**  
45° Bend Elements Quick Fix Pregalvanized Cable Trunking (h=100 mm)  
Предгальванизированный Кабельный Ствол 45° Элементов Изгиба

Sipariş kodu Order code Код заявки	Ağırlık (Kg/ad.) Weight (Kg/unit) Вес (кг /шт)	A mm	h mm	e mm	Price list прайс-лист шт /у.е.	
					Pre-Galvanized Предв. Цинк-ия	Hot dip Galvanized гор.оцинк. HDZ
GDTKK-B10-45 PG	0,860	100	100	1	8,60	12,04
GDTKK-B15-45 PG	1,470	150	100	1	14,70	20,58
GDTKK-B20-45 PG	1,980	200	100	1	19,80	27,72

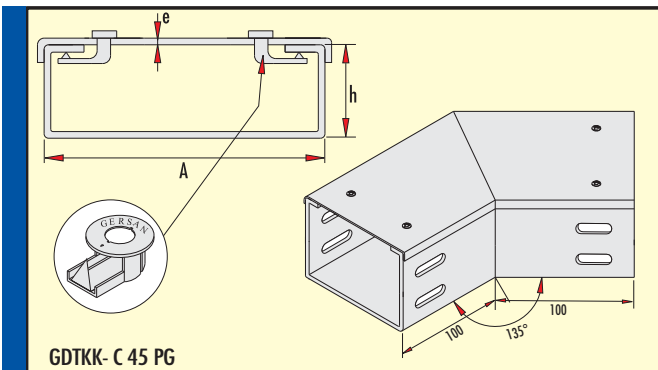

**Pregalvaniz Trunking Sistem 45° Dönüş Elemanı (h=150 mm)**  
45° Bend Elements Quick Fix Pregalvanized Cable Trunking (h=150 mm)  
Предгальванизированный Кабельный Ствол 45° Элементов Изгиба

Sipariş kodu Order code Код заявки	Ağırlık (Kg/ad.) Weight (Kg/unit) Вес (кг /шт)	A mm	h mm	e mm	Price list прайс-лист шт /у.е.	
					Pre-Galvanized Предв. Цинк-ия	Hot dip Galvanized гор.оцинк. HDZ
GDTKK-C15-45 PG	1,680	150	150	1	16,80	23,52
GDTKK-C20-45 PG	2,270	200	150	1	22,70	31,78

Bu Ürünler İsteğe Bağlı Olarak TSE 914 EN ISO 1461(BS-EN-ISO 1461) Sıcak Daldırma Olarak İmal Edilebilir. These products can be produced from TSE 914 EN ISO 1461 (BS-EN-ISO 1461) according to the requirements.

Talep üzerine tüm ürünler RODINA 50® malzemesi ile kaplanarak (max) 400°C ısıya, asit, tuz ve kum etkilerine karşı mukavemet sağlar.  
In case of required all type of materials can be coated with RODINA 50® which will give on extra resistant at effect of 400°C heat, acid, salt and sand for the material.



**PREGALVANİZ TRUNKING SİSTEMİ "T" BAĞLANTI ELEMANLARI Tee "T" Elements Quick Fix Pregalvanized Cable Trunking**  
Мишень "Т" Элемент Для Предгальванизированного Кабельного Ствола

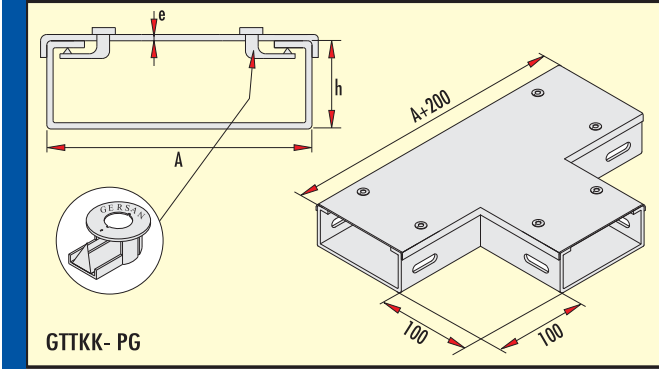

**Pregalvaniz Trunking Sistem "T" Bağlantı Elemanı (h=50 mm)**

**Tee "T" Elements Quick Fix Pregalvanized Cable Trunking (h=50 mm)**

Мишень "Т" Элемент Для Предгальванизированного Кабельного Ствола

Sipariş kodu Order code Код заявки	Ağırlık (Kg/ad.) Weight (Kg/unit) Вес (кг/шт)	A mm	h mm	e mm	Price list прайс-лист шт/у.е.	
					Pre-Galvanized Предв. Цинк-ия	Hot dip Galvanized гор.оцинк. HDZ
GTTKK- 5 PG	0,750	50	50	1	7,50	10,50
GTTKK- 7,5 PG	0,950	75	50	1	9,50	13,30
GTTKK- 10 PG	1,170	100	50	1	11,70	16,38
GTTKK- 15 PG	1,670	150	50	1	16,70	23,38
GTTKK- 20 PG	2,240	200	50	1	22,40	31,36

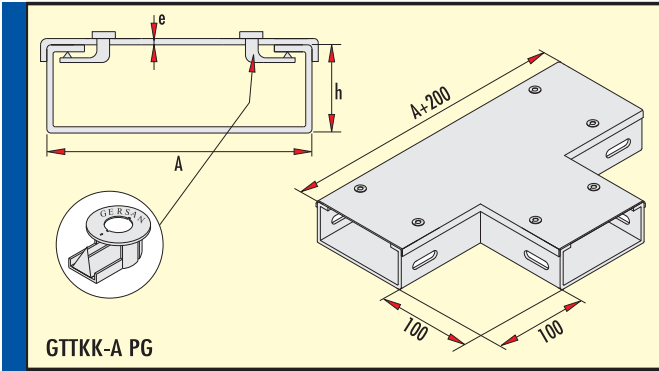

**Pregalvaniz Trunking Sistem "T" Bağlantı Elemanı (h=75 mm)**

**Tee "T" Elements Quick Fix Pregalvanized Cable Trunking (h=75 mm)**

Мишень "Т" Элемент Для Предгальванизированного Кабельного Ствола

Sipariş kodu Order code Код заявки	Ağırlık (Kg/ad.) Weight (Kg/unit) Вес (кг/шт)	A mm	h mm	e mm	Price list прайс-лист шт/у.е.	
					Pre-Galvanized Предв. Цинк-ия	Hot dip Galvanized гор.оцинк. HDZ
GTTKK-A7.5 PG	1,100	75	75	1	11,00	15,40
GTTKK- A10 PG	1,330	100	75	1	13,30	18,62
GTTKK- A15 PG	1,850	150	75	1	18,50	25,90
GTTKK- A20 PG	2,450	200	75	1	24,50	34,30

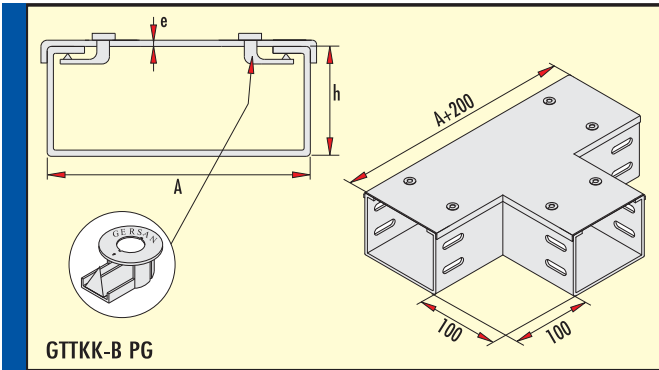

**Pregalvaniz Trunking Sistem "T" Bağlantı Elemanı (h=100 mm)**

**Tee "T" Elements Quick Fix Pregalvanized Cable Trunking (h=100 mm)**

Мишень "Т" Элемент Для Предгальванизированного Кабельного Ствола

Sipariş kodu Order code Код заявки	Ağırlık (Kg/ad.) Weight (Kg/unit) Вес (кг/шт)	A mm	h mm	e mm	Price list прайс-лист шт/у.е.	
					Pre-Galvanized Предв. Цинк-ия	Hot dip Galvanized гор.оцинк. HDZ
GTTKK- B10 PG	1,490	100	100	1	14,90	20,86
GTTKK- B15 PG	2,030	150	100	1	20,30	28,42
GTTKK- B20 PG	2,610	200	100	1	26,10	36,54

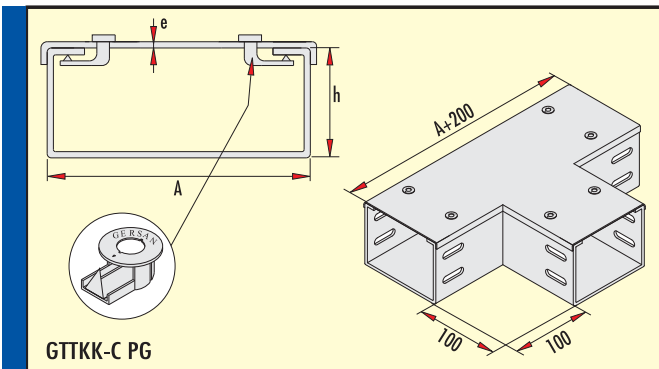

**Pregalvaniz Trunking Sistem "T" Bağlantı Elemanı (h=150 mm)**

**Tee "T" Elements Quick Fix Pregalvanized Cable Trunking (h=150 mm)**

Мишень "Т" Элемент Для Предгальванизированного Кабельного Ствола

Sipariş kodu Order code Код заявки	Ağırlık (Kg/ad.) Weight (Kg/unit) Вес (кг/шт)	A mm	h mm	e mm	Price list прайс-лист шт/у.е.	
					Pre-Galvanized Предв. Цинк-ия	Hot dip Galvanized гор.оцинк. HDZ
GTTKK- C15 PG	2,390	150	150	1	23,90	33,46
GTTKK- C20 PG	3,040	200	150	1	30,40	42,56

Bu Ürünler İsteğe Bağlı Olarak TSE 914 EN ISO 1461 (BS-EN-ISO 1461) Sıcak Daldırma Olarak İmal Edilebilir. These products can be produced from TSE 914 EN ISO 1461 (BS-EN-ISO 1461) according to the requirements.

Talep üzerine tüm ürünler RODINO 50® malzemesi ile kaplanarak (max) 400°C ısıya, asit, tuz ve kum etkilerine karşı mukavemet sağlar.

In case of required all type of materials can be coated with RODINO 50® which will give on extra resistant at effect of 400°C heat, acid, salt and sand for the material.

**PREGALVANİZ TRUNKING SİSTEMİ DÖRTLÜ BAĞLANTI ELEMANLARI** *Crossing Elements Quick Fix Pregalvanized Cable Trunking*  
Пересечение Элемента Для Предгальванизированного Кабельного Ствола

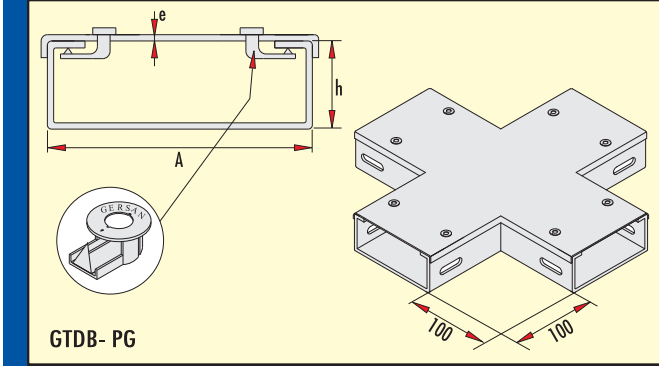

Pregalvaniz Trunking Sistem Dörtlü Bağlantı Elemanı (h=50 mm) <i>Crossing Elements Quick Fix Pregalvanized Cable Trunking (h=50 mm)</i> Пересечение Элемента Для Предгальванизированного Кабельного Ствола						
Sipariş kodu Order code Код заявки	Ağırlık (Kg/ad.) Weight (Kg/unit) Вес (кг /шт)	A mm	h mm	e mm	Price list прайс-лист шт./у.е.	
					Pre-Galvanized Предв. Цинк-ия	Hot dip Galvanized гор.оцинк. HDZ
GTDB-5 PG	0,915	50	50	1	9,10	12,74
GTDB-7.5 PG	1,060	75	50	1	10,60	14,84
GTDB-10 PG	1,330	100	50	1	13,30	18,62
GTDB-15 PG	1,850	150	50	1	18,50	25,90
GTDB-20 PG	2,450	200	50	1	24,50	34,30

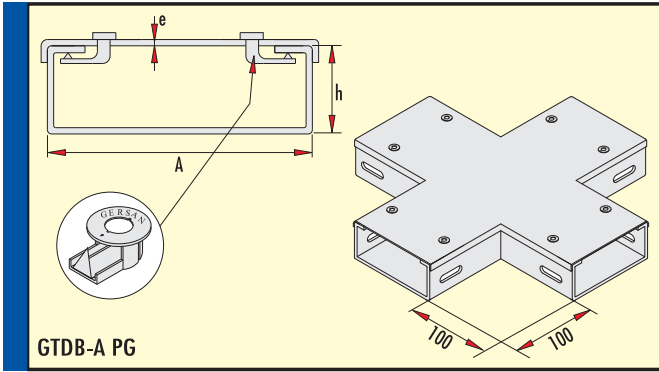

Pregalvaniz Trunking Sistem Dörtlü Bağlantı Elemanı (h=75 mm) <i>Crossing Elements Quick Fix Pregalvanized Cable Trunking (h=75 mm)</i> Пересечение Элемента Для Предгальванизированного Кабельного Ствола						
Sipariş kodu Order code Код заявки	Ağırlık (Kg/ad.) Weight (Kg/unit) Вес (кг /шт)	A mm	h mm	e mm	Price list прайс-лист шт./у.е.	
					Pre-Galvanized Предв. Цинк-ия	Hot dip Galvanized гор.оцинк. HDZ
GTDB-A7.5 PG	1,260	75	75	1	12,60	17,64
GTDB-A10 PG	1,490	100	75	1	14,90	20,86
GTDB-A15 PG	2,010	150	75	1	20,10	28,14
GTDB-A20 PG	2,610	200	75	1	26,10	36,54

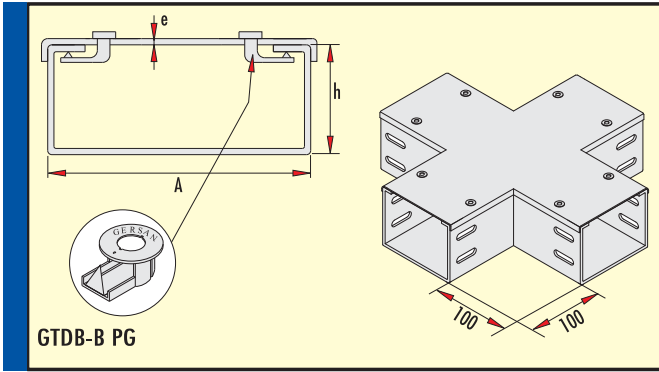

Pregalvaniz Trunking Sistem Dörtlü Bağlantı Elemanı (h=100 mm) <i>Crossing Elements Quick Fix Pregalvanized Cable Trunking (h=100 mm)</i> Пересечение Элемента Для Предгальванизированного Кабельного Ствола						
Sipariş kodu Order code Код заявки	Ağırlık (Kg/ad.) Weight (Kg/unit) Вес (кг /шт)	A mm	h mm	e mm	Price list прайс-лист шт./у.е.	
					Pre-Galvanized Предв. Цинк-ия	Hot dip Galvanized гор.оцинк. HDZ
GTDB-B10 PG	1,650	100	100	1	16,50	23,10
GTDB-B15 PG	2,170	150	100	1	21,70	30,38
GTDB-B20 PG	2,770	200	100	1	27,70	38,78

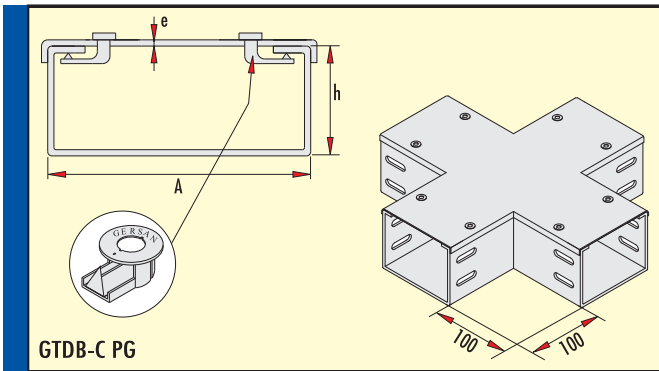

Pregalvaniz Trunking Sistemi Dörtlü Bağlantı Elemanı (h=150 mm) <i>Crossing Element For Pregalvanized Cable Trunking (h=150 mm)</i> Пересечение Элемента Для Предгальванизированного Кабельного Ствола						
Sipariş kodu Order code Код заявки	Ağırlık (Kg/ad.) Weight (Kg/unit) Вес (кг /шт)	A mm	h mm	e mm	Price list прайс-лист шт./у.е.	
					Pre-Galvanized Предв. Цинк-ия	Hot dip Galvanized гор.оцинк. HDZ
GTDB-C15 PG	2,490	150	150	1	24,90	34,86
GTDB-C20 PG	3,040	200	150	1	30,40	42,56

Bu Ürünler İsteğe Bağlı Olarak TSE 914 EN ISO 1461 (BS-EN-ISO 1461) Sıcak Daldırma Olarak İmal Edilebilir. *These products can be produced from TSE 914 EN ISO 1461 (BS-EN-ISO 1461) according to the requirements.*

Talep üzerine tüm ürünler RODINO 50® malzemesi ile kaplanarak (max) 400°C ısıya, asit, tuz ve kum etkilerine karşı mukavemet sağlar.  
*In case of required all type of materials can be coated with RODINO 50® which will give on extra resistant at effect of 400°C heat, acid, salt and sand for the material.*

## PREGALVANİZ TRUNKING SİSTEMİ İÇ BÜKEY DÖNÜŞ ELEMANLARI

### Internal Bend Elements Quick Fix Pregalvanized Cable Trunking

Внутренние Элементы Изгиба Для Предгальванизированного Кабельного Ствола

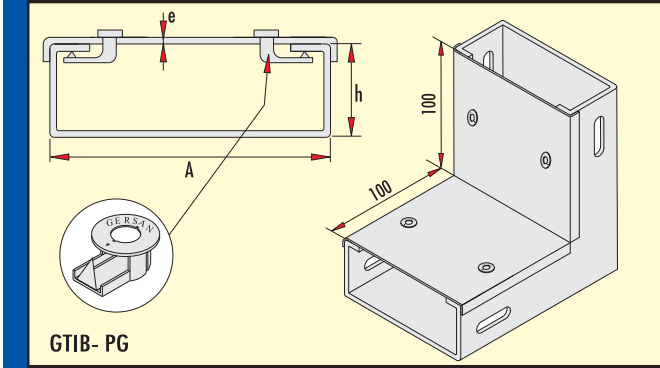

### Pregalvaniz Trunking Sistemi İç Bükey Dönüş Elemanları (h=50 mm)

Internal Bend Elements Quick Fix Pregalvanized Cable Trunking (h=50 mm)

Мишень "Т" Элемент Для Предгальванизированного Кабельного Ствола

Sipariş kodu Order code Код заявки	Ağırlık (Kg/ad.) Weight (Kg/unit) Вес (кг/шт)	A mm	h mm	e mm	Price list прайс-лист шт./у.е.	
					Pre-Galvanized Предв. Цинк-ия	Hot dip Galvanized гор.оцинк. HDZ
GTIB-5 PG	0,500	50	50	1	5,00	7,00
GTIB-7,5 PG	0,630	75	50	1	6,30	8,82
GTIB-10 PG	0,870	100	50	1	8,70	12,18
GTIB-15 PG	1,080	150	50	1	10,80	15,12
GTIB-20 PG	1,450	200	50	1	14,50	20,30

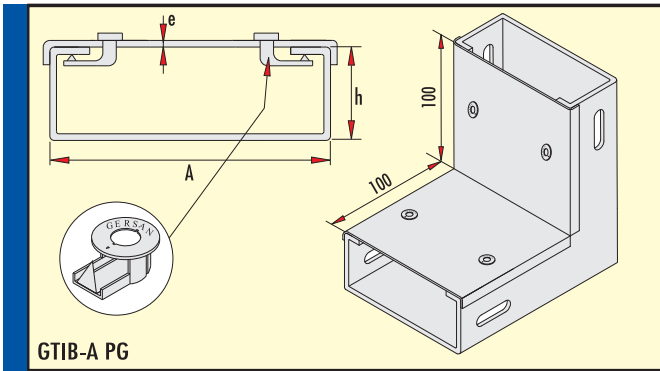

### Pregalvaniz Trunking Sistemi İç Bükey Dönüş Elemanları (h=75 mm)

Internal Bend Elements Quick Fix Pregalvanized Cable Trunking (h=75 mm)

Мишень "Т" Элемент Для Предгальванизированного Кабельного Ствола

Sipariş kodu Order code Код заявки	Ağırlık (Kg/ad.) Weight (Kg/unit) Вес (кг/шт)	A mm	h mm	e mm	Price list прайс-лист шт./у.е.	
					Pre-Galvanized Предв. Цинк-ия	Hot dip Galvanized гор.оцинк. HDZ
GTIB-A7,5 PG	0,740	75	75	1	7,40	10,36
GTIB-A10 PG	0,890	100	75	1	8,90	12,46
GTIB-A15 PG	1,220	150	75	1	12,20	17,08
GTIB-A20 PG	1,590	200	75	1	15,90	22,26

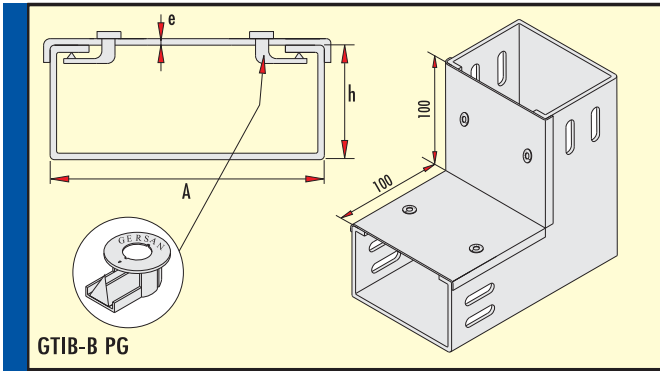

### Pregalvaniz Trunking Sistemi İç Bükey Dönüş Elemanları (h=100 mm)

Internal Bend Elements Quick Fix Pregalvanized Cable Trunking (h=100 mm)

Мишень "Т" Элемент Для Предгальванизированного Кабельного Ствола

Sipariş kodu Order code Код заявки	Ağırlık (Kg/ad.) Weight (Kg/unit) Вес (кг/шт)	A mm	h mm	e mm	Price list прайс-лист шт./у.е.	
					Pre-Galvanized Предв. Цинк-ия	Hot dip Galvanized гор.оцинк. HDZ
GTIB-B10 PG	1,010	100	100	1	10,10	14,14
GTIB-B15 PG	1,360	150	100	1	13,60	19,04
GTIB-B20 PG	1,750	200	100	1	17,50	24,50

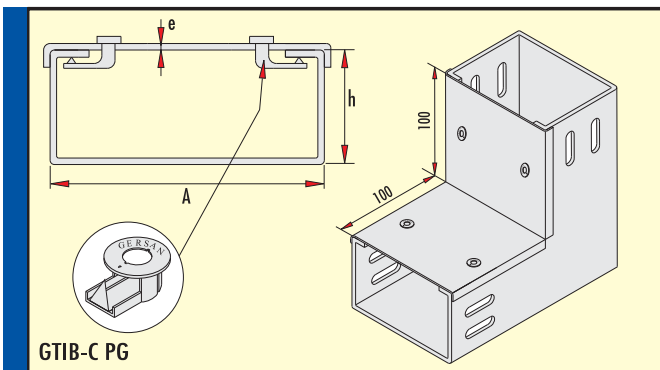

### Pregalvaniz Trunking Sistemi İç Bükey Dönüş Elemanları (h=150 mm)

Internal Bend Elements Quick Fix Pregalvanized Cable Trunking (h=150 mm)

Мишень "Т" Элемент Для Предгальванизированного Кабельного Ствола

Sipariş kodu Order code Код заявки	Ağırlık (Kg/ad.) Weight (Kg/unit) Вес (кг/шт)	A mm	h mm	e mm	Price list прайс-лист шт./у.е.	
					Pre-Galvanized Предв. Цинк-ия	Hot dip Galvanized гор.оцинк. HDZ
GTIB-C15 PG	1,640	150	150	1	16,40	22,96
GTIB-C20 PG	2,070	200	150	1	20,70	28,98

Bu Ürünler İsteğe Bağlı Olarak TSE 914 EN ISO 1461(BS-EN-ISO 1461) Sıcak Daldırma Olarak İmal Edilebilir. These products can be produced from TSE 914 EN ISO 1461 (BS-EN-ISO 1461) according to the requirements.

Talep üzerine tüm ürünler RODINO 50® malzemesi ile kaplanarak (max) 400°C ısıya, asit, tuz ve kum etkilerine karşı mukavemet sağlar.

In case of required all type of materials can be coated with RODINO 50® which will give on extra resistant at effect of 400°C heat, acid, salt and sand for the material.

## PREGALVANİZ TRUNKING SİSTEMİ DIŞ BÜKEY DÖNÜŞ ELEMANLARI

### External Bend Elements Quick Fix Pregalvanized Cable Trunking

Внешние Элементы Изгиба Для Предгальванизированного Кабельного Ствола

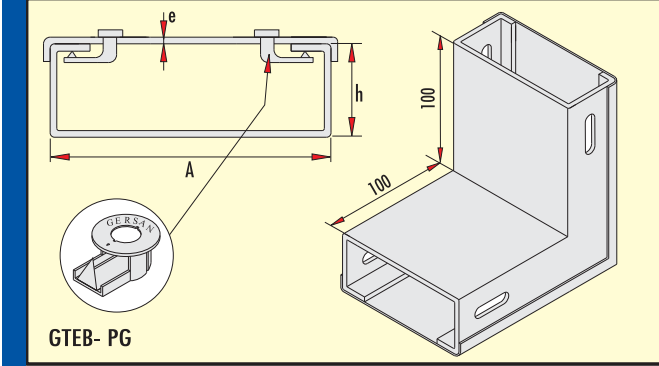

#### Pregalvaniz Trunking Sistemi Dış Bükey Dönüş Elemanları (h=50 mm)

##### External Bend Elements Quick Fix Pregalvanized Cable Trunking (h=50 mm)

Внешние Элементы Изгиба Для Предгальванизированного Кабельного Ствола

Sipariş kodu Order code Код заявки	Ağırlık (Kg/ad.) Weight (Kg/unit) Вес (кг/шт)	A mm	h mm	e mm	Price list прайс-лист шт./y.e.	
					Pre-Galvanized Предв. Цинк-ия	Hot dip Galvanized гор.оцинк. HDZ
GTEB-5 PG	0,560	50	50	1	5,60	7,84
GTEB-7,5 PG	0,750	75	50	1	7,50	10,50
GTEB-10 PG	0,970	100	50	1	9,70	13,58
GTEB-15 PG	1,500	150	50	1	15,00	21,00
GTEB-20 PG	2,150	200	50	1	21,50	30,10

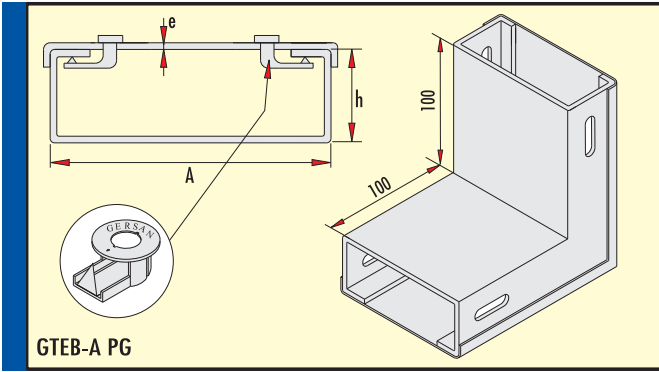

#### Pregalvaniz Trunking Sistemi Dış Bükey Dönüş Elemanları (h=75 mm)

##### External Bend Elements Quick Fix Pregalvanized Cable Trunking (h=75 mm)

Внешние Элементы Изгиба Для Предгальванизированного Кабельного Ствола

Sipariş kodu Order code Код заявки	Ağırlık (Kg/ad.) Weight (Kg/unit) Вес (кг/шт)	A mm	h mm	e mm	Price list прайс-лист шт./y.e.	
					Pre-Galvanized Предв. Цинк-ия	Hot dip Galvanized гор.оцинк. HDZ
GTEB-A7,5 PG	0,860	75	75	1	8,60	12,04
GTEB-A10 PG	1,090	100	75	1	10,90	15,26
GTEB-A15 PG	1,640	150	75	1	16,40	22,96
GTEB-A20 PG	2,300	200	75	1	23,00	32,20

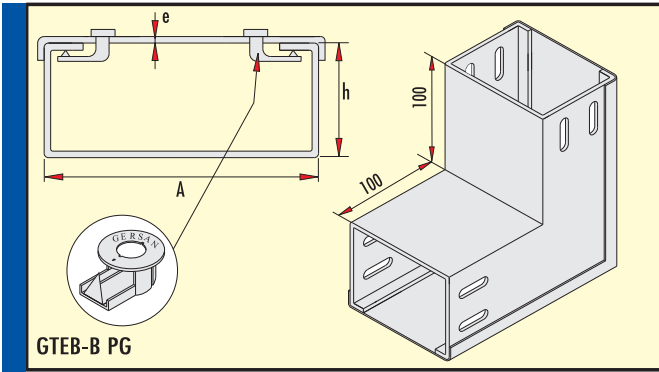

#### Pregalvaniz Trunking Sistemi Dış Bükey Dönüş Elemanları (h=100 mm)

##### External Bend Elements Quick Fix Pregalvanized Cable Trunking (h=100 mm)

Внешние Элементы Изгиба Для Предгальванизированного Кабельного Ствола

Sipariş kodu Order code Код заявки	Ağırlık (Kg/ad.) Weight (Kg/unit) Вес (кг/шт)	A mm	h mm	e mm	Price list прайс-лист шт./y.e.	
					Pre-Galvanized Предв. Цинк-ия	Hot dip Galvanized гор.оцинк. HDZ
GTEB-B10 PG	1,210	100	100	1	12,10	16,94
GTEB-B15 PG	1,780	150	100	1	17,80	24,92
GTEB-B20 PG	2,460	200	100	1	24,60	34,44

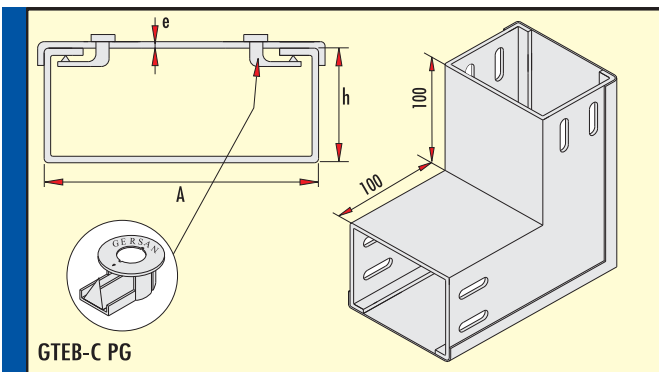

#### Pregalvaniz Trunking Sistemi Dış Bükey Dönüş Elemanları (h=150 mm)

##### External Bend Elements Quick Fix Pregalvanized Cable Trunking (h=150 mm)

Внешние Элементы Изгиба Для Предгальванизированного Кабельного Ствола

Sipariş kodu Order code Код заявки	Ağırlık (Kg/ad.) Weight (Kg/unit) Вес (кг/шт)	A mm	h mm	e mm	Price list прайс-лист шт./y.e.	
					Pre-Galvanized Предв. Цинк-ия	Hot dip Galvanized гор.оцинк. HDZ
GTEB-C15 PG	2,060	150	150	1	20,60	28,84
GTEB-C20 PG	2,780	200	150	1	27,80	38,92

Bu ürünler isteğe bağlı olarak TSE 914 EN ISO 1461 (BS-EN-ISO 1461) Sıcak Daldırma Olarak İmal Edilebilir. These products can be produced from TSE 914 EN ISO 1461 (BS-EN-ISO 1461) according to the requirements.

Talep üzerine tüm ürünler RODINO 50® malzemesi ile kaplanarak (max) 400°C ısıya, asit, tuz ve kum etkilerine karşı mukavemet sağlar.

In case of required all type of materials can be coated with RODINO 50® which will give on extra resistant at effect of 400°C heat, acid, salt and sand for the material.



## PREGALVANİZ TRUNKING SİSTEMİ 45° İÇ BÜKEY DÖNÜŞ ELEMANLARI 45° Internal Bend Elements Quick Fix Pregalvanized Cable Trunking

Внутренние Элементы Изгиба Для Предгальванизированного Кабельного Ствола 45°

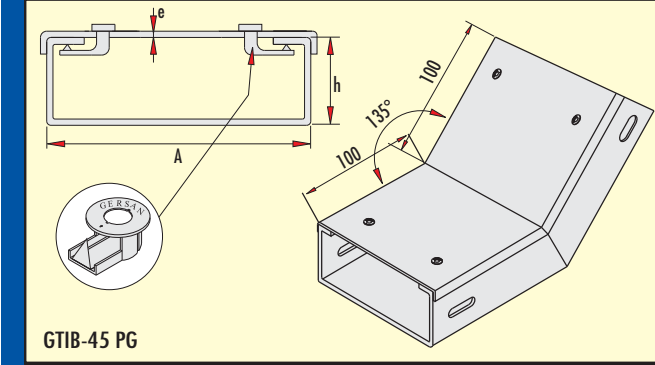

### Pregalvaniz Trunking Sistemi 45° İç Bükey Elemanları (h=50 mm) Internal Bend Elements For Quick Fix Pregalvanized Cable Trunking (h=50 mm)

Внутренние Элементы Изгиба Для Предгальванизированного Кабельного Ствола 45°

Sipariş kodu Order code Код заявки	Ağırlık (Kg/ad.) Weight (Kg/unit) Вес (кг / шт)	A mm	h mm	e mm	Price list прайс-лист шт / у.е.	
					Pre-Galvanized Предв. Цинк-ия	Hot dip Galvanized гор.оцинк. HDZ
GTIB-5-45 PG	0,550	50	50	1	5,50	7,70
GTIB-7.5-45 PG	0,680	75	50	1	6,80	9,52
GTIB-10-45 PG	0,920	100	50	1	9,20	12,88
GTIB-15-45 PG	1,100	150	50	1	11,00	15,40
GTIB-20-45 PG	1,500	200	50	1	15,00	21,00

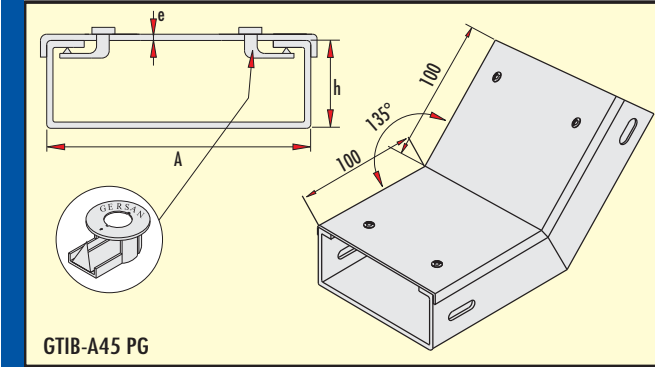

### Pregalvaniz Trunking Sistemi 45° İç Bükey Elemanları (h=75 mm) Internal Bend Elements For Quick Fix Pregalvanized Cable Trunking (h=75 mm)

Внутренние Элементы Изгиба Для Предгальванизированного Кабельного Ствола 45°

Sipariş kodu Order code Код заявки	Ağırlık (Kg/ad.) Weight (Kg/unit) Вес (кг / шт)	A mm	h mm	e mm	Price list прайс-лист шт / у.е.	
					Pre-Galvanized Предв. Цинк-ия	Hot dip Galvanized гор.оцинк. HDZ
GTIB-A7.5-45 PG	0,760	75	75	1	7,60	10,64
GTIB-A10-45 PG	0,910	100	75	1	9,10	12,74
GTIB-A15-45 PG	1,250	150	75	1	12,50	17,50
GTIB-A20-45 PG	1,650	200	75	1	16,50	23,10

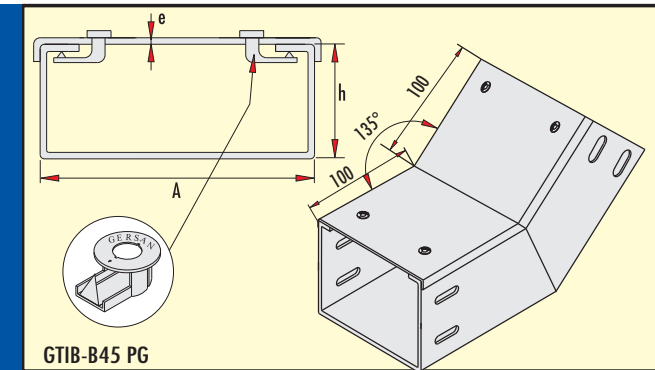

### Pregalvaniz Trunking Sistemi 45° İç Bükey Elemanları (h=100 mm) Internal Bend Elements For Quick Fix Pregalvanized Cable Trunking (h=100 mm)

Внутренние Элементы Изгиба Для Предгальванизированного Кабельного Ствола 45°

Sipariş kodu Order code Код заявки	Ağırlık (Kg/ad.) Weight (Kg/unit) Вес (кг / шт)	A mm	h mm	e mm	Price list прайс-лист шт / у.е.	
					Pre-Galvanized Предв. Цинк-ия	Hot dip Galvanized гор.оцинк. HDZ
GTIB-B10-45 PG	1,050	100	100	1	10,50	14,70
GTIB-B15-45 PG	1,400	150	100	1	14,00	19,60
GTIB-B20-45 PG	1,800	200	100	1	18,00	25,20

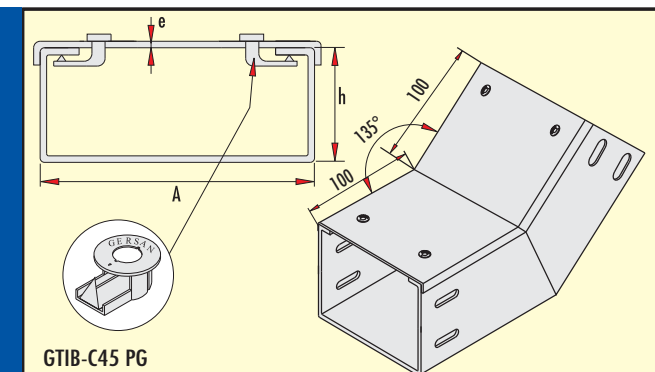

### Pregalvaniz Trunking Sistemi 45° İç Bükey Elemanları (h=100 mm) Internal Bend Elements For Quick Fix Pregalvanized Cable Trunking (h=100 mm)

Внутренние Элементы Изгиба Для Предгальванизированного Кабельного Ствола 45°

Sipariş kodu Order code Код заявки	Ağırlık (Kg/ad.) Weight (Kg/unit) Вес (кг / шт)	A mm	h mm	e mm	Price list прайс-лист шт / у.е.	
					Pre-Galvanized Предв. Цинк-ия	Hot dip Galvanized гор.оцинк. HDZ
GTIB-C15-45 PG	1,700	150	150	1	17,00	23,80
GTIB-C20-45 PG	2,150	200	150	1	21,50	30,10

Bu Ürünler İsteğe Bağlı Olarak TSE 914 EN ISO 1461 (BS-EN-ISO 1461) Sıcak Daldırma Olarak İmal Edilebilir. These products can be produced from TSE 914 EN ISO 1461 (BS-EN-ISO 1461) according to the requirements.

Talep üzerine tüm ürünler RODINO 50® malzemesi ile kaplanarak (max) 400°C ısıya, asit, tuz ve kum etkilerine karşı mukavemet sağlar.  
In case of required all type of materials can be coated with RODINO 50® which will give on extra resistant at effect of 400°C heat, acid, salt and sand for the material.



## PREGALVANİZ TRUNKING SİSTEMİ 45° DİŞ BÜKEY DÖNÜŞ ELEMANLARI 45° External Bend Elements Quick Fix Pregalvanized Cable Trunking

Внутренние Элементы Изгиба Для Предгальванизированного Кабельного Ствола 45°

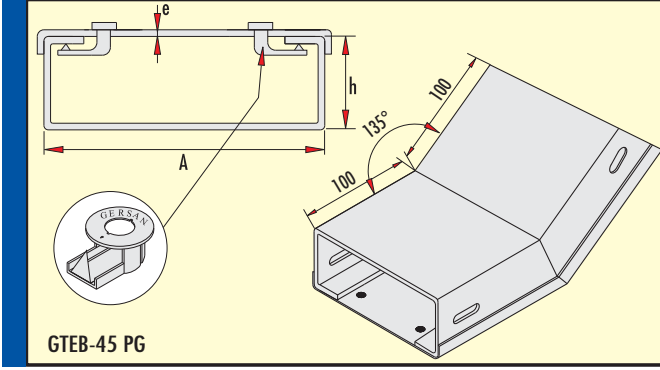

### Pregalvaniz Trunking Sistemi 45° Dış Bükey Elemanları (h=50 mm) External Bend Elements For Quick Fix Pregalvanized Cable Trunking (h=50 mm)

Внутренние Элементы Изгиба Для Предгальванизированного Кабельного Ствола 45°

Sipariş kodu Order code Код заявки	Ağırlık (Kg/ad.) Weight (Kg/unit) Вес (кг/шт)	A mm	h mm	e mm	Price list прайс-лист шт/у.е.	
					Pre-Galvanized Предв. Цинк-ия	Hot dip Galvanized гор.оцинк. HDZ
GTEB-5-45 PG	0,580	50	50	1	5,80	8,12
GTEB-7.5-45 PG	0,770	75	50	1	7,70	10,78
GTEB-10-45 PG	1,000	100	50	1	10,00	14,00
GTEB-15-45 PG	1,550	150	50	1	15,50	21,70
GTEB-20-45 PG	2,170	200	50	1	21,70	30,38

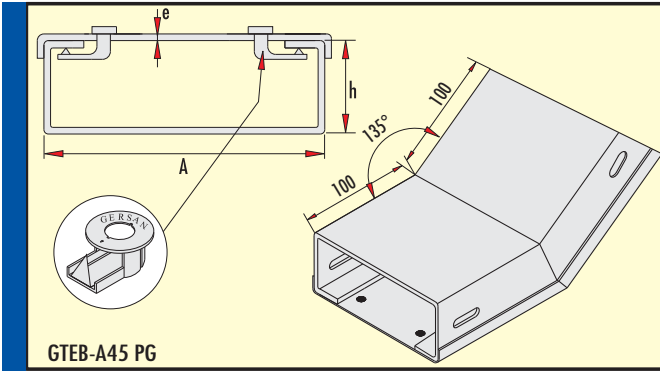

### Pregalvaniz Trunking Sistemi 45° Dış Bükey Elemanları (h=75 mm) External Bend Elements For Quick Fix Pregalvanized Cable Trunking (h=75 mm)

Внутренние Элементы Изгиба Для Предгальванизированного Кабельного Ствола 45°

Sipariş kodu Order code Код заявки	Ağırlık (Kg/ad.) Weight (Kg/unit) Вес (кг/шт)	A mm	h mm	e mm	Price list прайс-лист шт/у.е.	
					Pre-Galvanized Предв. Цинк-ия	Hot dip Galvanized гор.оцинк. HDZ
GTEB-A7.5-45 PG	0,880	75	75	1	8,80	12,32
GTEB-A10-45 PG	1,120	100	75	1	11,20	15,68
GTEB-A15-45 PG	1,660	150	75	1	16,60	23,24
GTEB-A20-45 PG	2,350	200	75	1	23,50	32,90

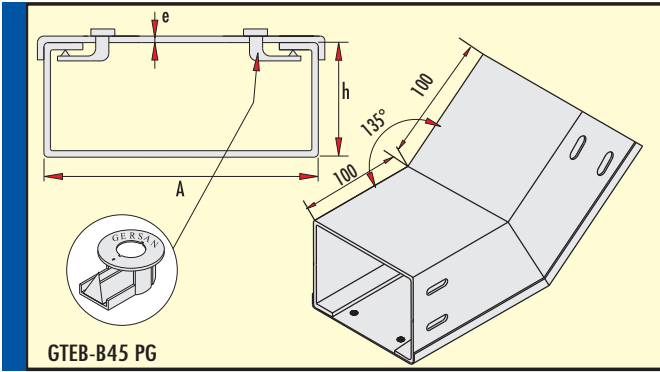

### Pregalvaniz Trunking Sistemi 45° Dış Bükey Elemanları (h=100 mm) External Bend Elements For Quick Fix Pregalvanized Cable Trunking (h=100 mm)

Внутренние Элементы Изгиба Для Предгальванизированного Кабельного Ствола 45°

Sipariş kodu Order code Код заявки	Ağırlık (Kg/ad.) Weight (Kg/unit) Вес (кг/шт)	A mm	h mm	e mm	Price list прайс-лист шт/у.е.	
					Pre-Galvanized Предв. Цинк-ия	Hot dip Galvanized гор.оцинк. HDZ
GTEB-B10-45 PG	1,250	100	100	1	12,50	17,50
GTEB-B15-45 PG	1,820	150	100	1	18,20	25,48
GTEB-B20-45 PG	2,500	200	100	1	25,00	35,00

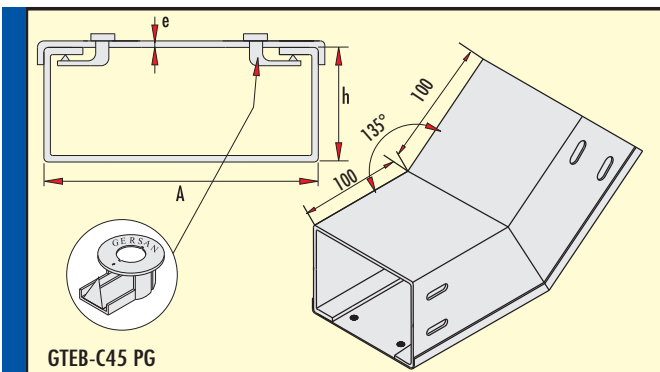

### Pregalvaniz Trunking Sistemi 45° Dış Bükey Elemanları (h=150 mm) External Bend Elements For Quick Fix Pregalvanized Cable Trunking (h=150 mm)

Внутренние Элементы Изгиба Для Предгальванизированного Кабельного Ствола 45°

Sipariş kodu Order code Код заявки	Ağırlık (Kg/ad.) Weight (Kg/unit) Вес (кг/шт)	A mm	h mm	e mm	Price list прайс-лист шт/у.е.	
					Pre-Galvanized Предв. Цинк-ия	Hot dip Galvanized гор.оцинк. HDZ
GTEB-C15-45 PG	1,820	150	150	1	18,20	25,48
GTEB-C20-45 PG	2,500	200	150	1	25,00	35,00

Bu Ürünler İsteğe Bağlı Olarak TSE 914 EN ISO 1461 (BS-EN-ISO 1461) Sıcak Daldırma Olarak İmal Edilebilir. These products can be produced from TSE 914 EN ISO 1461 (BS-EN-ISO 1461) according to the requirements.

Talep üzerine tüm ürünler RODINO 50® malzemesi ile kaplanarak (max) 400°C ısıya, asit, tuz ve kum etkilerine karşı mukavemet sağlar.

In case of required all type of materials can be coated with RODINO 50® which will give on extra resistant at effect of 400°C heat, acid, salt and sand for the material.

## PREGALVANİZ TRUNKING SİSTEMİ SONLANDIRMA ELEMANLARI

### End Cap Elements For Quick Fix Pregalvanized Cable Trunking

Элементы Кепки Конца Для Быстрого Устанавливают Предгальванизированный Кабельный Ствол

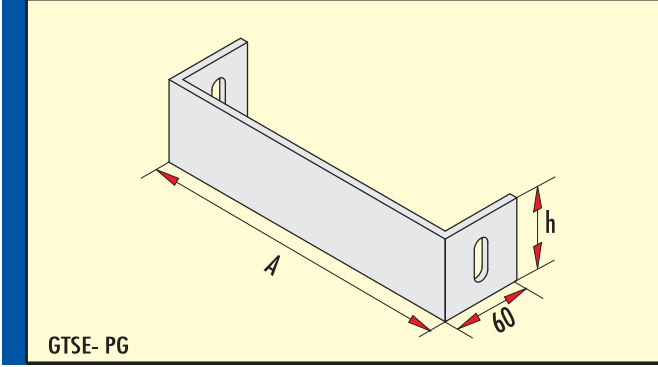

#### Pregalvaniz Trunking Sistemi Sonlandırma Elemanı

##### End Cap Elements For Quick Fix Pregalvanized Cable Trunking

Элементы Кепки Конца Для Быстрого Устанавливают Предгальванизированный Кабельный Ствол

Sipariş kodu Order code Код заявки	Ağırlık (Kg/ad.) Weight (Kg/unit) Вес (кг/шт)	A mm	h mm	e mm	Price list прайс-лист шт./y.e.	
					Pre-Galvanized Предв. Цинк-ия	Hot dip Galvanized гор.оцинк. HDZ
GTSE-5-PG	0,100	45	45	1,5	1,00	1,40
GTSE-7.5-PG	0,110	70	45	1,5	1,10	1,55
GTSE-10-PG	0,120	95	45	1,5	1,20	1,68
GTSE-15-PG	0,140	145	45	1,5	1,40	1,96
GTSE-20-PG	0,170	195	45	1,5	1,70	2,38

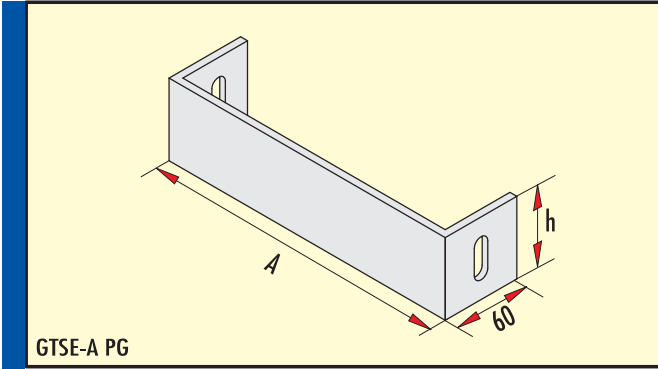

#### Pregalvaniz Trunking Sistemi Sonlandırma Elemanı

##### End Cap Elements For Quick Fix Pregalvanized Cable Trunking

Элементы Кепки Конца Для Быстрого Устанавливают Предгальванизированный Кабельный Ствол

Sipariş kodu Order code Код заявки	Ağırlık (Kg/ad.) Weight (Kg/unit) Вес (кг/шт)	A mm	h mm	e mm	Price list прайс-лист шт./y.e.	
					Pre-Galvanized Предв. Цинк-ия	Hot dip Galvanized гор.оцинк. HDZ
GTSE-A7.5-PG	0,165	70	70	1,5	1,65	2,31
GTSE-A10-PG	0,180	95	70	1,5	1,80	2,52
GTSE-A15-PG	0,220	145	70	1,5	2,20	3,08
GTSE-A20-PG	0,260	195	70	1,5	2,60	3,65

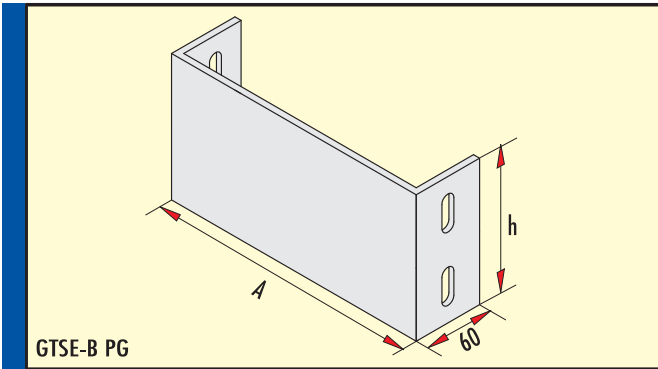

#### Pregalvaniz Trunking Sistemi Sonlandırma Elemanı

##### End Cap Elements For Quick Fix Pregalvanized Cable Trunking

Элементы Кепки Конца Для Быстрого Устанавливают Предгальванизированный Кабельный Ствол

Sipariş kodu Order code Код заявки	Ağırlık (Kg/ad.) Weight (Kg/unit) Вес (кг/шт)	A mm	h mm	e mm	Price list прайс-лист шт./y.e.	
					Pre-Galvanized Предв. Цинк-ия	Hot dip Galvanized гор.оцинк. HDZ
GTSE-B10-PG	0,250	95	95	1,5	2,50	3,50
GTSE-B15-PG	0,310	145	95	1,5	3,10	4,34
GTSE-B20-PG	0,360	195	95	1,5	3,60	5,05

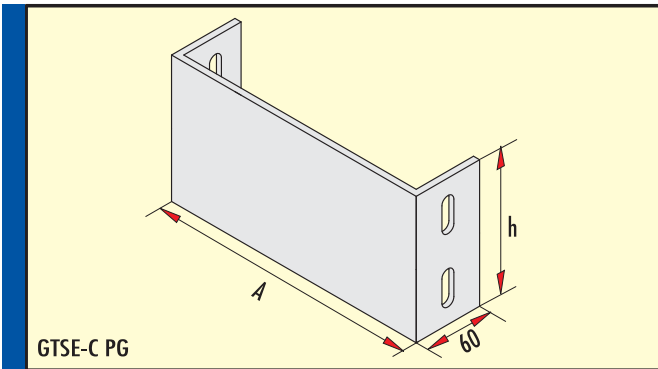

#### Pregalvaniz Trunking Sistemi Sonlandırma Elemanı

##### End Cap Elements For Quick Fix Pregalvanized Cable Trunking

Элементы Кепки Конца Для Быстрого Устанавливают Предгальванизированный Кабельный Ствол

Sipariş kodu Order code Код заявки	Ağırlık (Kg/ad.) Weight (Kg/unit) Вес (кг/шт)	A mm	h mm	e mm	Price list прайс-лист шт./y.e.	
					Pre-Galvanized Предв. Цинк-ия	Hot dip Galvanized гор.оцинк. HDZ
GTSE-C15-PG	0,470	145	145	1,5	4,70	6,60
GTSE-C20-PG	0,550	195	145	1,5	5,50	7,70

Bu Ürünler İsteğe Bağlı Olarak TSE 914 EN ISO 1461 (BS-EN-ISO 1461) Sıcak Daldırma Olarak İmal Edilebilir. These products can be produced from TSE 914 EN ISO 1461 (BS-EN-ISO 1461) according to the requirements.

Talep üzerine tüm ürünler RODINA 50® malzemesi ile kaplanarak (max) 400°C ısıya, asit, tuz ve kum etkilerine karşı mukavemet sağlar.

In case of required all type of materials can be coated with RODINA 50® which will give on extra resistant at effect of 400°C heat, acid, salt and sand for the material.

## PREGALVANİZ TRUNKING SİSTEMİ EK PARÇALARI

### Jointing Pieces For Quick Fix Pregalvanized Cable Trunking

Соединение Частей Для Быстрого Устанавливает Предгальванизированный Кабельный Ствол

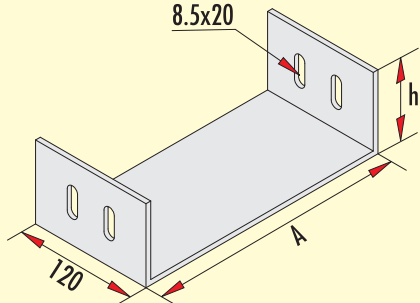

GTEP- PG

#### Pregalvaniz Trunking Sistemi Ek Parçası

##### Jointing Pieces For Quick Fix Pregalvanized Cable Trunking

Соединение Частей Для Быстрого Устанавливает Предгальванизированный Кабельный Ствол

Sipariş kodu Order code Код заявки	Ağırlık (Kg/ad.) Weight (Kg/unit) Вес (кг / шт)	A mm	h mm	e mm	Price list прайс-лист шт /у.е.	
					Pre-Galvanized Предв. Цинк-ия	Hot dip Galvanized гор.оцинк. HDZ
GTEP-5-PG	0,210	45	45	1,5	2,00	2,94
GTEP-7.5-PG	0,250	70	45	1,5	2,50	3,50
GTEP-10-PG	0,280	95	45	1,5	2,80	3,92
GTEP-15-PG	0,350	145	45	1,5	3,50	4,90
GTEP-20-PG	0,430	195	45	1,5	4,30	6,00

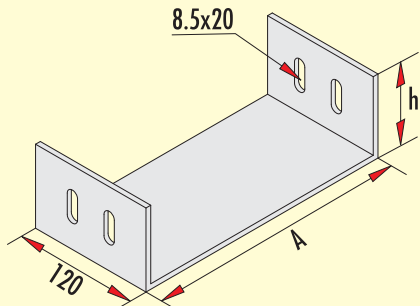

GTEP-A PG

#### Pregalvaniz Trunking Sistemi Ek Parçası

##### Jointing Pieces For Quick Fix Pregalvanized Cable Trunking

Соединение Частей Для Быстрого Устанавливает Предгальванизированный Кабельный Ствол

Sipariş kodu Order code Код заявки	Ağırlık (Kg/ad.) Weight (Kg/unit) Вес (кг / шт)	A mm	h mm	e mm	Price list прайс-лист шт /у.е.	
					Pre-Galvanized Предв. Цинк-ия	Hot dip Galvanized гор.оцинк. HDZ
GTEP-A7.5-PG	0,320	70	70	1,5	3,20	4,50
GTEP-A10-PG	0,350	95	70	1,5	3,50	4,90
GTEP-A15-PG	0,430	145	70	1,5	4,30	6,00
GTEP-A20-PG	0,495	195	70	1,5	4,95	6,93

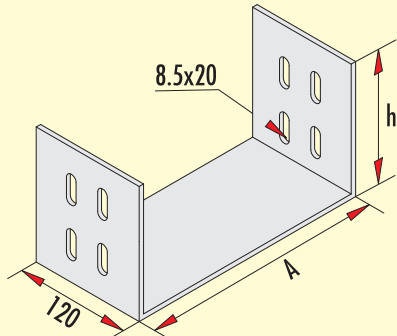

GTEP-B PG

#### Pregalvaniz Trunking Sistemi Ek Parçası

##### Jointing Pieces For Quick Fix Pregalvanized Cable Trunking

Соединение Частей Для Быстрого Устанавливает Предгальванизированный Кабельный Ствол

Sipariş kodu Order code Код заявки	Ağırlık (Kg/ad.) Weight (Kg/unit) Вес (кг / шт)	A mm	h mm	e mm	Price list прайс-лист шт /у.е.	
					Pre-Galvanized Предв. Цинк-ия	Hot dip Galvanized гор.оцинк. HDZ
GTEP-B10-PG	0,430	95	95	1,5	4,30	6,00
GTEP-B15-PG	0,500	145	95	1,5	5,00	7,00
GTEP-B20-PG	0,570	195	95	1,5	5,70	8,00

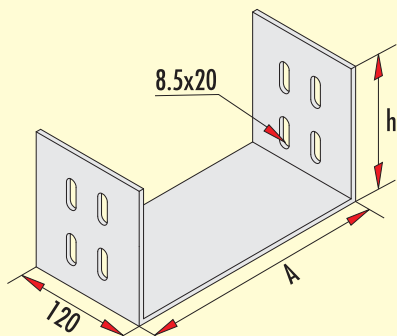

GTEP-C PG

#### Pregalvaniz Trunking Sistemi Ek Parçası

##### Jointing Pieces For Quick Fix Pregalvanized Cable Trunking

Соединение Частей Для Быстрого Устанавливает Предгальванизированный Кабельный Ствол

Sipariş kodu Order code Код заявки	Ağırlık (Kg/ad.) Weight (Kg/unit) Вес (кг / шт)	A mm	h mm	e mm	Price list прайс-лист шт /у.е.	
					Pre-Galvanized Предв. Цинк-ия	Hot dip Galvanized гор.оцинк. HDZ
GTEP-C15-PG	0,640	145	145	1,5	6,40	9,00
GTEP-C20-PG	0,715	195	145	1,5	7,15	10,00

Bu Ürünler İsteğe Bağlı Olarak TSE 914 EN ISO 1461 (BS-EN-ISO 1461) Sıcak Daldırma Olarak İmal Edilebilir. These products can be produced from TSE 914 EN ISO 1461 (BS-EN-ISO 1461) according to the requirements.

Talep üzerine tüm ürünler RODINA 50® malzemesi ile kaplanarak (max) 400°C ısıya, asit, tuz ve kum etkilerine karşı mukavemet sağlar.

In case of required all type of materials can be coated with RODINA 50® which will give on extra resistant at effect of 400°C heat, acid, salt and sand for the material.



## PREGALVANİZ TRUNKING SİSTEMİ REDÜKSİYON ELEMANLARI

Преобразователь данных Для Быстрого Устанавливает Предгальванизированный Кабельный Ствол

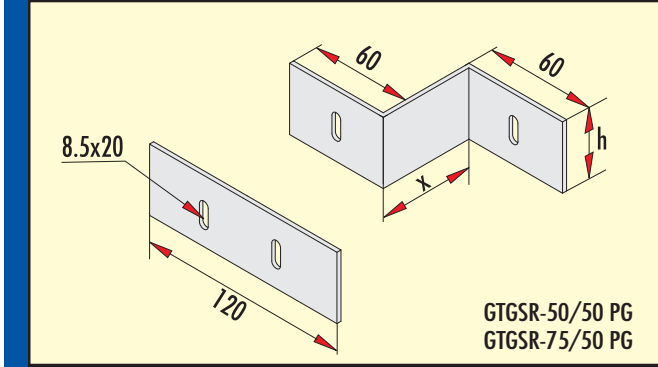

Redüksiyon X=50 mm'ye göredir

Reducer

Редуктор

Sipariş kodu Order code Код заявки	Ağırlık (Kg/ad.) Weight (Kg/unit) Вес (кг/шт)	h mm	e mm	Price list прайс-лист шт/у.е.	
				Pre-Galvanized Предв. Цинк-ия	Hot dip Galvanized гор.оцинк. HDZ
GTGSR-50/50 PG	0,150	45	1,5	1,50	2,10
GTGSR-75/50 PG	0,240	70	1,5	2,40	3,36

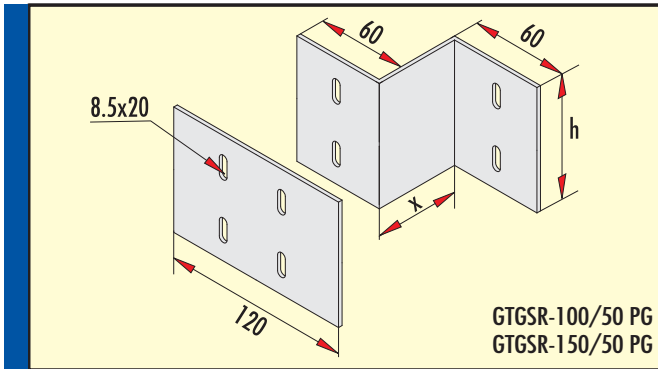

Redüksiyon X=50 mm'ye göredir

Reducer

Редуктор

Sipariş kodu Order code Код заявки	Ağırlık (Kg/ad.) Weight (Kg/unit) Вес (кг/шт)	h mm	e mm	Price list прайс-лист шт/у.е.	
				Pre-Galvanized Предв. Цинк-ия	Hot dip Galvanized гор.оцинк. HDZ
GTGSR-100/50 PG	0,330	95	1,5	3,30	4,65
GTGSR-150/50 PG	0,510	145	1,5	5,10	7,15

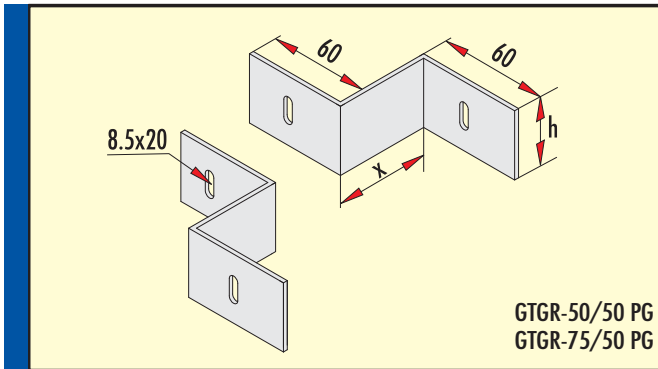

Redüksiyon X=50 mm'ye göredir

Reducer

Редуктор

Sipariş kodu Order code Код заявки	Ağırlık (Kg/ad.) Weight (Kg/unit) Вес (кг/шт)	h mm	e mm	Price list прайс-лист шт/у.е.	
				Pre-Galvanized Предв. Цинк-ия	Hot dip Galvanized гор.оцинк. HDZ
GTGR-50/50 PG	0,850	45	1,5	2,00	2,80
GTGR-75/50 PG	0,290	70	1,5	2,90	4,05

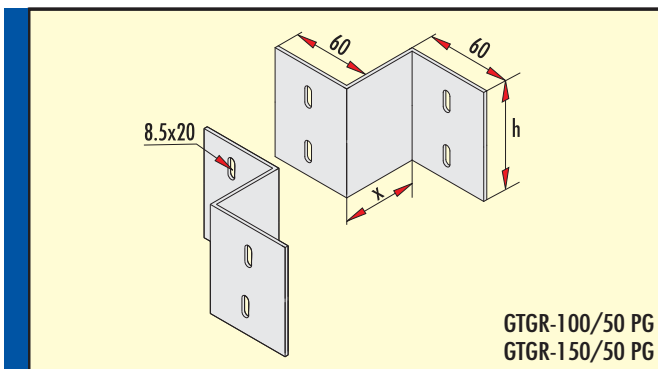

Redüksiyon X=50 mm'ye göredir

Reducer

Редуктор

Sipariş kodu Order code Код заявки	Ağırlık (Kg/ad.) Weight (Kg/unit) Вес (кг/шт)	h mm	e mm	Price list прайс-лист шт/у.е.	
				Pre-Galvanized Предв. Цинк-ия	Hot dip Galvanized гор.оцинк. HDZ
GTGR-100/50 PG	0,390	95	1,5	3,90	5,50
GTGR-150/50 PG	0,590	145	1,5	5,90	8,30

x ölçüsü değişkendir. Fiyat verilen siparişe göre belirlenecektir.

Dimension "x" variable. Price will be given due to the order

Размер «x» изменяется. Цены могут быть указаны в зависимости от заказа.

Sipariş Örneği: GTGR-50/50 PG X=50 mm

Ordering Example

Bu Ürünler İsteğe Bağlı Olarak TSE 914 EN ISO 1461(BS-EN-ISO 1461) Sıcak Daldırma Olarak İmal Edilebilir. These products can be produced from TSE 914 EN ISO 1461 (BS-EN-ISO 1461) according to the requirements.

Talep üzerine tüm ürünler RODINA 50® malzemesi ile kaplanarak (max) 400°C ısıya, asit, tuz ve kum etkilerine karşı mukavemet sağlar.

In case of required all type of materials can be coated with RODINA 50® which will give on extra resistant at effect of 400°C heat, acid, salt and sand for the material.



ÖZEL KONSOLLAR

Special Bracket

Специальные кронштейны

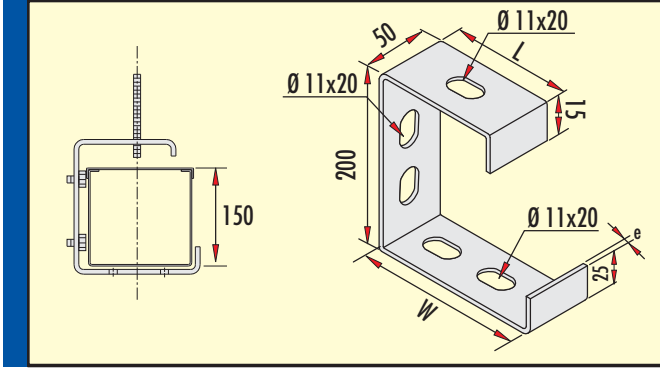

Özel Konsol Special Bracket

Специальная консоль

Sipariş kodu Order code Код заявки	Ağırlık (Kg/ad.) Weight (Kg/unit) Вес (кг/шт)	W mm	L mm	e mm	Price list прайс-лист шт/у.е.	
					Pre-Galvanized Предв. Цинк-ия	Hot dip Galvanized гор.оцинк. HDZ
GDTK/TR-B15 D	0,871	165	150	4	7,00	10,50
GDTK/TR-B20 D	1,028	215	200	4	8,20	12,30

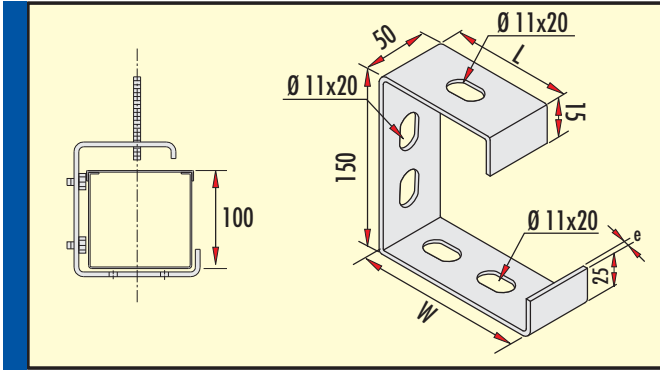

Özel Konsol Special Bracket

Специальная консоль

Sipariş kodu Order code Код заявки	Ağırlık (Kg/ad.) Weight (Kg/unit) Вес (кг/шт)	W mm	L mm	e mm	Price list прайс-лист шт/у.е.	
					Pre-Galvanized Предв. Цинк-ия	Hot dip Galvanized гор.оцинк. HDZ
GDTK/TR-B10 D	0,635	115	100	4	5,08	7,60
GDTK/TR-B15 D	0,792	165	150	4	6,30	9,50
GDTK/TR-B20 D	0,949	215	200	4	7,60	11,40

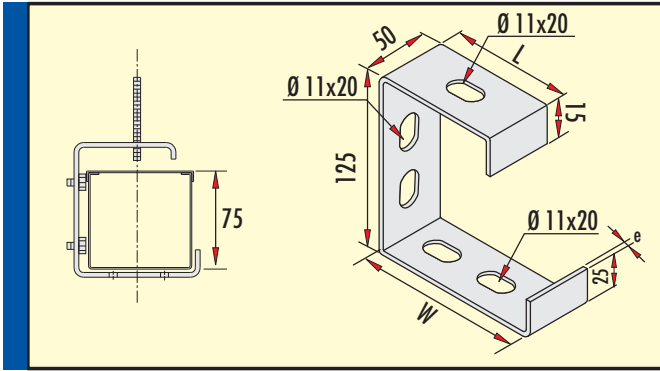

Özel Konsol Special Bracket

Специальная консоль

Sipariş kodu Order code Код заявки	Ağırlık (Kg/ad.) Weight (Kg/unit) Вес (кг/шт)	W mm	L mm	e mm	Price list прайс-лист шт/у.е.	
					Pre-Galvanized Предв. Цинк-ия	Hot dip Galvanized гор.оцинк. HDZ
GDTK/TR-A7.5D	0,338	90	75	3	2,70	4,10
GDTK/TR-A10D	0,447	115	100	3	3,60	5,40
GDTK/TR-A15D	0,565	165	150	3	4,50	6,80
GDTK/TR-A20D	0,682	215	200	3	5,50	8,20

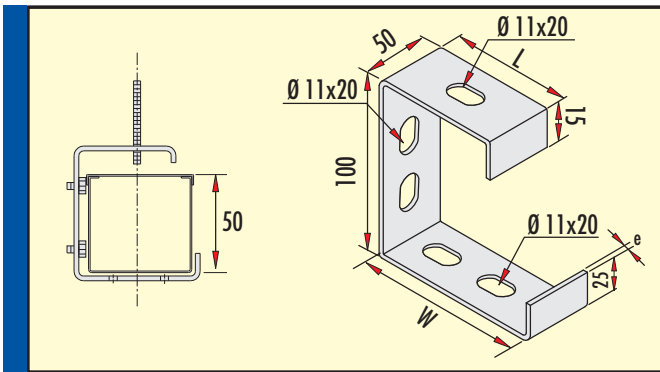

Özel Konsol Special Bracket

Специальная консоль

Sipariş kodu Order code Код заявки	Ağırlık (Kg/ad.) Weight (Kg/unit) Вес (кг/шт)	W mm	L mm	e mm	Price list прайс-лист шт/у.е.	
					Pre-Galvanized Предв. Цинк-ия	Hot dip Galvanized гор.оцинк. HDZ
GDTK/TR-5D	0,312	65	60	3	2,50	3,75
GDTK/TR-7.5D	0,359	90	75	3	2,90	4,30
GDTK/TR-10D	0,418	115	100	3	3,30	5,00
GDTK/TR-15D	0,536	165	150	3	4,30	6,40
GDTK/TR-20D	0,654	215	200	3	5,20	7,90

Kaplama : TS 914 EN ISO-1461 (BS-EN-ISO-1461) Sıcak Daldırma Galvaniz  
Coating : TS 914 EN ISO-1461 (BS-EN-ISO-1461) Hot Dip Galvanized

Bu ürünler isteğe Bağlı Olarak PREGALVANİZ ve CORTEN-A Sacdan İmal Edilebilir.  
These products can be produced from PREGALVANIZED or CORTEN-A Steel according to the requirements.

İsteğe bağlı olarak GDTK'lar açılı yapılır.

GDTK types can be produced with different angles as you may see below.

Возможно производство GDTK с разным углом по заказу.

## KABLO KANAL KAPAKLARI

## Cover For Cable Tray

## Крышки для кабельных лотков

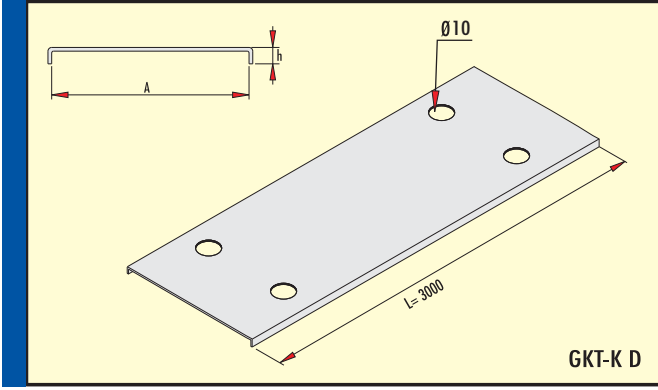

Kablo Kanal Kapağı Cover For Cable Tray						
Крышки для кабельных лотков						
Sipariş kodu Order code Код заявки	Ağırlık (Kg/mt.) Weight (Kg/mt) Вес (кг/м)	A mm	h mm	e mm	Price list прайс-лист М/у.е.	
					Pre-Galvanized Предв. Цинк-ия	Hot dip Galvanized гор.оцинк. HDZ
GKT-5K D	0,550	53	9	1	2,75	4,95
GKT-10K D	1,000	103	9	1	5,00	9,00
GKT-20K D	1,700	203	9	1	8,50	15,30
GKT-30K D	2,550	305	9	1	12,75	22,95
GKT-30-2K D	3,800	305	9	1,5	19,00	34,20
GKT-40K D	4,940	405	9	1,5	24,70	44,46
GKT-50K D	6,150	505	9	1,5	30,75	55,35
GKT-60K D	7,300	605	9	1,5	36,50	65,70

## KAPAK KELEPÇELERİ

## Cover Clamps

## Фиксаторы крышки

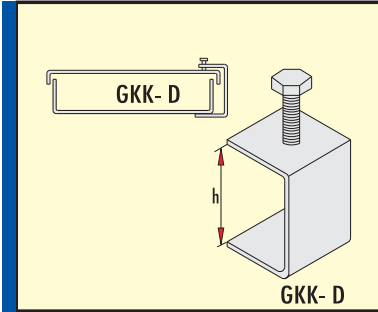

Kapak Kelepçeleri Cover Clamps						
Фиксаторы крышки						
Sipariş kodu Order code Код заявки	Ağırlık (Kg/ad.) Weight (Kg/unit) Вес (кг/шт)	h mm	e mm	Price list прайс-лист шт/у.е.		
				Pre-Galvanized Предв. Цинк-ия	Hot dip Galvanized гор.оцинк. HDZ	
GKK-45 D	0,045	45	2	0,45	0,63	
GKK-55 D	0,050	55	2	0,50	0,70	
GKK-65 D	0,055	65	2	0,60	0,84	
GKK-75 D	0,060	75	2	0,70	1,00	
GKK-105 D	0,075	105	2	0,80	1,12	

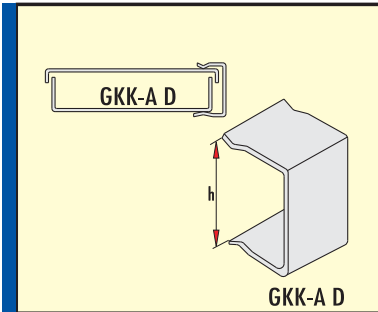
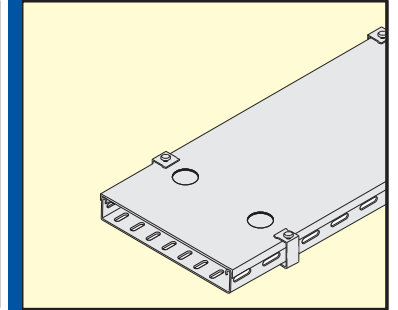

Kapak Kelepçeleri Cover Clamps						
Фиксаторы крышки						
Sipariş kodu Order code Код заявки	Ağırlık (Kg/ad.) Weight (Kg/unit) Вес (кг/шт)	h mm	e mm	Price list прайс-лист шт/у.е.		
				Pre-Galvanized Предв. Цинк-ия	Hot dip Galvanized гор.оцинк. HDZ	
GKK-A45 D	0,040	45	2	0,45	0,63	
GKK-A55 D	0,050	55	2	0,50	0,70	
GKK-A65 D	0,050	65	2	0,60	0,84	
GKK-A75 D	0,060	75	2	0,70	1,00	
GKK-A105 D	0,070	105	2	0,80	1,12	

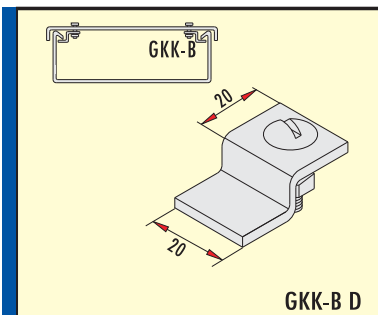
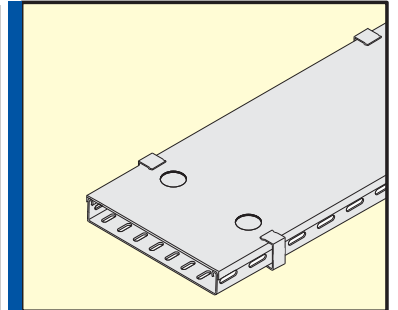

Kapak Kelepçeleri Cover Clamps						
Фиксаторы крышки						
Sipariş kodu Order code Код заявки	Ağırlık (Kg/ad.) Weight (Kg/unit) Вес (кг/шт)	h mm	e mm	Price list прайс-лист шт/у.е.		
				Pre-Galvanized Предв. Цинк-ия	Hot dip Galvanized гор.оцинк. HDZ	
GKK-B D	0,028	-	2	0,40	0,50	
GH-820 D	0,090	150	2	1,26	1,62	

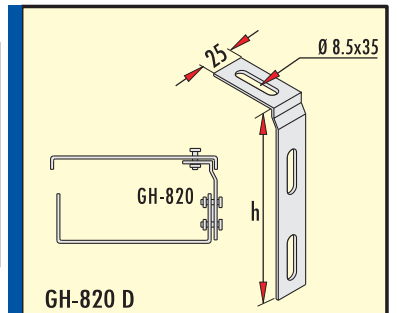

İstek üzerine "h" ölçüsü farklı imal edilebilir. Siparişlerde kapağın havalandırılmalı tip olacağı belirtilmelidir.

Dimension "h" may differ due to request. Please inform that the cover will be ventilated when ordering.

При необходимости размер «h» может изменяться при изготовлении. Пожалуйста информируйте нас при необходимости во время заказа, относительно изготовления вентиляционных отверстий на крышке

Kaplama : TS 914 EN ISO-1461 (BS-EN-ISO-1461) Sıcak Daldırma Galvaniz.

Coating : TS 914 EN ISO-1461 (BS-EN-ISO-1461) Hot Dip Galvanized

Bu Ürünler İsteğe Bağlı Olarak Pregalvaniz ve CORTEN-A Saçdan İmal Edilebilir.

These products can be produced from Pregalvanized or CORTEN-A Steel according to the requirements.

Talep üzerine tüm ürünler RODINA 50® malzemesi ile kaplanarak (max) 400°C ısıya, asit, tuz ve kum etkilerine karşı mukavemet sağlar.

In case of required all type of materials can be coated with RODINA 50® which will give on extra resistant at effect of 400°C heat, acid, salt and sand for the material.

SEPERATÖR

Separator

Сепаратор

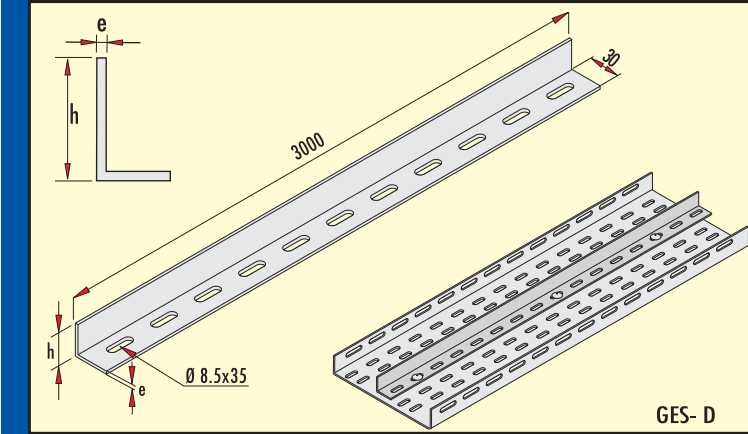

Seperatör Separator					
Сепаратор					
Sipariş kodu Order code Код заявки	Ağırlık (Kg/mt.) Weight (Kg/mt) Вес (кг/м)	h mm	e mm	Price list прайс-лист м/у.е. Pre-Galvanized Предв. Цинк-ия	Hot dip Galvanized гор.оцинк. HDZ
GES-40 D	0,530	38	1	2,65	4,77
GES-50 D	0,840	48	1,5	4,20	7,56
GES-60 D	0,950	58	1,5	4,75	8,55
GES-70 D	1,120	68	1,5	5,60	10,00
GES-100 D	2,000	98	2	10,00	18,00

SONLANDIRMA

End Cap

Наконечник

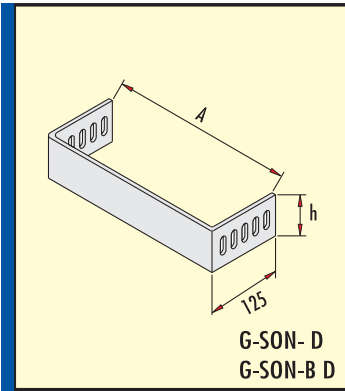

Sonlandırma End Cap						
Наконечник						
Sipariş kodu Order code Код заявки	Ağırlık (Kg/ad.) Weight (Kg/unit) Вес (кг/шт)	A mm	h mm	e mm	Price list прайс-лист шт/у.е.	
					Pre-Galvanized Предв. Цинк-ия	Hot dip Galvanized гор.оцинк. HDZ
G-SON-5D	0,100	52	40	1	0,80	1,20
G-SON-10D	0,150	102	40	1,5	1,20	1,80
G-SON-20D	0,210	202	40	1,5	1,68	2,52
G-SON-30D	0,350	302	40	2	2,80	4,20
G-SON-40D	0,400	402	40	2	3,20	4,80
G-SON-50D	0,480	502	40	2	3,84	5,76
G-SON-60D	0,550	602	40	2	4,40	6,60
G-SON-5/5 D	0,125	50	50	1	1,00	1,50
G-SON-10/5 D	0,190	100	50	1,5	1,52	2,28
G-SON-20/5 D	0,260	200	50	1,5	2,08	3,12
G-SON-30/5 D	0,440	300	50	2	3,52	5,28
G-SON-40/5 D	0,500	400	50	2	4,00	6,00
G-SON-50/5 D	0,600	500	50	2	4,80	7,20
G-SON-60/5 D	0,690	600	50	2	5,52	8,28
G-SON-B10D	0,250	102	60	1,5	2,00	3,00
G-SON-B20D	0,320	202	60	1,5	2,56	3,84
G-SON-B30D	0,500	302	60	2	4,00	6,00
G-SON-B40D	0,600	402	60	2	4,80	7,20
G-SON-B50D	0,700	502	60	2	5,60	8,40
G-SON-B60D	0,800	602	60	2	6,40	9,60

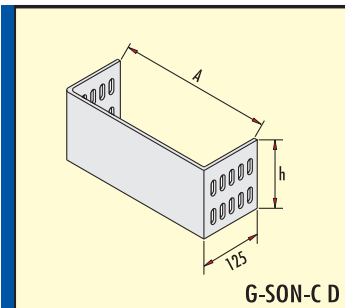
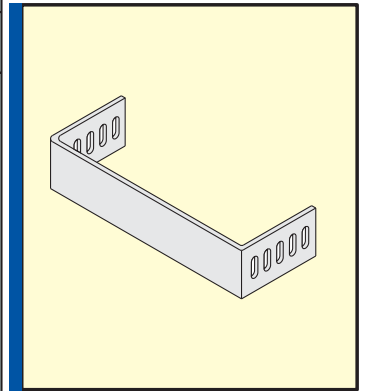

Sonlandırma End Cap						
Наконечник						
Sipariş kodu Order code Код заявки	Ağırlık (Kg/ad.) Weight (Kg/unit) Вес (кг/шт)	A mm	h mm	e mm	Price list прайс-лист шт/у.е.	
					Pre-Galvanized Предв. Цинк-ия	Hot dip Galvanized гор.оцинк. HDZ
G-SON-C10D	0,400	102	100	1,5	3,20	4,80
G-SON-C20D	0,500	202	100	1,5	4,00	6,00
G-SON-C30D	0,850	302	100	2	6,80	10,20
G-SON-C40D	1,000	402	100	2	8,00	12,00
G-SON-C50D	1,150	502	100	2	9,20	13,80
G-SON-C60D	1,300	602	100	2	10,40	15,60

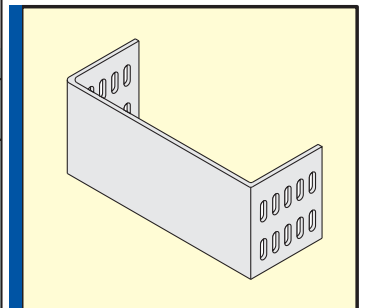

Kaplama : TS 914 EN ISO-1461 (BS-EN-ISO-1461) Sıcak Daldırma Galvaniz.  
Bu Ürünler İsteğe Bağlı Olarak Pregalvaniz ve CORTEN-A Saçdan İmal Edilebilir.

Coating : TS 914 EN ISO-1461 (BS-EN-ISO-1461) Hot Dip Galvanized  
These products can be produced from Pregalvanized or CORTEN-A Steel according to the requirements.

Talep üzerine tüm ürünler RODINA 50® malzemesi ile kaplanarak (max) 400°C ısıya, asit, tuz ve kum etkilerine karşı mukavemet sağlar.  
In case of required all type of materials can be coated with RODINA 50® which will give an extra resistant at effect of 400°C heat, acid, salt and sand for the material.



## SEVİYE AYAR ELEMANLARI

## Level Changer

Опорные элементы

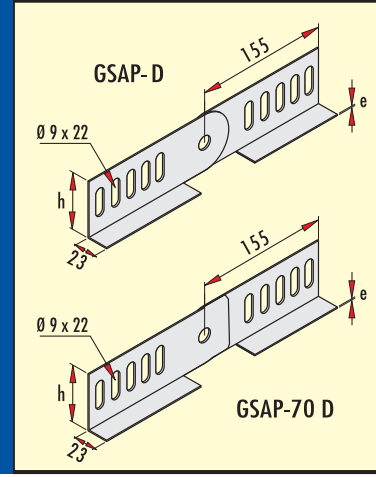

### Seviye Ayar Elemanları Level Changer

Опорные элементы

Sipariş kodu Order code Код заявки	Ağırlık (Kg/ad.) Weight (Kg/unit) Вес (кг/шт)	h mm	e mm	Price list прайс-лист шт/у.е.	
				Pre-Galvanized Предв. Цинк-ия	Hot dip Galvanized гор.оцинк. HDZ
GSAP-40 D	0,250	40	2	2,00	3,00
GSAP-50 D	0,300	50	2	2,40	3,60
GSAP-60 D	0,400	60	2	3,20	4,80
GSAP-70 D	0,600	70	2	4,80	7,20
GSAP-100 D	0,850	100	2	6,80	10,00

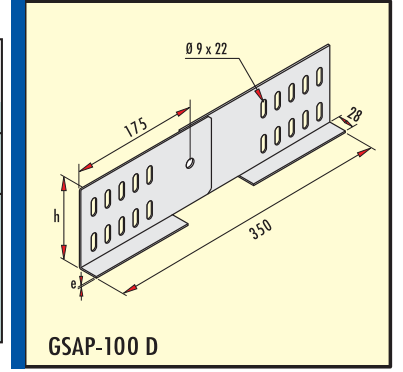

GSAP-100 D

## YÖN DEĞİŞTİRME ELEMANLARI

## Direction Changer

Соединительный элемент изменяющий направление

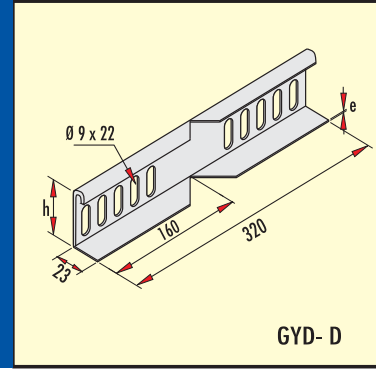

GYD-D

### Yön Değiştirme Elemanları Direction Changer

Соединительный элемент изменяющий направление

Sipariş kodu Order code Код заявки	Ağırlık (Kg/ad.) Weight (Kg/unit) Вес (кг/шт)	h mm	e mm	Price list прайс-лист шт/у.е.	
				Pre-Galvanized Предв. Цинк-ия	Hot dip Galvanized гор.оцинк. HDZ
GYD-40 D	0,300	46	2	2,40	3,60
GYD-50 D	0,400	56	2	3,20	4,80
GYD-60 D	0,450	66	2	3,60	5,40
GYD-70 D	0,500	76	2	4,00	6,00
GYD-100 D	0,600	106	2	4,80	7,20

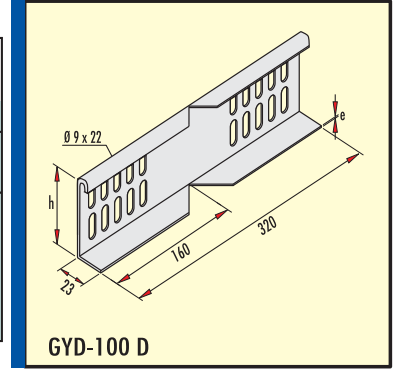

GYD-100 D

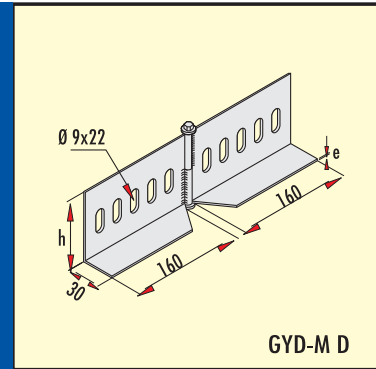

GYD-M D

### Yön Değiştirme Elemanları Direction Changer

Соединительный элемент изменяющий направление

Sipariş kodu Order code Код заявки	Ağırlık (Kg/ad.) Weight (Kg/unit) Вес (кг/шт)	h mm	e mm	Price list прайс-лист шт/у.е.	
				Pre-Galvanized Предв. Цинк-ия	Hot dip Galvanized гор.оцинк. HDZ
GYD-M40 D	0,300	40	2	2,40	3,60
GYD-M50 D	0,400	50	2	3,20	4,80
GYD-M60 D	0,450	60	2	3,60	5,40
GYD-M70 D	0,500	70	2	4,00	6,00
GYD-M100 D	0,600	100	2	4,80	7,20

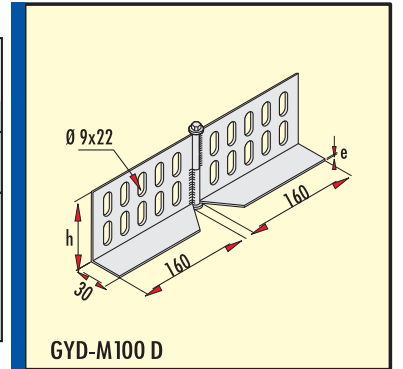

GYD-M100 D

Kaplama : TS 914 EN ISO-1461 (BS-EN-ISO-1461) Sıcak Daldırma Galvaniz.  
Bu Ürünler İsteğe Bağlı Olarak Pregalvaniz ve CORTEN-A Saçdan İmal Edilebilir.

Coating : TS 914 EN ISO-1461 (BS-EN-ISO-1461) Hot Dip Galvanized  
These products can be produced from Pregalvanized or CORTEN-A Steel according to the requirements.

Talep üzerine tüm ürünler RODINA 50® malzemesi ile kaplanarak (max) 400°C ısıya, asit, tuz ve kum etkilerine karşı mukavemet sağlar.  
In case of required all type of materials can be coated with RODINA 50® which will give on extra resistant at effect of 400°C heat, acid, salt and sand for the material.





Bergama-İZMİR/TURKEY





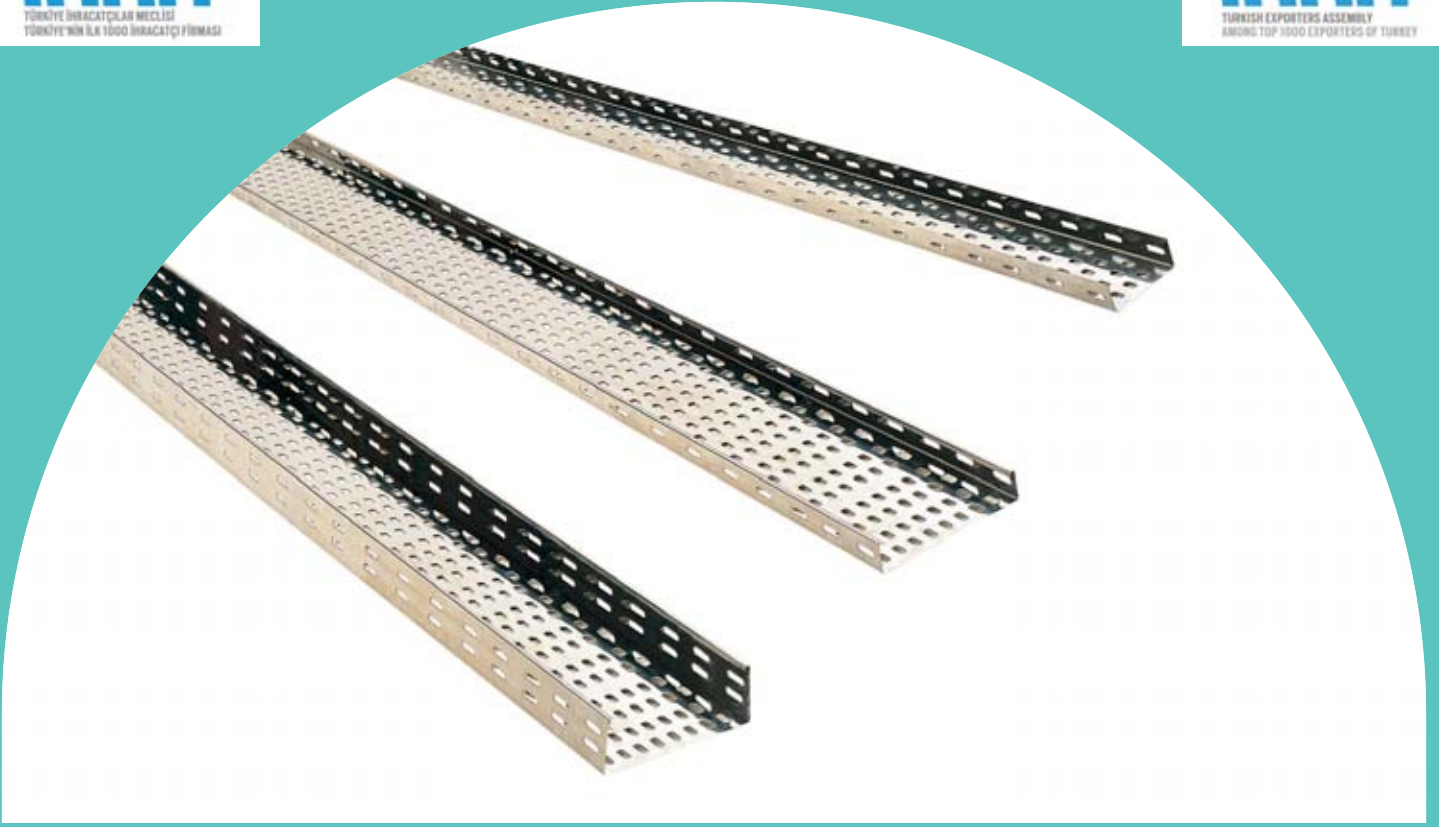

## PASLANMAZ KABLO TAŞIYICILARI

### *Stainless Steel Cable Trays*

Нержавеющая сталь Телеграфируют Подносы

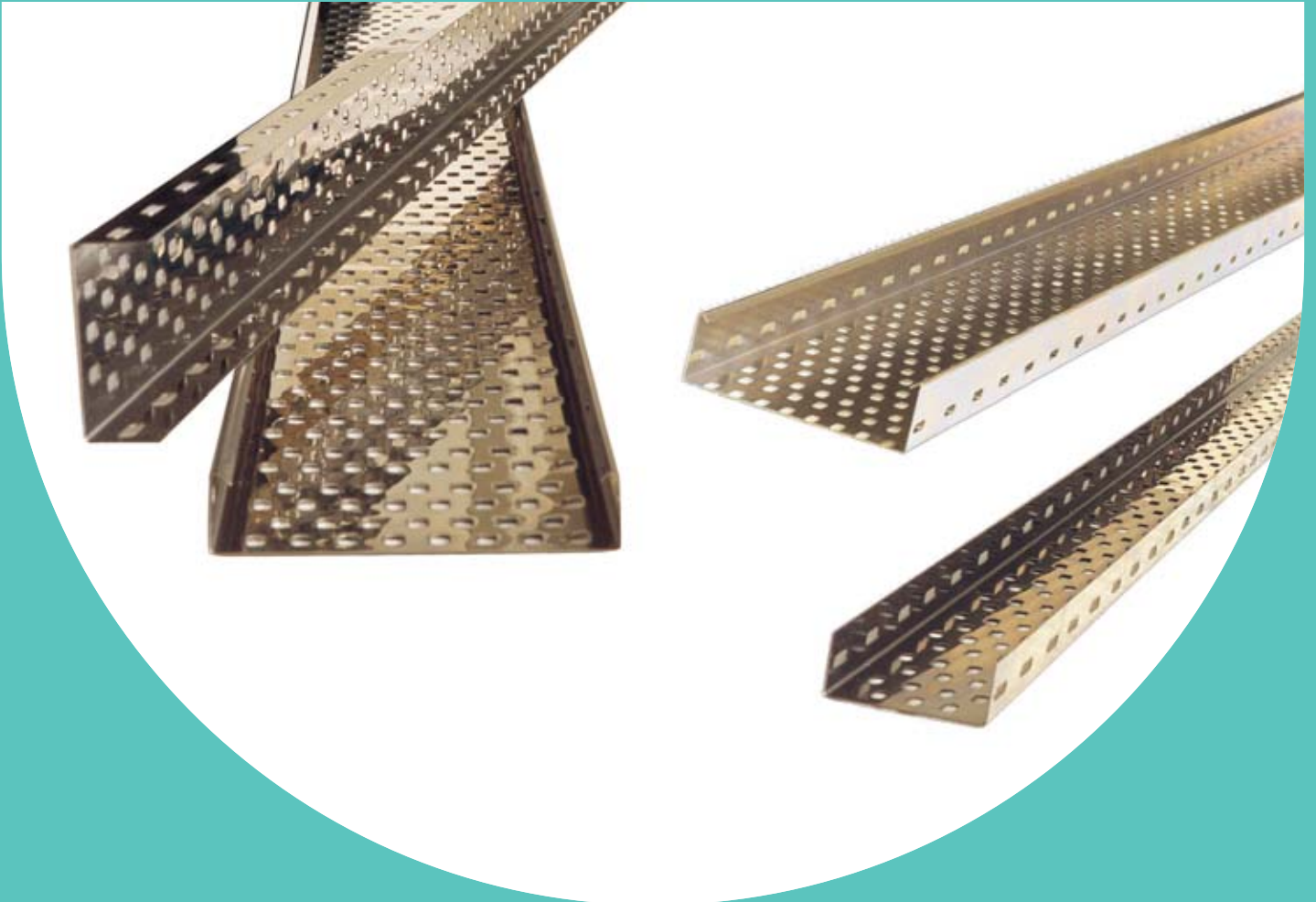

**NORMAL TİP KABLO KANALLARI**

**Normal Type Cable Trays**

Кабельные лотки нормального типа

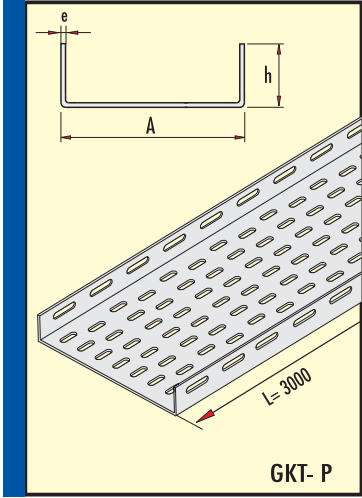

**Normal Tip Kablo Kanalı h=40 mm PASLANMAZ SAC (Cr-Ni)**  
**Normal Type Cable Tray Type h=40 Stainless Steel (Cr-Ni)**

Кабельные лотки нормального типа

Sipariş kodu Order code Код заявки	Ağırlık (Kg/mt.) Weight (Kg/mt) Вес (кг/м)	A mm	h mm	e mm	Price list прайс-лист м/у.е.
GKT-5 P	0,950	50	40	1	19,00
GKT-10-1 P	1,300	100	40	1	26,00
GKT-20 P	2,900	200	40	1,5	58,00
GKT-30-1 P	4,000	300	40	1,5	80,00
GKT-40 P	6,600	400	40	2	132,00
GKT-50 P	7,900	500	40	2	158,00
GKT-60 P	9,550	600	40	2	191,00



**DELİKSİZ KAPAKLI TİP KABLO KANALLARI**

**Non Perforated Cable Tray Type**

Кабельные лотки с крышкой.

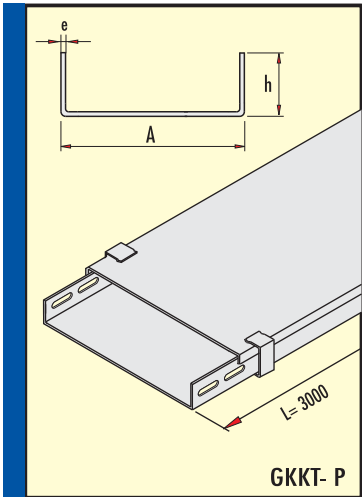

**Deliksiz Kapaklı Kablo Kanalı h=40 mm PASLANMAZ SAC (Cr-Ni)**  
**Non Perforated Cable Tray Type h=40 Stainless Steel (Cr-Ni)**

Кабельные лотки с крышкой.

Sipariş kodu Order code Код заявки	Ağırlık (Kg/mt.) Weight (Kg/mt) Вес (кг/м)	A mm	h mm	e mm	Price list прайс-лист м/у.е.
GKKT-5 P	1,700	50	40	1	34,00
GKKT-10-1 P	2,500	100	40	1	50,00
GKKT-20 P	5,300	200	40	1,5	106,00
GKKT-30-1 P	7,550	300	40	1,5	151,00
GKKT-40 P	13,500	400	40	2	270,00
GKKT-50 P	16,500	500	40	2	330,00
GKKT-60 P	19,650	600	40	2	393,00



**EK PARÇASI**

**Jointing Piece**

Соединительные элементы

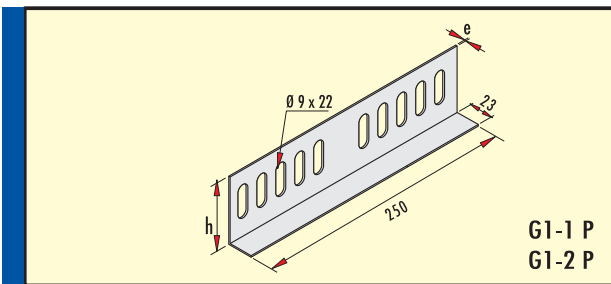

**Ek Parçası h=40 mm PASLANMAZ SAC (Cr-Ni)**  
**Jointing Piece h=40 Stainless Steel (Cr-Ni)**

Соединительные элементы

Sipariş kodu Order code Код заявки	Ağırlık (Kg/ad.) Weight (Kg/unit) Вес (кг/шт)	h mm	e mm	Price list прайс-лист шт/у.е.
G1 - 1 P	0,160	40	1,5	4,00
G1 - 2 P	0,200	40	2	5,00

Malzeme : 304-316 (SS 304-316) Kalite Paslanmaz Sac (Cr-Ni).

Bu ürünler isteğe Bağlı Olarak EN-5052 Alüminyum Alaşım Sacdan İmel Edilebilir.

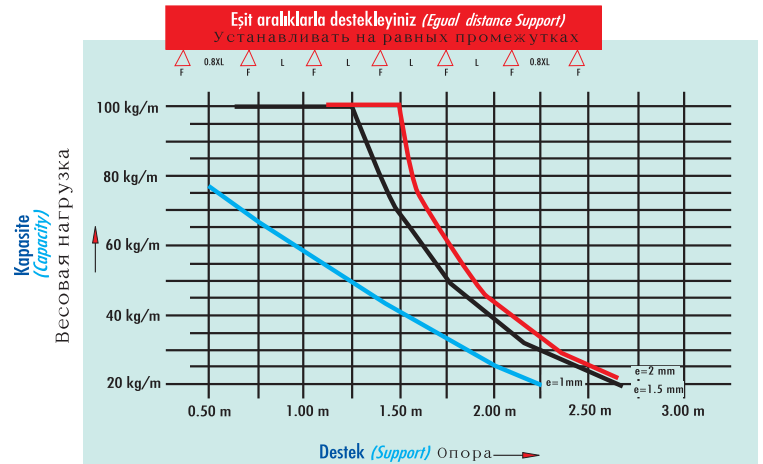

Material : 304-316 Quality (SS 304-316) Stainless Steel (Cr-Ni).

These Products Can Be Produced From Aluminium EN-5052 Steel According To The Requirements.



## DÖNÜŞ ELEMANLARI

### Flat Bends

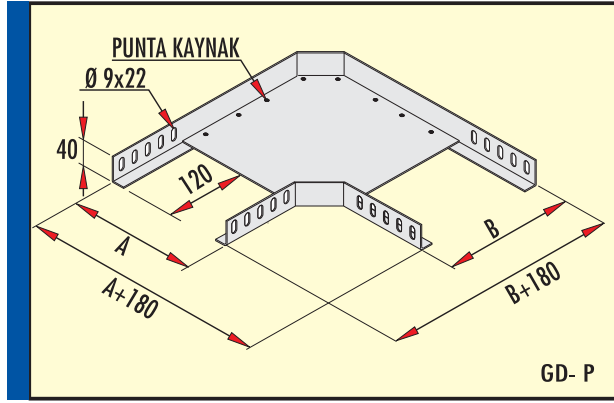

## Угловые элементы

### 90° Dönüş Elemanı h=40 mm PASLANMAZ SAC (Cr-Ni)

#### 90° Flat Bend Type h=40 Stainless Steel (Cr-Ni)

Угловые элементы 90°

Sipariş kodu Order code Код заявки	Ağırlık (Kg/ad.) Weight (Kg/unit) Вес (кг/шт)	A mm	B mm	e mm	Price list прайс-лист шт./у.е.
GD - 5 P	0,445	54	54	1	10,68
GD - 10 P	0,873	104	104	1,5	20,95
GD - 20 P	1,435	205	205	1,5	34,45
GD - 30 P	2,930	305	305	2	70,30
GD - 40 P	4,280	405	405	2	103,00
GD - 50 P	5,880	506	506	2	141,00
GD - 60 P	7,770	606	606	2	186,50

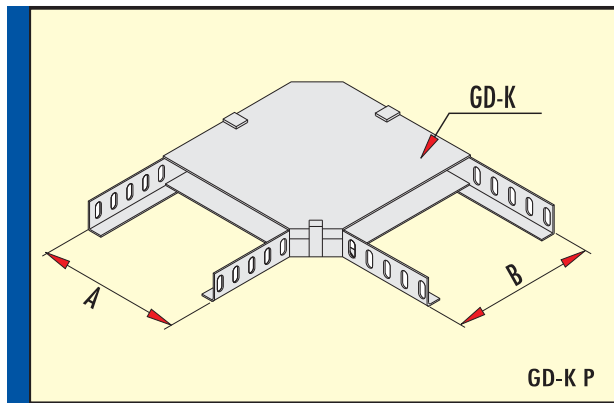

### 90° Dönüş Kapağı PASLANMAZ SAC (Cr-Ni)

#### 90° Flat Bend Cover Stainless Steel (Cr-Ni)

Крышка для угла 90°

Sipariş kodu Order code Код заявки	Ağırlık (Kg/ad.) Weight (Kg/unit) Вес (кг/шт)	A mm	B mm	e mm	Price list прайс-лист шт./у.е.
GD - 5K P	0,090	54	54	1	2,16
GD - 10K P	0,200	104	104	1	4,80
GD - 20K P	0,550	205	205	1	13,20
GD - 30K P	1,020	305	305	1	24,48
GD - 40K P	2,700	405	405	1,5	64,80
GD - 50K P	4,050	506	506	1,5	97,20
GD - 60K P	5,600	606	606	1,5	134,40

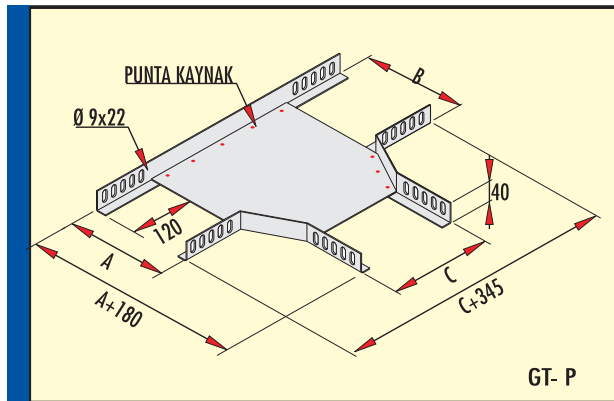

### T Bağlantı Elemanı h=40 PASLANMAZ SAC (Cr-Ni)

#### Tees "T" Stainless Steel (Cr-Ni)

«Т» образные соединительные элементы

Sipariş kodu Order code Код заявки	Ağırlık (Kg/ad.) Weight (Kg/unit) Вес (кг/шт)	A mm	B mm	C mm	e mm	Price list прайс-лист шт./у.е.
GT - 5 P	0,550	54	54	54	1	13,20
GT - 10 P	1,050	104	104	104	1,5	25,20
GT - 20 P	1,600	205	205	205	1,5	38,40
GT - 30 P	3,300	305	305	305	2	79,20
GT - 40 P	4,650	405	405	405	2	111,60
GT - 50 P	6,450	506	506	506	2	154,80
GT - 60 P	8,500	606	606	606	2	204,00

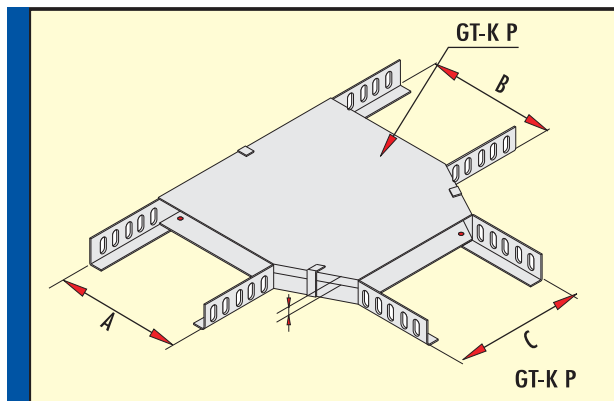

### T Bağlantı Kapağı PASLANMAZ SAC (Cr-Ni)

#### Tees "T" Cover Stainless Steel (Cr-Ni)

«Т» образные соединительные элементы

Sipariş kodu Order code Код заявки	Ağırlık (Kg/ad.) Weight (Kg/unit) Вес (кг/шт)	A mm	B mm	C mm	e mm	Price list прайс-лист шт./у.е.
GT - 5K P	0,150	54	54	54	1	3,60
GT - 10K P	0,250	104	104	104	1	6,00
GT - 20K P	0,600	205	205	205	1	14,40
GT - 30K P	1,100	305	305	305	1	26,40
GT - 40K P	2,750	405	405	405	1,5	66,00
GT - 50K P	4,000	506	506	506	1,5	96,00
GT - 60K P	5,500	606	606	606	1,5	132,00

Bu ürünler isteğe bağlı 300, 450 ve 600 Radüslü Olarak İmal Edilebilir. These products can be manufactured radius 300, 450 and radius 600 due to request.

Эти продукты могут быть изготовленным радиусом 300, 450 и радиусом 600 из-за request.

Malzeme : 304-316 (SS 304-316) Kalite Paslanmaz Sac (Cr-Ni).

Material : 304-316 Quality (SS 304-316) Stainless Steel (Cr-Ni).

Bu ürünler isteğe bağlı Olarak EN-5052 Alüminyum Alaşım Sacdan İmal Edilebilir.

These Products Can Be Produced From Aluminium EN-5052 Steel According To The Requirements.



DÖNÜŞ ELEMANLARI

Flat Bends

Угловые элементы

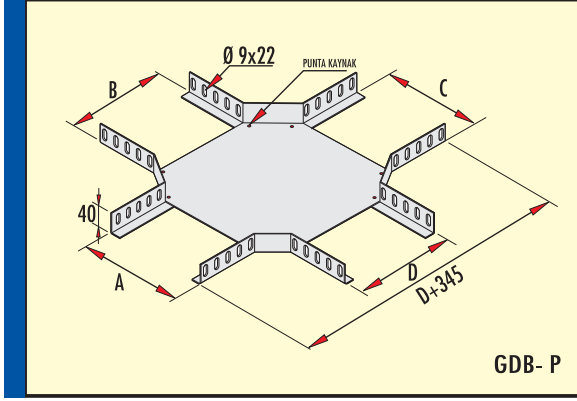

GDB - P

Dörtlü Bağlantı Elemanı h=40 mm PASLANMAZ SAC (Cr-Ni)

Crossings h=40 mm Stainless Steel (Cr-Ni)

Крестообразные соединительные элементы

Sipariş kodu Order code Код заявки	Ağırlık (Kg/ad.) Weight (Kg/unit) Вес (кг/шт)	A mm	B mm	C mm	D mm	e mm	Price list прайс-лист шт./у.е.
GDB - 5 P	0,700	54	54	54	54	1	16,80
GDB - 10 P	1,350	104	104	104	104	1,5	32,40
GDB - 20 P	1,950	205	205	205	205	1,5	46,80
GDB - 30 P	3,850	305	305	305	305	2	92,40
GDB - 40 P	5,300	405	405	405	405	2	127,20
GDB - 50 P	7,100	506	506	506	506	2	170,40
GDB - 60 P	9,300	606	606	606	606	2	223,20

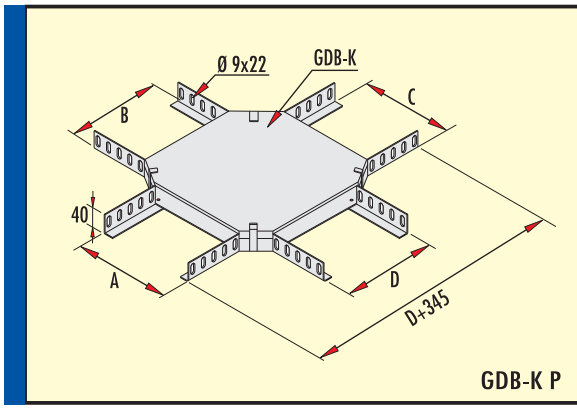

GDB-K P

Dörtlü Bağlantı Kapağı PASLANMAZ SAC (Cr-Ni)

Crossings Covers Stainless Steel (Cr-Ni)

Крестообразные соединительные элементы

Sipariş kodu Order code Код заявки	Ağırlık (Kg/ad.) Weight (Kg/unit) Вес (кг/шт)	A mm	B mm	C mm	D mm	e mm	Price list прайс-лист шт./у.е.
GDB - 5K P	0,200	54	54	54	54	1	4,80
GDB - 10K P	0,300	104	104	104	104	1	7,20
GDB - 20K P	0,700	205	205	205	205	1	16,80
GDB - 30K P	1,250	305	305	305	305	1	30,00
GDB - 40K P	2,950	405	405	405	405	1,5	70,80
GDB - 50K P	4,200	506	506	506	506	1,5	100,80
GDB - 60K P	5,700	606	606	606	606	1,5	136,80

İÇ-DIŞ BÜKEY ELEMANI VE KAPAĞI

Inside and Outside Vertical Bend and Covers

Внутри и снаружи Вертикального Изгиба и Покрытий

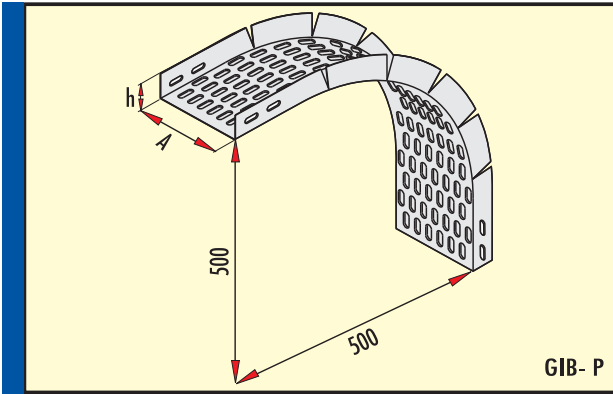

GIB - P

İç-Dış Bükey Elemanı h=40 mm PASLANMAZ SAC (Cr-Ni)

Inside and Outside Vertical Bend Stainless Steel (Cr-Ni)

Внутри и снаружи Вертикальных Изгибов

Sipariş kodu Order code Код заявки	Ağırlık (Kg/ad.) Weight (Kg/unit) Вес (кг/шт)	A mm	h mm	e mm	Price list прайс-лист шт./у.е.
GIB - 5 P	1,250	50	40	1,5	30,00
GIB - 10 P	1,750	100	40	1,5	42,00
GIB - 20 P	2,650	200	40	1,5	63,60
GIB - 30 P	4,800	300	40	2	115,20
GIB - 40 P	5,850	400	40	2	140,40
GIB - 50 P	7,150	500	40	2	171,60
GIB - 60 P	8,500	600	40	2	204,00

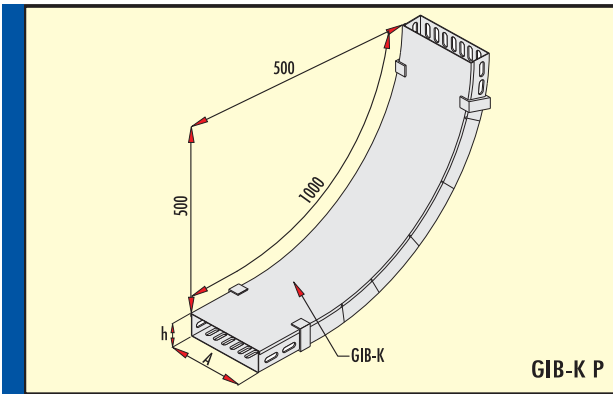

GIB-K P

İç-Dış Bükey Kapağı PASLANMAZ SAC (Cr-Ni)

Inside and Outside Vertical Bend Cover Stainless Steel (Cr-Ni)

Внутри и снаружи Вертикального Покрытия Изгиба

Sipariş kodu Order code Код заявки	Ağırlık (Kg/ad.) Weight (Kg/unit) Вес (кг/шт)	A mm	h mm	e mm	Price list прайс-лист шт./у.е.
GIB - 5K P	0,600	50	9	1	14,40
GIB - 10K P	0,950	100	9	1	22,80
GIB - 20K P	1,600	200	9	1	38,40
GIB - 30K P	2,500	300	9	1	60,00
GIB - 40K P	4,800	400	9	1,5	115,20
GIB - 50K P	6,050	500	9	1,5	145,20
GIB - 60K P	7,200	600	9	1,5	172,80

Bu Ürünler İsteğe Bağlı 300, 450 ve 600 Radüslü Olarak İmal Edilebilir. These products can be manufactured radius 300, 450 and radius 600 due to request.

Эти продукты могут быть изготовленными радиусом 300, 450 и радиусом 600 из-за request.

Malzeme : 304-316 (SS 304-316) Kalite Paslanmaz Sac (Cr-Ni).

Material : 304-316 Quality (SS 304-316) Stainless Steel (Cr-Ni).

Bu Ürünler İsteğe Bağlı Olarak EN-5052 Alüminyum Alaşım Sacdan İmal Edilebilir.

These Products Can Be Produced From Aluminium EN-5052 Steel According To The Requirements.

**AĞIR HİZMET TİPİ KABLO KANALLARI** *Heavy Duty Cable Trays*

Сверхмощные кабельные лотки

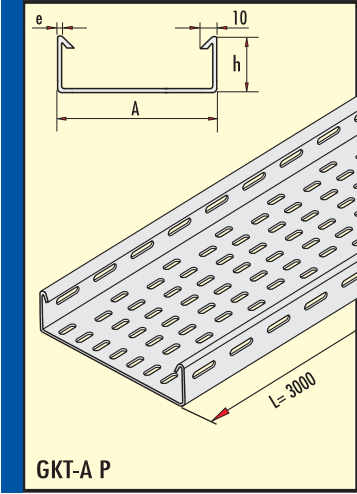

**Ağır Hizmet Tipi Kablo Kanalları (h=40) PASLANMAZ SAC (Cr-Ni)**  
*Heavy Duty Cable Tray=40 mm Stainless Steel (Cr-Ni)*

Сверхмощные кабельные лотки

Sipariş kodu Order code Код заявки	Ağırlık (Kg/mt.) Weight (Kg/mt) Вес (кг/м)	A mm	h mm	e mm	Price list прайс-лист м/у.е.
GKT-A5 P	1,100	50	40	1	22,00
GKT-A10-1 P	1,450	100	40	1	29,00
GKT-A20 P	3,300	200	40	1,5	66,00
GKT-A30-1 P	4,200	300	40	1,5	84,00
GKT-A40 P	6,850	400	40	2	137,00
GKT-A50 P	9,000	500	40	2	180,00
GKT-A60 P	10,050	600	40	2	200,00



**DELİKSİZ AĞIR HİZMET KAPAKLI TİP KABLO KANALLARI** *Non Perforated Heavy Duty Cable Trays With Cover*

Сверхмощные кабельные лотки с крышкой

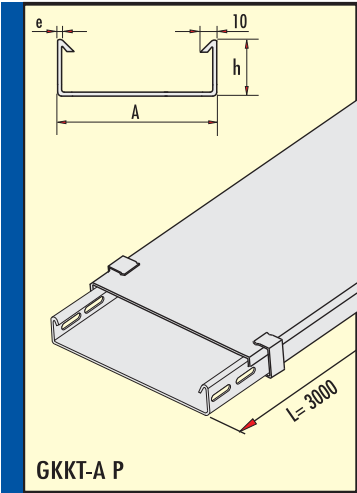

**Deliksiz Ağır Hizmet Tipi Kablo Kanalı h=40 mm PASLANMAZ SAC (Cr-Ni)**  
*Non Perforated Heavy Duty Cable Trays With Cover h=40 mm Stainless Steel (Cr-Ni)*

Сверхмощные кабельные лотки с крышкой

Sipariş kodu Order code Код заявки	Ağırlık (Kg/mt.) Weight (Kg/mt) Вес (кг/м)	A mm	h mm	e mm	Price list прайс-лист м/у.е.
GKKT-A5 P	1,900	50	40	1	38,00
GKKT-A10-1 P	2,700	100	40	1	54,00
GKKT-A20 P	5,550	200	40	1,5	111,00
GKKT-A30-1 P	7,850	300	40	1,5	157,00
GKKT-A40 P	14,000	400	40	2	280,00
GKKT-A50 P	17,000	500	40	2	340,00
GKKT-A60 P	19,950	600	40	2	400,00



**EK PARÇASI** *Joining Piece* Соединительные элементы

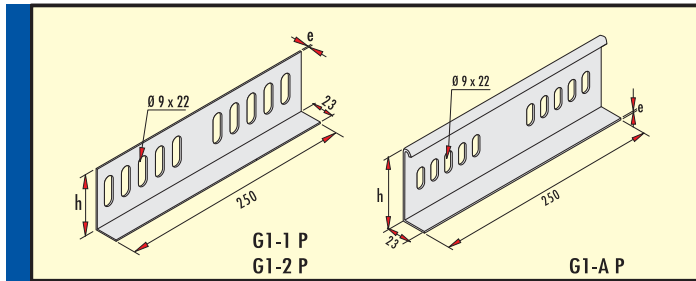

İsteğe bağlı olarak A tipi h=50 mm imal edilebilir. *A type may be produced as h=50 mm due to request.*  
при необходимости тип А может быть изготовлен с h=50 мм.

**Ek Parçası h=40 mm PASLANMAZ SAC (Cr-Ni)**  
*Joining Piece h=40 Stainless Steel (Cr-Ni)*

Соединительные элементы

Sipariş kodu Order code Код заявки	Ağırlık (Kg/ad.) Weight (Kg/unit) Вес (кг/шт)	h mm	e mm	Price list прайс-лист шт/у.е.
G1-1 P	0,160	40	1,5	4,00
G1-2 P	0,200	40	2	5,00
G1-A P	0,270	40	2	6,50

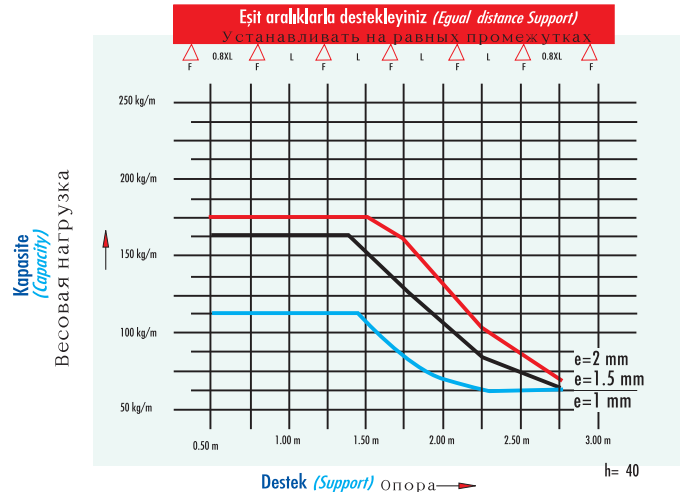

Malzeme : 304-316 (SS 304-316) Kalite Paslanmaz Sac (Cr-Ni).

Bu Ürünler İsteğe Bağlı Olarak EN-5052 Alüminyum Alaşım Sacdan İmal Edilebilir.

Material : 304-316 Quality (SS 304-316) Stainless Steel (Cr-Ni).

These Products Can Be Produced From Aluminium EN-5052 Steel According To The Requirements.

## AĞIR HİZMET DÖNÜŞ ELEMANLARI

## Heavy Duty Flat Bends

## Сверхмощные угловые элементы

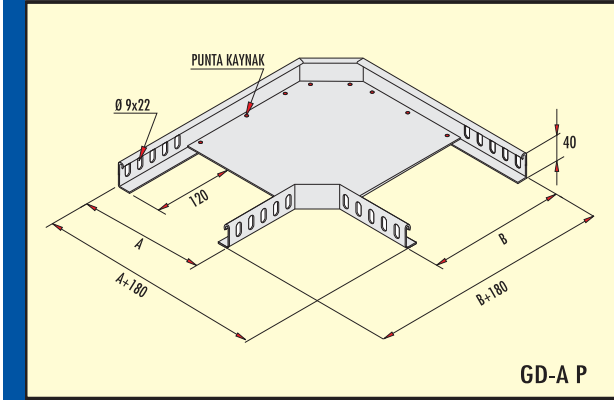

### Ağır Hizmet 90° Dönüş Elemanı h=40 mm PASLANMAZ SAC (Cr-Ni) 90° Heavy Duty Flat Bend h=40 mm Stainless Steel (Cr-Ni)

Сверхмощные угловые элементы 90°

Sipariş kodu Order code Код заявки	Ağırlık (Kg/ad.) Weight (Kg/unit) Вес (кг/шт)	A mm	B mm	e mm	Price list прайс-лист шт/у.е.
GD - A5 P	0,508	54	54	1	12,20
GD - A10 P	0,976	104	104	1,5	23,40
GD - A20 P	1,560	205	205	1,5	37,40
GD - A30 P	3,204	305	305	2	77,00
GD - A40 P	4,500	405	405	2	108,00
GD - A50 P	6,200	506	506	2	148,80
GD - A60 P	8,100	606	606	2	194,50

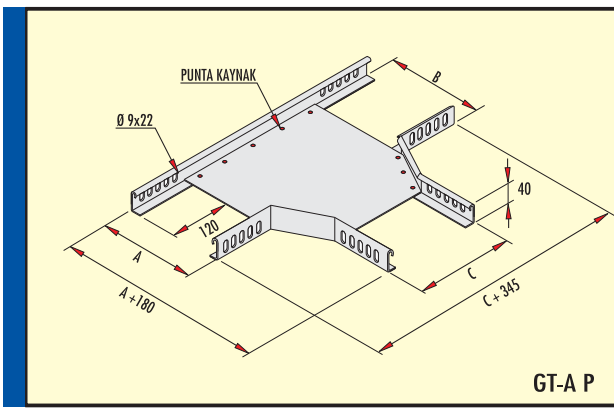

### Ağır Hizmet T Bağlantı Elemanı h=40 mm PASLANMAZ SAC (Cr-Ni) Heavy Duty Tees "T" h=40 mm Stainless Steel (Cr-Ni)

Сверхмощные «Т» образные соединительные элементы

Sipariş kodu Order code Код заявки	Ağırlık (Kg/ad.) Weight (Kg/unit) Вес (кг/шт)	A mm	B mm	C mm	e mm	Price list прайс-лист шт/у.е.
GT - A5 P	0,680	54	54	54	1	14,40
GT - A10 P	1,300	104	104	104	1,5	25,20
GT - A20 P	1,850	205	205	205	1,5	43,20
GT - A30 P	3,600	305	305	305	2	84,00
GT - A40 P	5,100	405	405	405	2	127,20
GT - A50 P	6,800	506	506	506	2	174,00
GT - A60 P	8,900	606	606	606	2	235,20

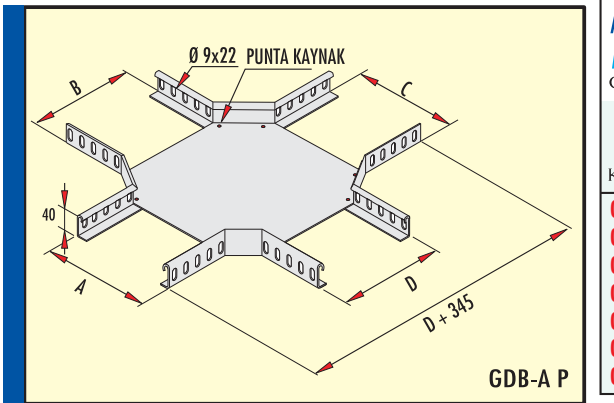

### Ağır Hizmet Dörtlü Bağlantı Elemanı h=40 mm PASLANMAZ SAC (Cr-Ni) Heavy Duty Crossing h=40 mm Stainless Steel (Cr-Ni)

Сверхмощные крестообразные соединительные элементы

Sipariş kodu Order code Код заявки	Ağırlık (Kg/ad.) Weight (Kg/unit) Вес (кг/шт)	A mm	B mm	C mm	D mm	e mm	Price list прайс-лист шт/у.е.
GDB - A5 P	0,850	54	54	54	54	1	20,40
GDB - A10 P	1,430	104	104	104	104	1,5	34,32
GDB - A20 P	2,200	205	205	205	205	1,5	52,80
GDB - A30 P	4,130	305	305	305	305	2	99,12
GDB - A40 P	5,600	405	405	405	405	2	134,40
GDB - A50 P	7,500	506	506	506	506	2	180,00
GDB - A60 P	9,600	606	606	606	606	2	230,40

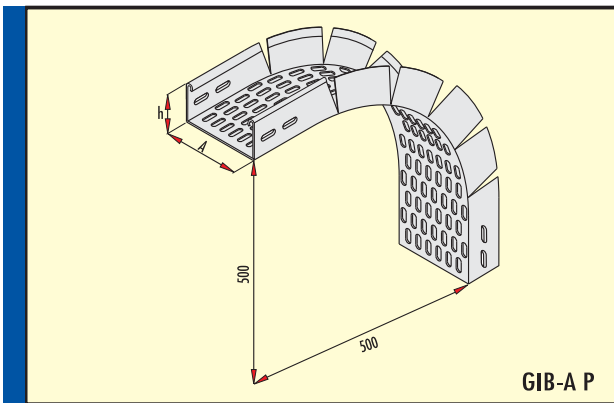

### Ağır Hizmet İç-Dış Bükey Elemanı h=40 mm PASLANMAZ SAC (Cr-Ni) Heavy Duty Inside and Outside Vertical Bend Stainless Steel (Cr-Ni)

Внутри и снаружи Вертикальных Изгибов

Sipariş kodu Order code Код заявки	Ağırlık (Kg/ad.) Weight (Kg/unit) Вес (кг/шт)	A mm	h mm	e mm	Price list прайс-лист шт/у.е.
GIB - A5 P	1,450	50	40	1,5	34,80
GIB - A10 P	1,950	100	40	1,5	46,80
GIB - A20 P	2,850	200	40	1,5	68,40
GIB - A30 P	5,050	300	40	2	121,20
GIB - A40 P	6,100	400	40	2	146,40
GIB - A50 P	7,400	500	40	2	177,60
GIB - A60 P	8,800	600	40	2	211,20

Bu Ürünler İsteğe Bağlı 300, 450 ve 600 Radiüslü Olarak İmal Edilebilir. These products can be manufactured radius 300, 450 and radius 600 due to request.  
Эти продукты могут быть изготовленным радиусом 300, 450 и радиусом 600 из-за request.

Malzeme : 304-316 (SS 304-316) Kalite Paslanmaz Sac (Cr-Ni).

Material : 304-316 Quality (SS 304-316) Stainless Steel (Cr-Ni).

Bu Ürünler İsteğe Bağlı Olarak EN-5052 Alüminyum Alaşım Sacdan İmal Edilebilir.

These Products Can Be Produced From Aluminium EN-5052 Steel According To The Requirements.



ĞİR HİZMET TİPİ KABLO KANALLARI

Heavy Duty Cable Trays

Сверхмощные кабельные лотки

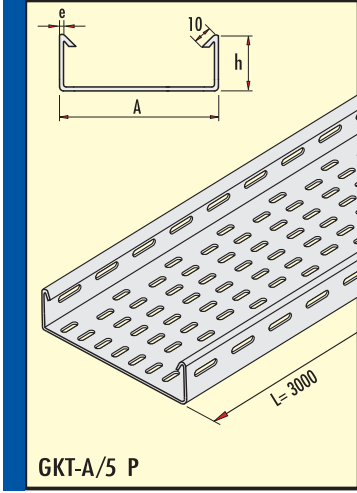

Ağır Hizmet Tipi Kablo Kanalı h=50 mm PASLANMAZ SAC (Cr-Ni)  
Heavy Duty Cable Tray h=50 mm Stainless Steel (Cr-Ni)  
Сверхмощные кабельные лотки

Sipariş kodu Order code Код заявки	Ağırlık (Kg/mt.) Weight (Kg/mt) Вес (кг/м)	A mm	h mm	e mm	Price list прайс-лист м/у.е.
GKT - A5/5 P	1,240	50	50	1	24,80
GKT - A10-1/5 P	1,540	100	50	1	30,80
GKT - A20/5 P	3,520	200	50	1,5	70,00
GKT - A30-1/5 P	4,400	300	50	1,5	88,00
GKT - A40/5 P	7,120	400	50	2	142,00
GKT - A50/5 P	9,300	500	50	2	186,00
GKT - A60/5 P	10,340	600	50	2	207,00



DELİKSİZ AĞIR HİZMET KAPAKLI TİP KABLO KANALLARI

Non Perforated Heavy Duty Cable Trays With Cover

Сверхмощные кабельные лотки с крышкой

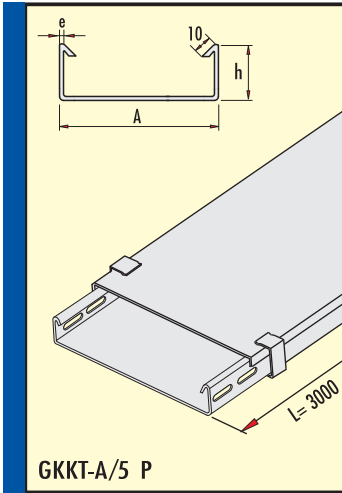

Deliksiz Ağır Hizmet Tipi Kablo Kanalı h=50 mm PASLANMAZ SAC (Cr-Ni)  
Non Perforated Heavy Duty Cable Trays With Cover h=50 mm Stainless Steel (Cr-Ni)  
Сверхмощные кабельные лотки с крышкой

Sipariş kodu Order code Код заявки	Ağırlık (Kg/mt.) Weight (Kg/mt) Вес (кг/м)	A mm	h mm	e mm	Price list прайс-лист м/у.е.
GKKT - A5/5 P	2,100	50	50	1	42,00
GKKT - A10-1/5 P	2,970	100	50	1	59,00
GKKT - A20/5 P	6,100	200	50	1,5	122,00
GKKT - A30-1/5 P	8,650	300	50	1,5	173,00
GKKT - A40/5 P	15,400	400	50	2	308,00
GKKT - A50/5 P	17,850	500	50	2	357,00
GKKT - A60/5 P	21,000	600	50	2	420,00



EK PARÇASI

Jointing Piece

Соединительные элементы

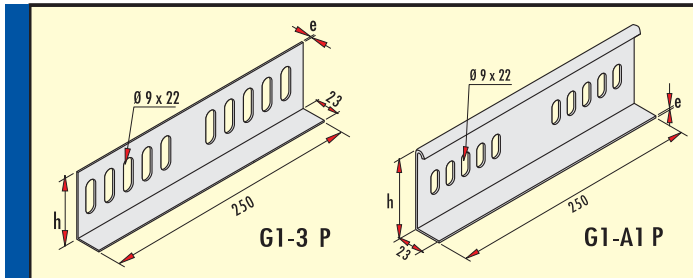

İsteğe bağlı olarak A tipi h=50 mm imal edilebilir. A type may be produced as h=50 mm due to request.  
при необходимости тип А может быть изготовлен с h=50 мм.

Ek Parçası h=50 mm PASLANMAZ SAC (Cr-Ni)  
Jointing Piece h=50 mm Stainless Steel (Cr-Ni)

Sipariş kodu Order code Код заявки	Ağırlık (Kg/ad.) Weight (Kg/unit) Вес (кг/шт)	h mm	e mm	Price list прайс-лист шт/у.е.
G1 - 3 P	0,240	50	2	5,80
G1 - A1 P	0,300	54	2	7,20

Eşit aralıklarla destekleyiniz (Equal distance Support)  
Устанавливать на равных промежутках

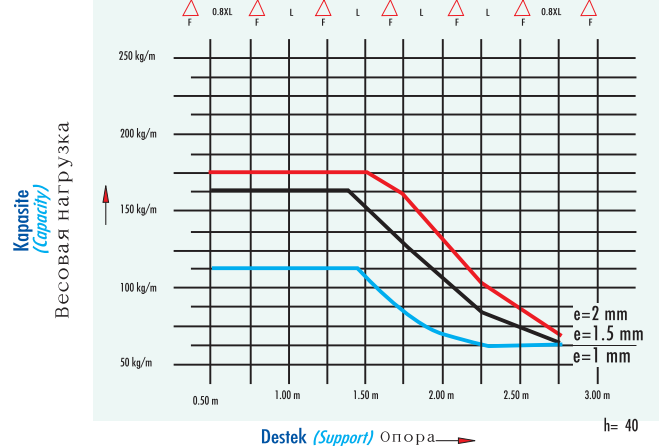

Malzeme : 304-316 (SS 304-316) Kalite Paslanmaz Sac (Cr-Ni).

Bu Ürünler İsteğe Bağlı Olarak EN-5052 Alüminyum Alaşım Sacdan İmal Edilebilir.

Material : 304-316 Quality (SS 304-316) Stainless Steel (Cr-Ni).

These Products Can Be Produced From Aluminium EN-5052 Steel According To The Requirements.

## AĞIR HİZMET DÖNÜŞ ELEMANLARI

## Heavy Duty Flat Bends

## Сверхмощные угловые элементы

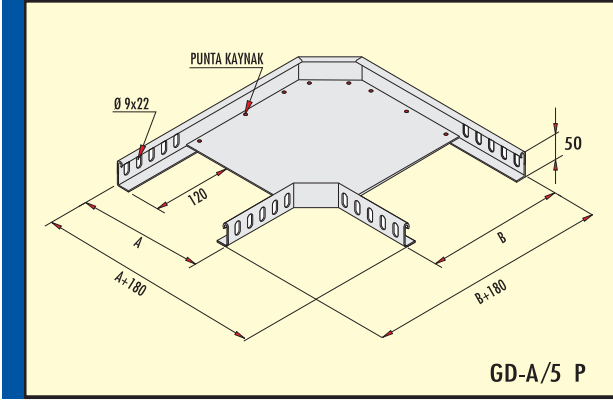

### Ağır Hizmet 90° Dönüş Elemanı h= 50 mm PASLANMAZ SAC (Cr-Ni)

### 90° Heavy Duty Flat Bend h= 50 mm Stainless Steel (Cr-Ni)

Сверхмощные угловые элементы 90°

Sipariş kodu Order code Код заявки	Ağırlık (Kg/ad.) Weight (Kg/unit) Вес (кг/шт)	A mm	B mm	e mm	Price list прайс-лист шт/у.е.
GD - A5/5 P	0,570	54	54	1	13,68
GD - A10/5 P	1,100	104	104	1,5	26,40
GD - A20/5 P	1,680	205	205	1,5	40,32
GD - A30/5 P	3,320	305	305	2	79,68
GD - A40/5 P	4,710	405	405	2	113,00
GD - A50/5 P	6,380	506	506	2	153,00
GD - A60/5 P	8,340	606	606	2	200,00

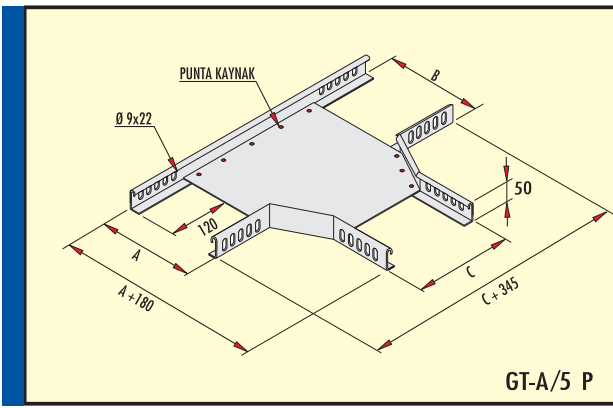

### Ağır Hizmet T Bağlantı Elemanı h= 50 mm PASLANMAZ SAC (Cr-Ni)

### Heavy Duty Tees "T" h= 50 mm Stainless Steel (Cr-Ni)

Сверхмощные «Т» образные соединительные элементы

Sipariş kodu Order code Код заявки	Ağırlık (Kg/ad.) Weight (Kg/unit) Вес (кг/шт)	A mm	B mm	C mm	e mm	Price list прайс-лист шт/у.е.
GT - A5/5 P	0,710	54	54	54	1	17,04
GT - A10/5 P	1,360	104	104	104	1,5	32,64
GT - A20/5 P	1,950	205	205	205	1,5	46,80
GT - A30/5 P	3,780	305	305	305	2	90,72
GT - A40/5 P	5,350	405	405	405	2	128,40
GT - A50/5 P	7,150	506	506	506	2	171,60
GT - A60/5 P	9,350	606	606	606	2	224,40

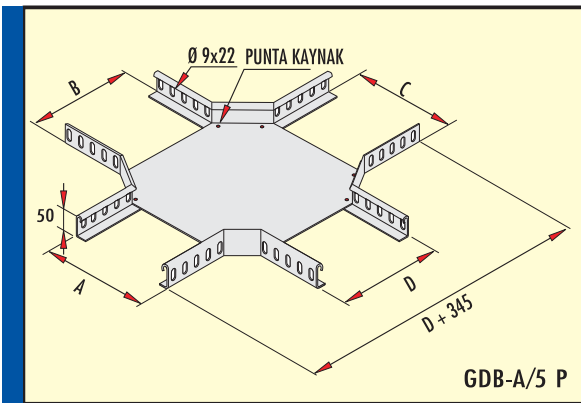

### Ağır Hizmet Dörtlü Bağlantı Elemanı h= 50 mm PASLANMAZ SAC (Cr-Ni)

### Heavy Duty Crossing h= 50 mm Stainless Steel (Cr-Ni)

Сверхмощные крестообразные соединительные элементы

Sipariş kodu Order code Код заявки	Ağırlık (Kg/ad.) Weight (Kg/unit) Вес (кг/шт)	A mm	B mm	C mm	D mm	e mm	Price list прайс-лист шт/у.е.
GDB - A5/5 P	0,90	54	54	54	54	1	21,60
GDB - A10/5 P	1,50	104	104	104	104	1,5	36,00
GDB - A20/5 P	2,30	205	205	205	205	1,5	55,20
GDB - A30/5 P	4,35	305	305	305	305	2	104,40
GDB - A40/5 P	6,95	405	405	405	405	2	166,80
GDB - A50/5 P	7,85	506	506	506	506	2	188,40
GDB - A60/5 P	10,10	606	606	606	606	2	242,40

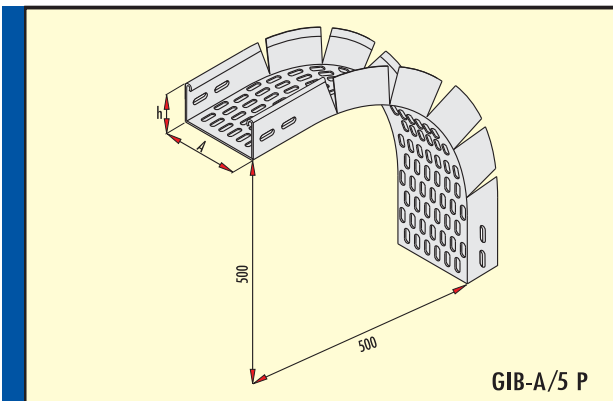

### Ağır Hizmet İç-Dış Bükey Elemanı h=50 mm PASLANMAZ SAC (Cr-Ni)

### Heavy Duty Inside and Outside Vertical Bend Stainless Steel (Cr-Ni)

Внутри и снаружи Вертикальных Изгибов

Sipariş kodu Order code Код заявки	Ağırlık (Kg/ad.) Weight (Kg/unit) Вес (кг/шт)	A mm	h mm	e mm	Price list прайс-лист шт/у.е.
GIB - A5/5 P	1,650	50	50	1,5	39,60
GIB - A10/5 P	2,150	100	50	1,5	51,60
GIB - A20/5 P	3,050	200	50	1,5	73,20
GIB - A30/5 P	5,300	300	50	2	127,50
GIB - A40/5 P	6,350	400	50	2	152,50
GIB - A50/5 P	7,650	500	50	2	183,60
GIB - A60/5 P	9,100	600	50	2	218,50

Bu Ürünler İsteğe Bağlı 300, 450 ve 600 Radüslü Olarak İmal Edilebilir. These products can be manufactured radius 300, 450 and radius 600 due to request.

Эти продукты могут быть изготовленными радиусом 300, 450 и радиусом 600 из-за request.

Malzeme : 304-316 (SS 304-316) Kalite Paslanmaz Sac (Cr-Ni).

Material : 304-316 Quality (SS 304-316) Stainless Steel (Cr-Ni).

Bu Ürünler İsteğe Bağlı Olarak EN-5052 Alüminyum Alaşım Sacdan İmal Edilebilir.

These Products Can Be Produced From Aluminium EN-5052 Steel According To The Requirements.

## AĞIR HİZMET TİPİ KABLO KANALLARI

## Heavy Duty Cable Trays

Сверхмощные кабельные лотки

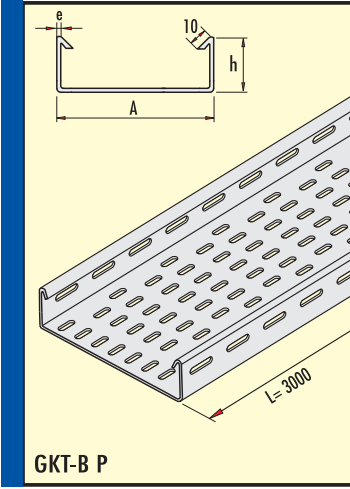

### Ağır Hizmet Tipi Kablo Kanalı h=60 mm PASLANMAZ SAC (Cr-Ni)

### Heavy Duty Cable Tray h=60 mm Stainless Steel (Cr-Ni)

Сверхмощные кабельные лотки

Sipariş kodu Order code Код заявки	Ağırlık (Kg/mt.) Weight (Kg/mt) Вес (кг/м)	A mm	h mm	e mm	Price list прайс-лист м/у.е.
GKT - B5 P	1,40	50	60	1	28,00
GKT - B10 P	2,60	100	60	1,5	52,00
GKT - B20 P	3,75	200	60	1,5	75,00
GKT - B30-1P	4,65	300	60	1,5	93,00
GKT - B40 P	7,50	400	60	2	150,00
GKT - B50 P	9,20	500	60	2	184,00
GKT - B60 P	10,60	600	60	2	212,00

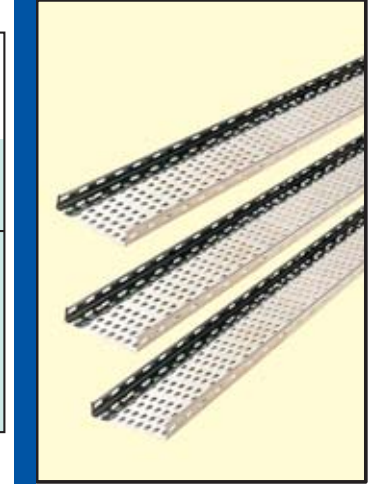

## DELİKSİZ AĞIR HİZMET KAPAKLI TİP KABLO KANALLARI

Сверхмощные кабельные лотки с крышкой

## Non Perforated Heavy Duty Cable Trays With Cover

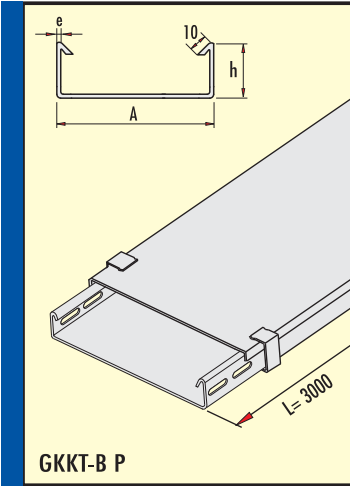

### Deliksiz Ağır Hizmet Tipi Kablo Kanalı h=60 mm PASLANMAZ SAC (Cr-Ni)

### Non Perforated Heavy Duty Cable Trays With Cover h=60 mm Stainless Steel (Cr-Ni)

Сверхмощные кабельные лотки с крышкой

Sipariş kodu Order code Код заявки	Ağırlık (Kg/mt.) Weight (Kg/mt) Вес (кг/м)	A mm	h mm	e mm	Price list прайс-лист м/у.е.
GKKT - B5 P	2,100	50	60	1	42,00
GKKT - B10 P	4,150	100	60	1,5	83,00
GKKT - B20 P	5,650	200	60	1,5	113,00
GKKT - B30 1 P	8,400	300	60	1,5	168,00
GKKT - B40 P	14,700	400	60	2	294,00
GKKT - B50 P	17,700	500	60	2	354,00
GKKT - B60 P	20,700	600	60	2	414,00



## EK PARÇASI

## Jointing Piece

Соединительные элементы

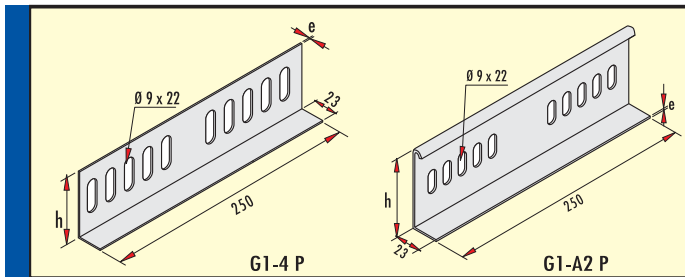

### Ek Parçası h=60 mm PASLANMAZ SAC (Cr-Ni)

### Jointing Piece h=60 Stainless Steel (Cr-Ni)

Соединительные элементы

Sipariş kodu Order code Код заявки	Ağırlık (Kg/ad.) Weight (Kg/unit) Вес (кг/шт)	h mm	e mm	Price list прайс-лист шт/у.е.
G1 - 4 P	0,270	60	2	6,50
G1 - A2 P	0,330	64	2	8,00

Malzeme : 304-316 (SS 304-316) Kalite Paslanmaz Sac (Cr-Ni).

Bu Ürünler İsteğe Bağlı Olarak EN-5052 Alüminyum Alaşım Sacdan İmal Edilebilir.

Material : 304-316 Quality (SS 304-316) Stainless Steel (Cr-Ni).

These Products Can Be Produced From Aluminium EN-5052 Steel According To The Requirements.

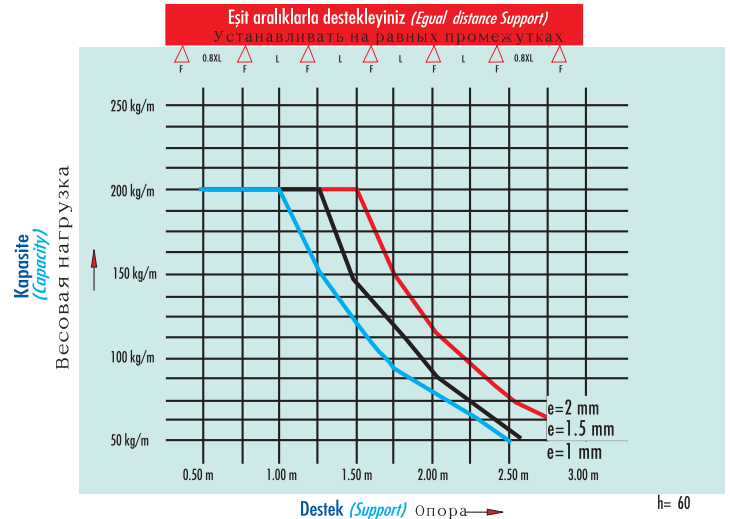

AĞIR HİZMET DÖNÜŞ ELEMANLARI

Heavy Duty Flat Bends

Сверхмощные угловые элементы

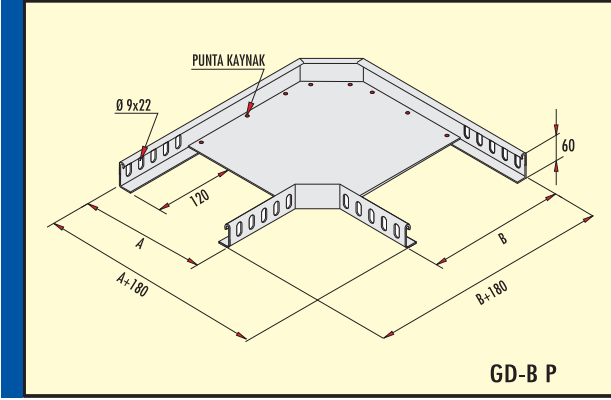

Ağır Hizmet 90° Dönüş Elemanı h=60 mm PASLANMAZ SAC (Cr-Ni)

90° Heavy Duty Flat Bend h=60 mm Stainless Steel (Cr-Ni)

Сверхмощные угловые элементы 90°

Sipariş kodu Order code Код заявки	Ağırlık (Kg/ad.) Weight (Kg/unit) Вес (кг/шт)	A mm	B mm	e mm	Price list прайс-лист шт./у.е.
GD - B5 P	0,631	54	54	1	15,15
GD - B10 P	1,184	104	104	1,5	28,50
GD - B20 P	1,810	205	205	1,5	43,44
GD - B30 P	3,524	305	305	2	84,50
GD - B40 P	5,000	405	405	2	120,00
GD - B50 P	6,650	506	506	2	160,00
GD - B60 P	8,624	606	606	2	207,00

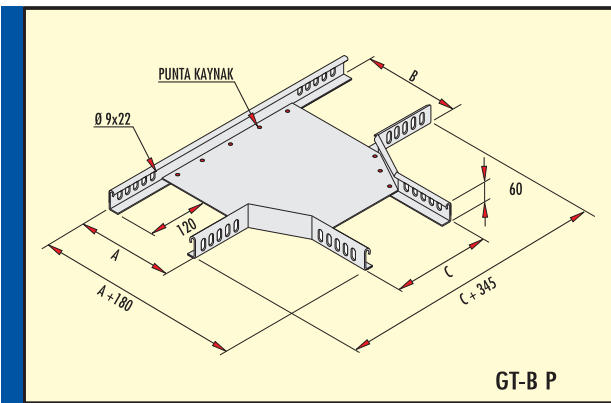

Ağır Hizmet T Bağlantı Elemanı h=60 mm PASLANMAZ SAC (Cr-Ni)

Heavy Duty Tees "T" h=60 mm Stainless Steel (Cr-Ni)

Сверхмощные «Т» образные соединительные элементы

Sipariş kodu Order code Код заявки	Ağırlık (Kg/ad.) Weight (Kg/unit) Вес (кг/шт)	A mm	B mm	C mm	e mm	Price list прайс-лист шт./у.е.
GT - B5 P	1,200	54	54	54	1	28,80
GT - B10 P	1,500	104	104	104	1,5	36,00
GT - B20 P	2,100	205	205	205	1,5	50,40
GT - B30 P	4,250	305	305	305	2	102,00
GT - B40 P	5,450	405	405	405	2	130,80
GT - B50 P	7,250	506	506	506	2	174,00
GT - B60 P	9,350	606	606	606	2	224,40

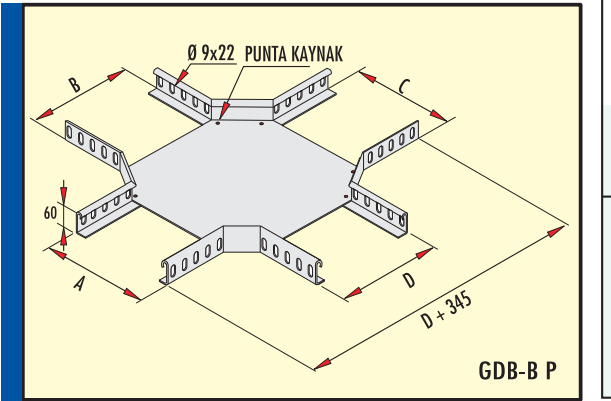

Ağır Hizmet Dörtlü Bağlantı Elemanı h=60 mm PASLANMAZ SAC (Cr-Ni)

Heavy Duty Crossing h=60 mm Stainless Steel (Cr-Ni)

Сверхмощные крестообразные соединительные элементы

Sipariş kodu Order code Код заявки	Ağırlık (Kg/ad.) Weight (Kg/unit) Вес (кг/шт)	A mm	B mm	C mm	D mm	e mm	Price list прайс-лист шт./у.е.
GDB - B5 P	1,400	54	54	54	54	1	33,60
GDB - B10 P	1,880	104	104	104	104	1,5	45,12
GDB - B20 P	2,500	205	205	205	205	1,5	60,00
GDB - B30 P	4,400	305	305	305	305	2	105,60
GDB - B40 P	6,000	405	405	405	405	2	144,00
GDB - B50 P	7,850	506	506	506	506	2	188,40
GDB - B60 P	10,000	606	606	606	606	2	240,00

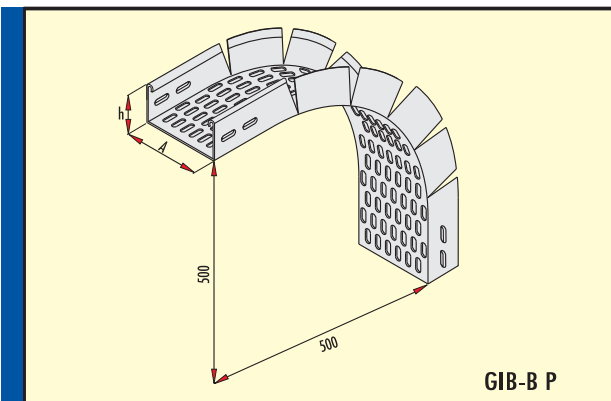

Ağır Hizmet İç-Dış Bükey Elemanı h=60 mm PASLANMAZ SAC (Cr-Ni)

Heavy Duty Inside and Outside Vertical Bend h=60 mm Stainless Steel (Cr-Ni)

Внутри и снаружи Вертикальных Изгибов

Sipariş kodu Order code Код заявки	Ağırlık (Kg/ad.) Weight (Kg/unit) Вес (кг/шт)	A mm	h mm	e mm	Price list прайс-лист шт./у.е.
GIB - B5 P	1,900	50	60	1	45,60
GIB - B10 P	2,600	100	60	1,5	62,40
GIB - B20 P	3,500	200	60	1,5	84,00
GIB - B30 P	5,750	300	60	2	138,00
GIB - B40 P	6,750	400	60	2	162,00
GIB - B50 P	8,250	500	60	2	198,00
GIB - B60 P	9,600	600	60	2	230,40

Bu Ürünler İsteğe Bağlı 300, 450 ve 600 Radüslü Olarak İmal Edilebilir. These products can be manufactured radius 300, 450 and radius 600 due to request.

Эти продукты могут быть изготовленными радиусом 300, 450 и радиусом 600 из-за request.

Malzeme : 304-316 (SS 304-316) Kalite Paslanmaz Sac (Cr-Ni).

Material : 304-316 Quality (SS 304-316) Stainless Steel (Cr-Ni).

Bu Ürünler İsteğe Bağlı Olarak EN-5052 Alüminyum Alaşım Sacdan İmal Edilebilir.

These Products Can Be Produced From Aluminium EN-5052 Steel According To The Requirements.



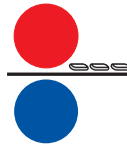

## AĞIR HİZMET TİPİ KABLO KANALLARI

## Heavy Duty Cable Trays

Сверхмощные кабельные лотки

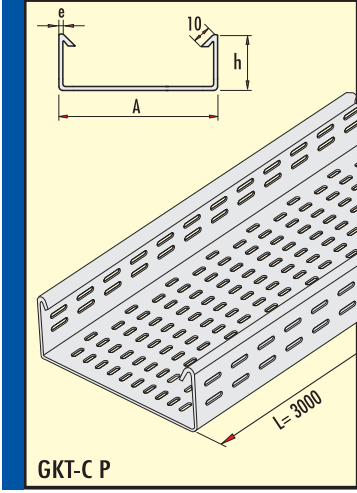

### Ağır Hizmet Tipi Kablo Kanalı h=100 mm PASLANMAZ SAC (Cr-Ni)

### Heavy Duty Cable Tray h=100 mm Stainless Steel (Cr-Ni)

Сверхмощные кабельные лотки

Sipariş kodu Order code Код заявки	Ağırlık (Kg/mt.) Weight (Kg/mt) Вес (кг/м)	A mm	h mm	e mm	Price list прайс-лист м/у.е.
GKT - C10 P	3,600	100	100	1,5	72,00
GKT - C20 P	4,500	200	100	1,5	90,00
GKT - C30 P	7,550	300	100	2	151,00
GKT - C40 P	8,800	400	100	2	176,00
GKT - C50 P	10,200	500	100	2	204,00
GKT - C60 P	11,900	600	100	2	238,00



## DELİKSİZ AĞIR HİZMET KAPAKLI TİP KABLO KANALLARI

## Non Perforated Heavy Duty Cable Trays With Cover

Сверхмощные кабельные лотки с крышкой

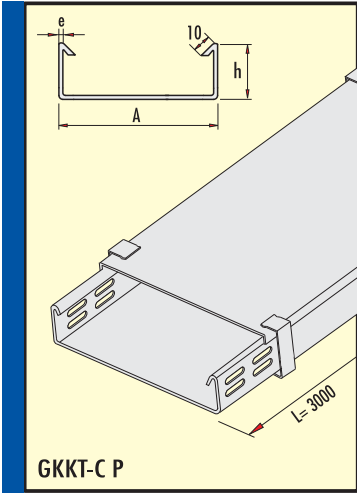

### Deliksiz Ağır Hizmet Tipi Kablo Kanalı h=100 mm PASLANMAZ SAC (Cr-Ni)

### Non Perforated Heavy Duty Cable Trays With Cover h=100 mm Stainless Steel (Cr-Ni)

Сверхмощные кабельные лотки с крышкой

Sipariş kodu Order code Код заявки	Ağırlık (Kg/mt.) Weight (Kg/mt) Вес (кг/м)	A mm	h mm	e mm	Price list прайс-лист м/у.е.
GKKT-C10 P	5,000	100	100	1,5	100,00
GKKT-C20 P	6,350	200	100	1,5	127,00
GKKT-C30 P	11,550	300	100	2	230,00
GKKT-C40 P	15,900	400	100	2	318,00
GKKT-C50 P	19,100	500	100	2	382,00
GKKT-C60 P	22,200	600	100	2	444,00



## EK PARÇASI

## Jointing Piece

Соединительные элементы

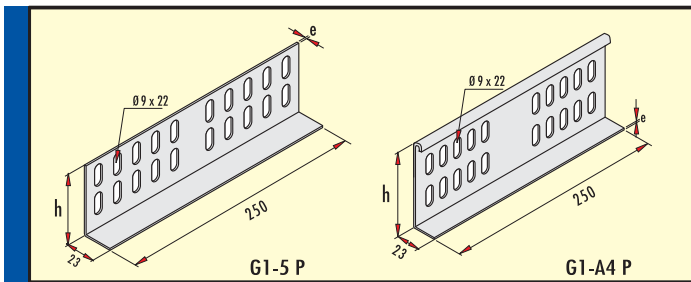

### Ek Parçası h=100 mm PASLANMAZ SAC (Cr-Ni)

### Jointing Piece h=100 Stainless Steel (Cr-Ni)

Соединительные элементы

Sipariş kodu Order code Код заявки	Ağırlık (Kg/ad.) Weight (Kg/unit) Вес (кг/шт)	h mm	e mm	Price list прайс-лист шт/у.е.
G1 - 5 P	0,420	100	2	10,00
G1 - A4 P	0,560	104	2	13,00

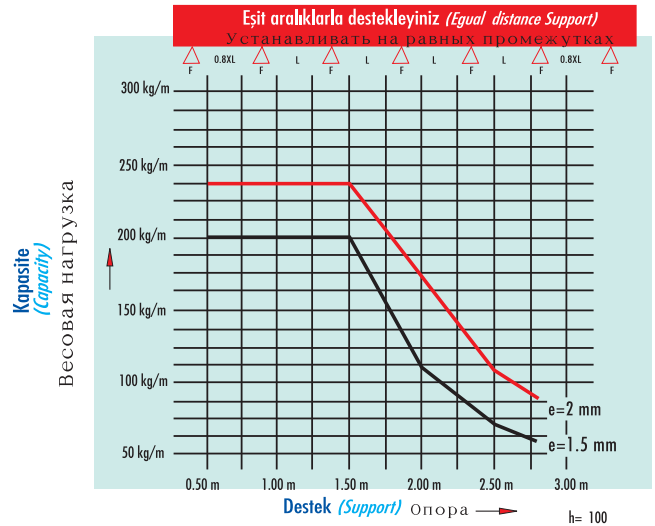

Malzeme : 304-316 (SS 304-316) Kalite Paslanmaz Sac (Cr-Ni).

Bu Ürünler İsteğe Bağlı Olarak EN-5052 Alüminyum Alaşım Sacdan İmal Edilebilir.

Material : 304-316 Quality (SS 304-316) Stainless Steel (Cr-Ni).

These Products Can Be Produced From Aluminium EN-5052 Steel According To The Requirements.

## AĞIR HİZMET DÖNÜŞ ELEMANLARI

## Heavy Duty Flat Bends

## Сверхмощные угловые элементы

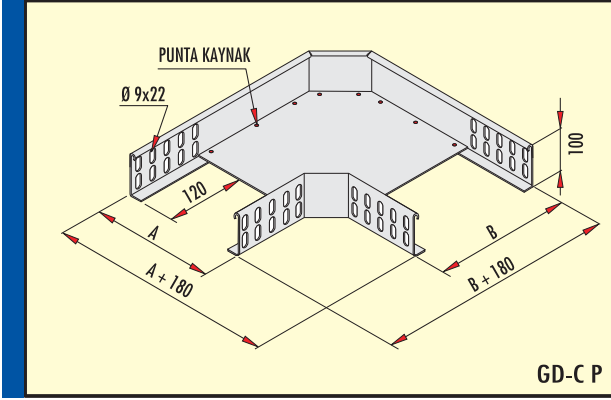

Ağır Hizmet 90° Dönüş Elemanı h=100 mm PASLANMAZ SAC (Cr-Ni)  
90° Heavy Duty Flat Bend h=100 mm Stainless Steel (Cr-Ni)  
Сверхмощные угловые элементы 90°

Sipariş kodu Order code Код заявки	Ağırlık (Kg/ad.) Weight (Kg/unit) Вес (кг/шт)	A mm	B mm	e mm	Price list прайс-лист шт/у.е.
GD - C10 P	1,650	104	104	1,5	39,60
GD - C20 P	2,400	205	205	1,5	57,60
GD - C30 P	4,300	305	305	2	103,20
GD - C40 P	5,850	405	405	2	140,50
GD - C50 P	7,650	506	506	2	183,60
GD - C60 P	9,750	606	606	2	234,00

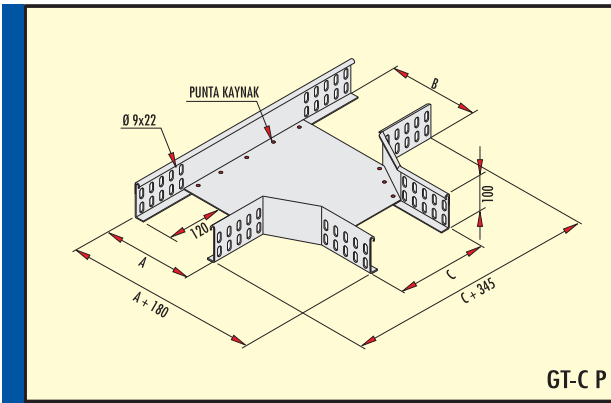

Ağır Hizmet T Bağlantı Elemanı h=100 mm PASLANMAZ SAC (Cr-Ni)  
Heavy Duty Tees "T" h=100 mm Stainless Steel (Cr-Ni)  
Сверхмощные «Т» образные соединительные элементы

Sipariş kodu Order code Код заявки	Ağırlık (Kg/ad.) Weight (Kg/unit) Вес (кг/шт)	A mm	B mm	C mm	e mm	Price list прайс-лист шт/у.е.
GT - C10 P	2,170	104	104	104	1,5	52,08
GT - C20 P	3,100	205	205	205	1,5	74,40
GT - C30 P	5,450	305	305	305	2	130,80
GT - C40 P	7,200	405	405	405	2	172,80
GT - C50 P	8,900	506	506	506	2	213,60
GT - C60 P	11,250	606	606	606	2	270,00

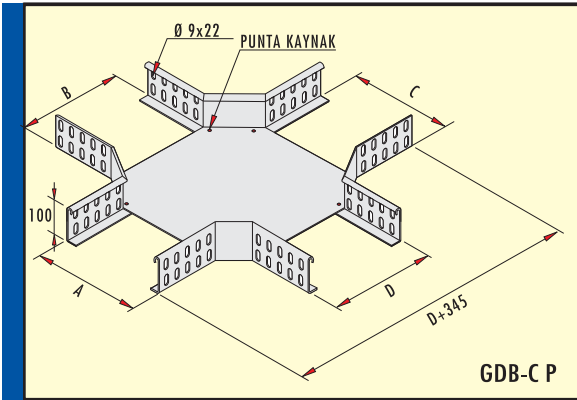

Ağır Hizmet Dörtlü Bağlantı Elemanı h=100 mm PASLANMAZ SAC (Cr-Ni)  
Heavy Duty Crossing h=100 mm Stainless Steel (Cr-Ni)  
Сверхмощные крестообразные соединительные элементы

Sipariş kodu Order code Код заявки	Ağırlık (Kg/ad.) Weight (Kg/unit) Вес (кг/шт)	A mm	B mm	C mm	D mm	e mm	Price list прайс-лист шт/у.е.
GDB - C10 P	2,000	104	104	104	104	1,5	48,00
GDB - C20 P	3,400	205	205	205	205	1,5	81,60
GDB - C30 P	5,650	305	305	305	305	2	135,60
GDB - C40 P	7,300	405	405	405	405	2	175,20
GDB - C50 P	8,800	506	506	506	506	2	211,20
GDB - C60 P	11,000	606	606	606	606	2	264,00

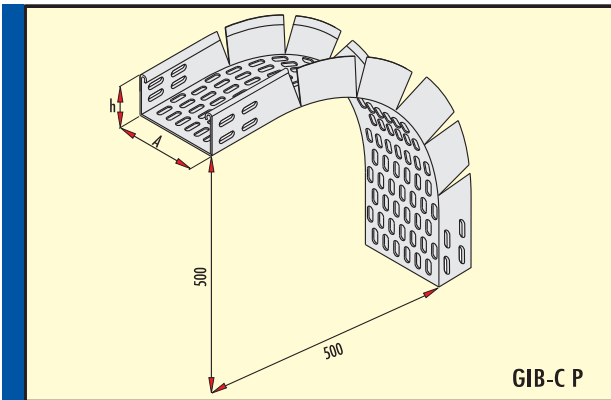

Ağır Hizmet İç-Dış Bükü Elemanı h=100 mm PASLANMAZ SAC (Cr-Ni)  
Heavy Duty Inside and Outside Vertical Bend h=100 mm Stainless Steel (Cr-Ni)  
Внутри и снаружи Вертикальных Изгибов

Sipariş kodu Order code Код заявки	Ağırlık (Kg/ad.) Weight (Kg/unit) Вес (кг/шт)	A mm	h mm	e mm	Price list прайс-лист шт/у.е.
GIB - C10 P	3,300	100	100	1,5	79,20
GIB - C20 P	4,200	200	100	1,5	100,00
GIB - C30 P	7,000	300	100	2	168,00
GIB - C40 P	7,800	400	100	2	187,20
GIB - C50 P	9,050	500	100	2	217,20
GIB - C60 P	10,750	600	100	2	258,00

Bu Ürünler İsteğe Bağlı 300, 450 ve 600 Radüslü Olarak İmal Edilebilir. *These products can be manufactured radius 300, 450 and radius 600 due to request.*

Эти продукты могут быть изготовленным радиусом 300, 450 и радиусом 600 из-за request.

Malzeme : 304-316 (SS 304-316) Kalite Paslanmaz Sac (Cr-Ni).

Material : 304-316 Quality (SS 304-316) Stainless Steel (Cr-Ni).

Bu Ürünler İsteğe Bağlı Olarak EN-5052 Alüminyum Alaşım Sacdan İmal Edilebilir.

These Products Can Be Produced From Aluminium EN-5052 Steel According To The Requirements.

DÖNÜŞ ELEMANLARI

Flat Bends

Угловые элементы

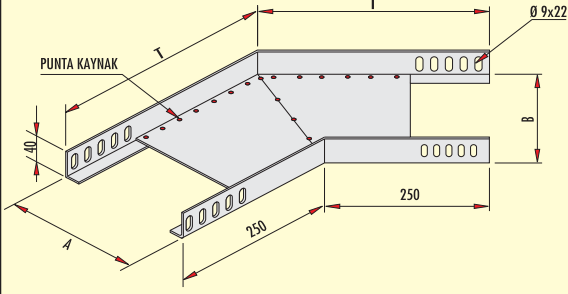

GD-45 P

135° Dönüş Elemanı h=40 mm PASLANMAZ SAC (Cr-Ni)

135° Flat Bend h=40 mm Stainless Steel (Cr-Ni)

Плоский Изгиб 135°

Sipariş kodu Order code Код заявки	Ağırlık (Kg/ad.) Weight (Kg/unit) Вес (кг/шт)	A mm	B mm	T mm	e mm	Price list прайс-лист шт/у.е.
GD-5 -45 P	0,400	54	54	271	1	9,60
GD-10 -45 P	0,750	104	104	291	1,5	18,00
GD-20 -45 P	1,600	205	205	333	1,5	38,40
GD-30 -45 P	3,000	305	305	374	2	72,00
GD-40 -45 P	3,250	405	405	416	2	78,00
GD-50 -45 P	4,950	506	506	457	2	118,80
GD-60 -45 P	5,650	606	606	499	2	135,60

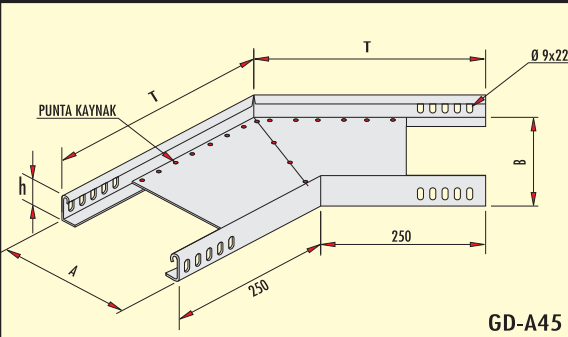

GD-A45 P  
GD-B45 P

135° Ağır Hizmet Dönüş Elemanı PASLANMAZ SAC (Cr-Ni)

135° Heavy Duty Flat Bend Stainless Steel (Cr-Ni)

Плоский Изгиб 135°

Sipariş kodu Order code Код заявки	Ağırlık (Kg/ad.) Weight (Kg/unit) Вес (кг/шт)	A-B mm	h mm	T mm	e mm	Price list прайс-лист шт/у.е.
GD-A5 -45 P	0,450	54	40	271	1	10,80
GD-A10 -45 P	0,900	104	40	291	1,5	21,60
GD-A20 -45 P	1,800	205	40	333	1,5	43,20
GD-A30 -45 P	3,050	305	40	374	2	73,20
GD-A40 -45 P	3,200	405	40	416	2	76,80
GD-A50 -45 P	5,300	506	40	457	2	127,20
GD-A60 -45 P	6,500	606	40	499	2	156,00
GD-B5 -45 P	1,050	54	60	271	1	25,20
GD-B10 -45 P	1,800	104	60	291	1,5	43,20
GD-B20 -45 P	2,100	205	60	333	1,5	50,40
GD-B30 -45 P	3,250	305	60	374	2	78,00
GD-B40 -45 P	4,000	405	60	416	2	96,00
GD-B50 -45 P	5,700	506	60	457	2	136,80
GD-B60 -45 P	6,950	606	60	499	2	166,80

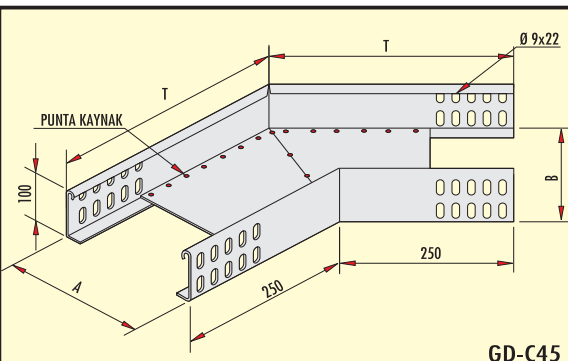

GD-C45 P

135° Ağır Hizmet Dönüş Elemanı h=100 mm PASLANMAZ SAC (Cr-Ni)

135° Heavy Duty Flat Bend h=100 mm Stainless Steel (Cr-Ni)

Плоский Изгиб 135°

Sipariş kodu Order code Код заявки	Ağırlık (Kg/ad.) Weight (Kg/unit) Вес (кг/шт)	A mm	B mm	T mm	e mm	Price list прайс-лист шт/у.е.
GD-C10 -45 P	1,350	104	104	291	1,5	32,40
GD-C20 -45 P	2,600	205	205	333	1,5	62,40
GD-C30 -45 P	4,300	305	305	374	2	103,20
GD-C40 -45 P	5,400	405	405	416	2	129,60
GD-C50 -45 P	6,500	506	506	457	2	156,00
GD-C60 -45 P	7,850	606	606	499	2	188,40

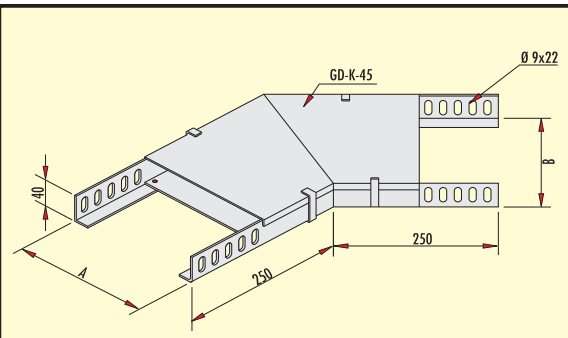

GD-K-45 P

135° Dönüş Kapağı PASLANMAZ SAC (Cr-Ni)

135° Flat Bend Cover Stainless Steel (Cr-Ni)

Плоский Изгиб Покрытие 135°

Sipariş kodu Order code Код заявки	Ağırlık (Kg/ad.) Weight (Kg/unit) Вес (кг/шт)	A mm	B mm	e mm	Price list прайс-лист шт/у.е.
GD-5K -45 P	0,200	54	54	1	4,80
GD-10K -45 P	0,300	104	104	1	7,20
GD-20K -45 P	0,650	205	205	1	15,60
GD-30K -45 P	1,000	305	305	1	24,00
GD-40K -45 P	2,300	405	405	1,5	55,20
GD-50K -45 P	3,150	506	506	1,5	75,60
GD-60K -45 P	4,300	606	606	1,5	103,20

Malzeme : 304-316 (SS 304-316) Kalite Paslanmaz Sac (Cr-Ni).

Bu Ürünler İsteğe Bağlı Olarak EN-5052 Alüminyum Alaşım Sacdan İmal Edilebilir.

Material : 304-316 Quality (SS 304-316) Stainless Steel (Cr-Ni).

These Products Can Be Produced From Aluminium EN-5052 Steel According To The Requirements.

## C PROFİL BASAMAKLI KABLO MERDİVENİ

## Cable Ladder With C-Profile Rung

Кабельная Лестница Со Ступеньками С-профиля

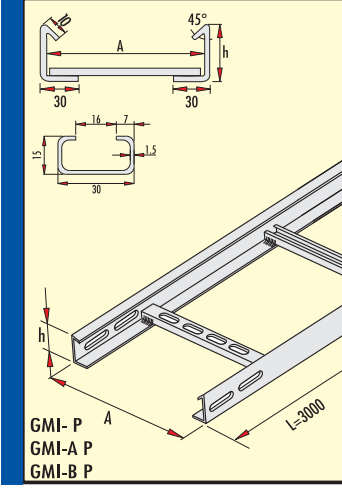

### C Profil Basamaklı Kablo Merdiveni PASLANMAZ SAC (Cr-Ni) Cable Ladder With C-Profile Rung Stainless Steel (Cr-Ni)

Кабельная Лестница Со Ступеньками С-профиля

Sipariş kodu Order code Код заявки	Ağırlık (Kg/mt.) Weight (Kg/mt) Вес (кг/м)	A mm	h mm	e mm	Price list прайс-лист м/у.е.
GMI - 10 P	2,300	100	50	1,5	50,00
GMI - 20 P	2,500	200	50	1,5	55,00
GMI - 30 P	2,700	300	50	1,5	59,00
GMI - 40 P	3,600	400	50	2	79,00
GMI - 50 P	3,750	500	50	2	83,00
GMI - 60 P	3,900	600	50	2	86,00
GMI - A10 P	2,600	100	60	1,5	57,00
GMI - A20 P	2,800	200	60	1,5	62,00
GMI - A30 P	2,950	300	60	1,5	65,00
GMI - A40 P	3,900	400	60	2	86,00
GMI - A50 P	4,100	500	60	2	90,00
GMI - A60 P	4,300	600	60	2	95,00
GMI - B10 P	4,000	100	70	2	88,00
GMI - B20 P	4,100	200	70	2	90,00
GMI - B30 P	4,200	300	70	2	93,00
GMI - B40 P	4,300	400	70	2	95,00
GMI - B50 P	4,450	500	70	2	98,00
GMI - B60 P	4,600	600	70	2	101,00

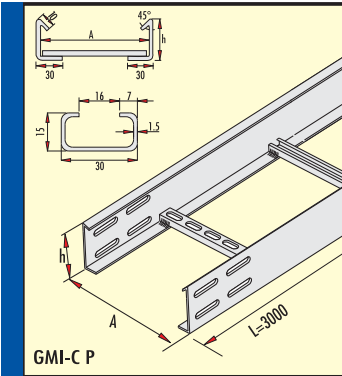

### C Profil Basamaklı Kablo Merdiveni PASLANMAZ SAC (Cr-Ni) Cable Ladder With C-Profile Rung Stainless Steel (Cr-Ni)

Кабельная Лестница Со Ступеньками С-профиля

Sipariş kodu Order code Код заявки	Ağırlık (Kg/mt.) Weight (Kg/mt) Вес (кг/м)	A mm	h mm	e mm	Price list прайс-лист м/у.е.
GMI - C20 P	4,900	200	100	2	108,00
GMI - C30 P	5,100	300	100	2	112,00
GMI - C40 P	5,400	400	100	2	119,00
GMI - C50 P	5,700	500	100	2	125,00
GMI - C60 P	5,950	600	100	2	131,00



## EK PARÇASI

## Jointing Piece

Соединительные элементы

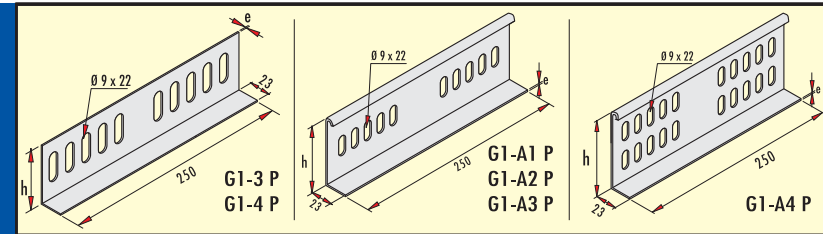

### Ek Parçası PASLANMAZ SAC (Cr-Ni) Jointing Piece Stainless Steel (Cr-Ni)

Соединительные элементы

Sipariş kodu Order code Код заявки	Ağırlık (Kg/ad.) Weight (Kg/unit) Вес (кг/шт)	h mm	e mm	Price list прайс-лист шт/у.е.
G1 - 3P	0,240	50	2	5,80
G1 - 4P	0,270	60	2	6,50
G1 - 5P	0,420	100	2	10,00
G1 - A1 P	0,300	54	2	7,20
G1 - A2 P	0,330	64	2	8,00
G1 - A3 P	0,350	74	2	8,40
G1 - A4 P	0,560	104	2	13,00

Malzeme : 304-316 (SS 304-316) Kalite Paslanmaz Sac (Cr-Ni).

Bu Ürünler İsteğe Bağlı Olarak EN-5052 Alüminyum Alaşım Sacdan İmal Edilebilir.

Material : 304-316 Quality (SS 304-316) Stainless Steel (Cr-Ni).

These Products Can Be Produced From Aluminium EN-5052 Steel According To The Requirements.

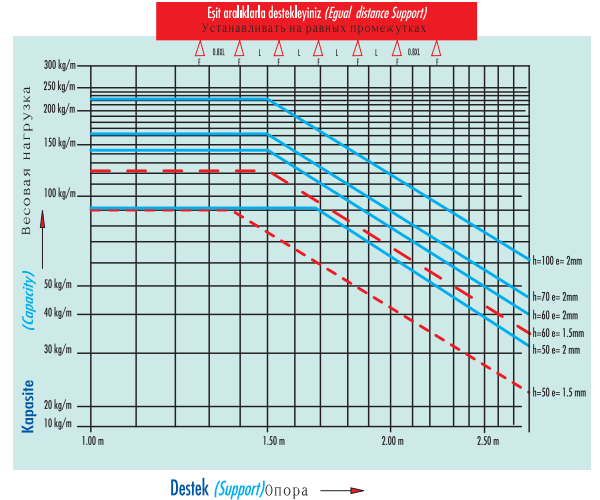



DÖNÜŞ ELEMANLARI

Flat Bends

Угловые элементы

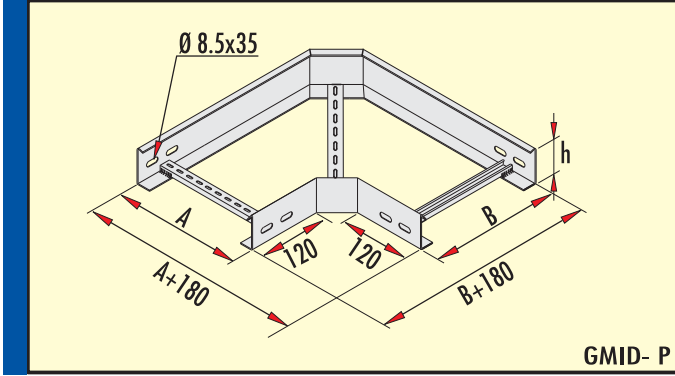

90° Dönüş Elemanı PASLANMAZ SAC (Cr-Ni) 90° Flat Bend Stainless Steel (Cr-Ni)  
угловые элементы 90°

Sipariş kodu Order code Код заявки	Ağırlık (Kg/ad.) Weight (Kg/unit) Вес (кг/шт)	A mm	B mm	h mm	e mm	Price list прайс-лист шт./у.е.
GMID - 10 P	1,300	100	100	50	2	32,50
GMID - 20 P	1,900	200	200	50	2	47,50
GMID - 30 P	2,500	300	300	50	2	62,50
GMID - 40 P	3,100	400	400	50	2	77,50
GMID - 50 P	3,700	500	500	50	2	92,50
GMID - 60 P	4,300	600	600	50	2	107,50
GMID - A10 P	1,600	100	100	60	2	40,00
GMID - A20 P	2,100	200	200	60	2	52,50
GMID - A30 P	2,700	300	300	60	2	67,50
GMID - A40 P	3,300	400	400	60	2	82,50
GMID - A50 P	3,900	500	500	60	2	97,50
GMID - A60 P	4,500	600	600	60	2	112,50
GMID - B10 P	1,700	100	100	70	2	42,50
GMID - B20 P	2,300	200	200	70	2	57,50
GMID - B30 P	3,100	300	300	70	2	77,50
GMID - B40 P	3,500	400	400	70	2	87,50
GMID - B50 P	4,100	500	500	70	2	102,50
GMID - B60 P	4,600	600	600	70	2	115,00

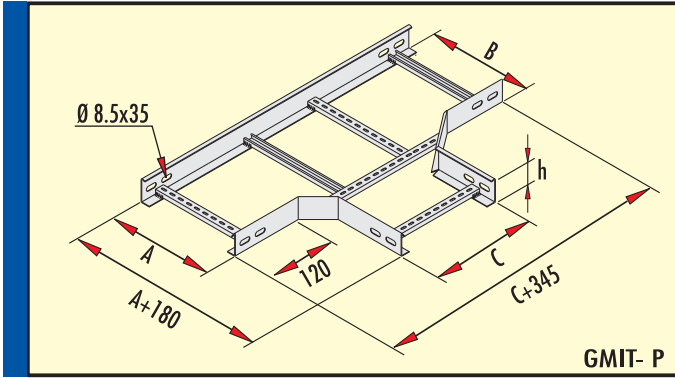

"T" Bağlantı Elemanı PASLANMAZ SAC (Cr-Ni)  
Tee "T" Elements Stainless Steel (Cr-Ni)  
«Т» образные соединительные элементы

Sipariş kodu Order code Код заявки	Ağırlık (Kg/ad.) Weight (Kg/unit) Вес (кг/шт)	A-B-C mm	h mm	e mm	Price list прайс-лист шт./у.е.
GMIT - 10 P	2,100	100	50	2	52,50
GMIT - 20 P	2,500	200	50	2	62,50
GMIT - 30 P	2,900	300	50	2	72,50
GMIT - 40 P	3,400	400	50	2	85,00
GMIT - 50 P	3,850	500	50	2	96,25
GMIT - 60 P	4,250	600	50	2	106,25
GMIT - A10 P	2,150	100	60	2	53,75
GMIT - A20 P	2,650	200	60	2	66,25
GMIT - A30 P	3,100	300	60	2	77,50
GMIT - A40 P	3,550	400	60	2	88,75
GMIT - A50 P	4,000	500	60	2	100,00
GMIT - A60 P	4,450	600	60	2	111,25
GMIT - B10 P	2,400	100	70	2	60,00
GMIT - B20 P	2,900	200	70	2	72,50
GMIT - B30 P	3,100	300	70	2	77,50
GMIT - B40 P	3,350	400	70	2	83,75
GMIT - B50 P	3,800	500	70	2	95,00
GMIT - B60 P	4,750	600	70	2	118,75

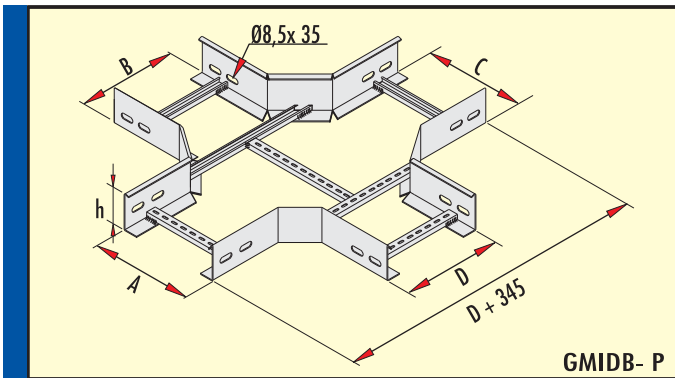

Dörtlü Bağlantı Elemanı PASLANMAZ SAC (Cr-Ni)  
Crossing Element Stainless Steel (Cr-Ni)

Пе есечение Элементов

Sipariş kodu Order code Код заявки	Ağırlık (Kg/ad.) Weight (Kg/unit) Вес (кг/шт)	A-B-C-D mm	h mm	e mm	Price list прайс-лист шт./у.е.
GMIDB - 10 P	2,400	100	50	2	60,00
GMIDB - 20 P	2,900	200	50	2	72,50
GMIDB - 30 P	3,450	300	50	2	86,25
GMIDB - 40 P	4,250	400	50	2	106,25
GMIDB - 50 P	4,900	500	50	2	122,50
GMIDB - 60 P	5,950	600	50	2	148,75
GMIDB - A10 P	2,800	100	60	2	70,00
GMIDB - A20 P	3,200	200	60	2	80,00
GMIDB - A30 P	3,750	300	60	2	93,75
GMIDB - A40 P	4,500	400	60	2	112,50
GMIDB - A50 P	5,350	500	60	2	133,75
GMIDB - A60 P	6,100	600	60	2	152,50
GMIDB - B10 P	3,000	100	70	2	75,00
GMIDB - B20 P	3,450	200	70	2	86,25
GMIDB - B30 P	4,000	300	70	2	100,00
GMIDB - B40 P	4,800	400	70	2	120,00
GMIDB - B50 P	5,750	500	70	2	143,75
GMIDB - B60 P	6,500	600	70	2	162,50

Bu ürünler isteğe bağlı 300, 450 ve 600 Radüslü Olarak İmal Edilebilir. These products can be manufactured radius 300, 450 and radius 600 due to request.

Эти продукты могут быть изготовленными радиусом 300, 450 и радиусом 600 из-за request.

Malzeme : 304-316 (SS 304-316) Kalite Paslanmaz Sac (Cr-Ni).

Material : 304-316 Quality (SS 304-316) Stainless Steel (Cr-Ni).

Bu ürünler isteğe bağlı Olarak EN-5052 Alüminyum Alaşım Sacdan İmal Edilebilir.

These Products Can Be Produced From Aluminium EN-5052 Steel According To The Requirements.



DÖNÜŞ ELEMANLARI

Flat Bends

УГЛОВЫЕ ЭЛЕМЕНТЫ

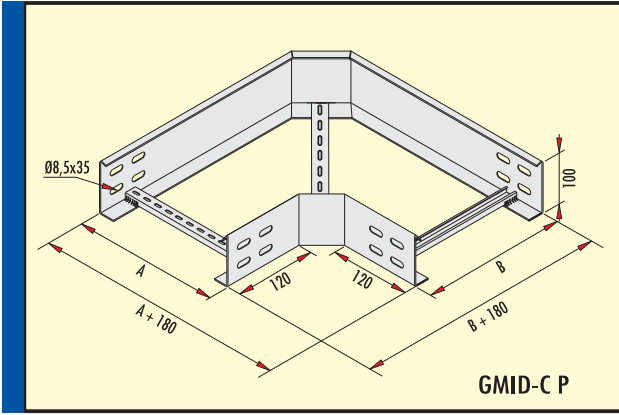

90° Dönüş Elemanı h=100 mm PASLANMAZ SAC (Cr-Ni)

90° Flat Bend h=100 mm Stainless Steel (Cr-Ni)

угловые элементы 90°

Sipariş kodu Order code Код заявки	Ağırlık (Kg/ad.) Weight (Kg/unit) Вес (кг/шт)	A mm	B mm	e mm	Price list прайс-лист шт./у.е.
GMID - C20 P	3,100	200	200	2	77,50
GMID - C30 P	3,550	300	300	2	88,75
GMID - C40 P	4,000	400	400	2	100,00
GMID - C50 P	4,400	500	500	2	110,00
GMID - C60 P	4,850	600	600	2	121,25

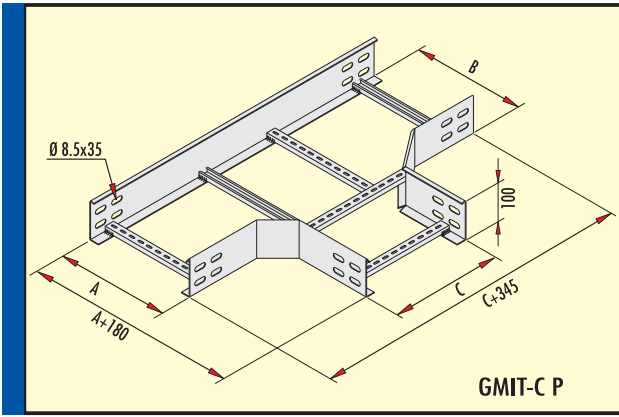

"T" Bağlantı Elemanı h=100 mm PASLANMAZ SAC (Cr-Ni)

Tee "T" Element h=100 mm Stainless Steel (Cr-Ni)

«Т» образные соединительные элементы

Sipariş kodu Order code Код заявки	Ağırlık (Kg/ad.) Weight (Kg/unit) Вес (кг/шт)	A-B-C mm	e mm	Price list прайс-лист шт./у.е.
GMIT - C20 P	3,450	200	2	86,25
GMIT - C30 P	4,000	300	2	100,00
GMIT - C40 P	4,450	400	2	111,25
GMIT - C50 P	5,000	500	2	125,00
GMIT - C60 P	5,450	600	2	136,25

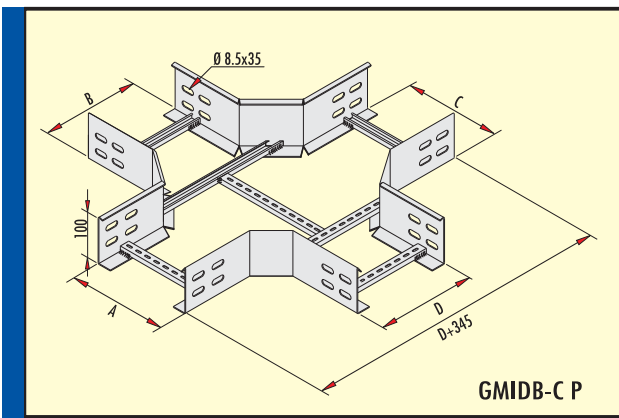

Dörtlü Bağlantı Elemanı h=100 mm PASLANMAZ SAC (Cr-Ni)

Crossing Element h=100 mm Stainless Steel (Cr-Ni)

Пересечение Покрывтий Элемента

Sipariş kodu Order code Код заявки	Ağırlık (Kg/ad.) Weight (Kg/unit) Вес (кг/шт)	A-B-C mm	e mm	Price list прайс-лист шт./у.е.
GMIDB - C20 P	4,400	200	2	110,00
GMIDB - C30 P	5,300	300	2	132,50
GMIDB - C40 P	6,000	400	2	150,00
GMIDB - C50 P	6,700	500	2	167,50
GMIDB - C60 P	7,500	600	2	187,50

Bu Ürünler İsteğe Bağlı 300, 450 ve 600 Radüslü Olarak İmal Edilebilir. These products can be manufactured radius 300, 450 and radius 600 due to request.

Эти продукты могут быть изготовленным радиусом 300, 450 и радиусом 600 из-за request.

Malzeme : 304-316 (SS 304-316) Kalite Paslanmaz Sac (Cr-Ni).

Bu Ürünler İsteğe Bağlı Olarak EN-5052 Alüminyum Alaşım Sacdan İmal Edilebilir.

Material : 304-316 Quality (SS 304-316) Stainless Steel (Cr-Ni).

These Products Can Be Produced From Aluminium EN-5052 Steel According To The Requirements.

## DÖNÜŞ KAPAKLARI

### Flat Bend Covers

### Плоские Покрытия Изгиба

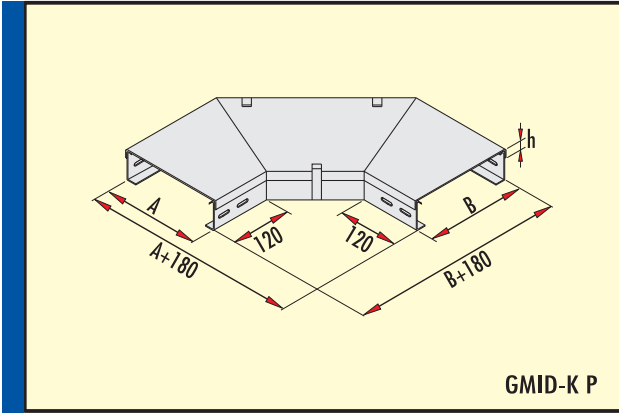

#### 90° Dönüş Eleman Kapağı

#### 90° Flat Bend Cover

90° Плоских Покрытий Изгиба

Sipariş kodu Order code Код заявки	Ağırlık (Kg/ad.) Weight (Kg/unit) Вес (кг/шт)	A mm	B mm	e mm	h mm	Price list прайс-лист шт/у.е.
GMID - 10K P	0,500	100	100	1	9	12,50
GMID - 20K P	0,800	200	200	1	9	20,00
GMID - 30K P	1,400	300	300	1	9	35,00
GMID - 40K P	3,500	400	400	1,5	9	87,50
GMID - 50K P	4,650	500	500	1,5	9	116,25
GMID - 60K P	6,450	600	600	1,5	9	161,25

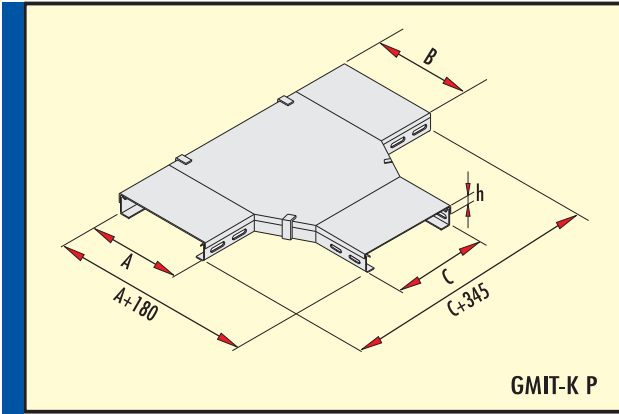

#### "T" Bağlantı Eleman Kapağı

#### Tee "T" Element Cover

Мишень "Т" Покрытия Элемента

Sipariş kodu Order code Код заявки	Ağırlık (Kg/ad.) Weight (Kg/unit) Вес (кг/шт)	A-B-C mm	e mm	h mm	Price list прайс-лист шт/у.е.
GMIT - 10K P	1,000	100	1	9	25,00
GMIT - 20K P	1,300	200	1	9	32,50
GMIT - 30K P	2,150	300	1	9	53,75
GMIT - 40K P	4,750	400	1,5	9	118,75
GMIT - 50K P	6,500	500	1,5	9	162,50
GMIT - 60K P	8,400	600	1,5	9	210,00

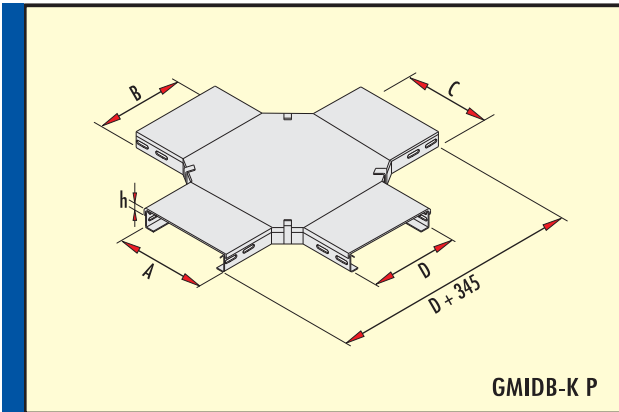

#### Dörtlü Bağlantı Eleman Kapağı

#### Crossing Element Cover

Пересечение Покрытий Элемента

Sipariş kodu Order code Код заявки	Ağırlık (Kg/ad.) Weight (Kg/unit) Вес (кг/шт)	A-B-C-D mm	e mm	h mm	Price list прайс-лист шт/у.е.
GMIDB - 10K P	1,000	100	1	9	25,00
GMIDB - 20K P	1,700	200	1	9	42,50
GMIDB - 30K P	2,700	300	1	9	67,50
GMIDB - 40K P	6,050	400	1,5	9	151,25
GMIDB - 50K P	8,200	500	1,5	9	205,00
GMIDB - 60K P	10,600	600	1,5	9	265,00

Bu ürünler isteğe bağlı 300, 450 ve 600 Radüslü Olarak İmal Edilebilir. *These products can be manufactured radius 300, 450 and radius 600 due to request.*  
Эти продукты могут быть изготовленным радиусом 300, 450 и радиусом 600 из-за request.

Malzeme : 304-316 (SS 304-316) Kalite Paslanmaz Sac (Cr-Ni).  
Bu ürünler isteğe bağlı olarak EN-5052 Alüminyum Alaşım Sacdan İmal Edilebilir.

Material : 304-316 Quality (SS 304-316) Stainless Steel (Cr-Ni).  
These Products Can Be Produced From Aluminium EN-5052 Steel According To The Requirements.

135° DÖNÜŞ ELEMANLARI

135° Flat Bend Elements

135° Квартир Сгибают Элементы

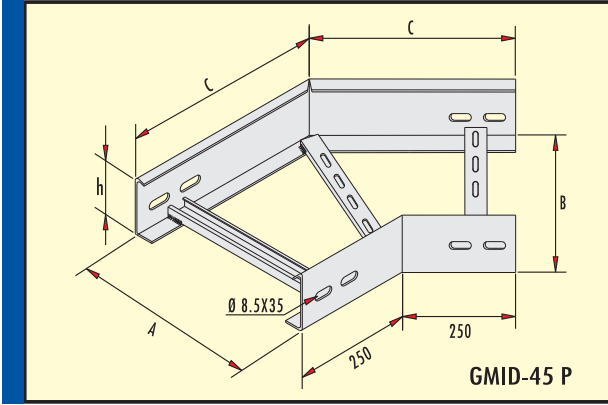

135° Dönüş Elemanı

135° Flat Bend Element

135° Ква ти Сгибают Элемент

Sipariş kodu Order code Код заявки	Ağırlık (Kg/ad.) Weight (Kg/unit) Вес (кг/шт)	A-B mm	C mm	e mm	h mm	Price list прайс-лист шт/у.е.
GMID - 10-45 P	1,600	100	333	2	50	40,00
GMID - 20 -45 P	1,950	200	333	2	50	48,75
GMID - 30 -45 P	2,300	300	374	2	50	57,50
GMID - 40 -45 P	2,600	400	416	2	50	65,00
GMID - 50 -45 P	2,950	500	457	2	50	73,75
GMID - 60 -45 P	3,250	600	499	2	50	81,25
GMID - A10 -45 P	1,850	100	333	2	60	46,25
GMID - A20 -45 P	2,050	200	333	2	60	51,25
GMID - A30 -45 P	2,400	300	374	2	60	60,00
GMID - A40 -45 P	2,750	400	416	2	60	68,75
GMID - A50 -45 P	3,100	500	457	2	60	77,50
GMID - A60 -45 P	3,450	600	499	2	60	86,25
GMID - B10 -45 P	2,100	100	333	2	70	52,50
GMID - B20 -45 P	2,400	200	333	2	70	60,00
GMID - B30 -45 P	2,750	300	374	2	70	68,75
GMID - B40 -45 P	3,050	400	416	2	70	76,25
GMID - B50 -45 P	3,400	500	457	2	70	85,00
GMID - B60 -45 P	3,750	600	499	2	70	93,75

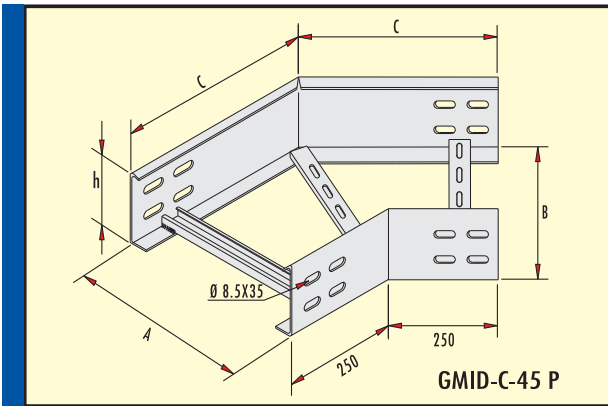

135° Dönüş Elemanı (h=100 mm)

135° Flat Bend Element (h=100 mm)

135° Квартир Сгибают Элемент

Sipariş kodu Order code Код заявки	Ağırlık (Kg/ad.) Weight (Kg/unit) Вес (кг/шт)	A-B mm	C mm	e mm	h mm	Price list прайс-лист шт/у.е.
GMID - C20 -45 P	2,650	200	333	2	100	66,25
GMID - C30 -45 P	3,050	300	374	2	100	76,25
GMID - C40 -45 P	3,450	400	416	2	100	86,25
GMID - C50 -45 P	3,850	500	457	2	100	96,25
GMID - C60 -45 P	4,250	600	499	2	100	106,25

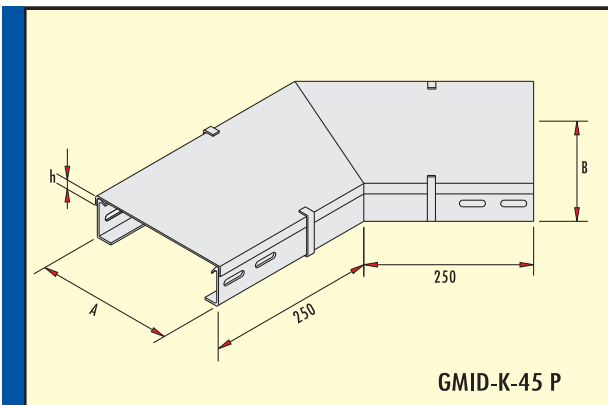

135° Dönüş Eleman Kapağı

135° Flat Bend Element Cover

135° Квартир Сгибают Покрытие Элемента

Sipariş kodu Order code Код заявки	Ağırlık (Kg/ad.) Weight (Kg/unit) Вес (кг/шт)	A mm	B mm	e mm	h mm	Price list прайс-лист шт/у.е.
GMID - 10K -45 P	0,700	100	100	1,5	9	17,50
GMID - 20K -45 P	1,050	200	200	1,5	9	26,25
GMID - 30K -45 P	1,600	300	300	1,5	9	40,00
GMID - 40K -45 P	3,200	400	400	1,5	9	80,00
GMID - 50K -45 P	4,400	500	500	2	9	110,00
GMID - 60K -45 P	5,500	600	600	2	9	137,50

Malzeme : 304-316 (SS 304-316) Kalite Paslanmaz Sac (Cr-Ni).

Bu Ürünler İsteğe Bağlı Olarak EN-5052 Alüminyum Alaşım Sacdan İmal Edilebilir.

Material : 304-316 Quality (SS 304-316) Stainless Steel (Cr-Ni).

These Products Can Be Produced From Aluminium EN-5052 Steel According To The Requirements.



## İÇ-DIŞ BÜKEY BAĞLANTI ELEMANLARI Inside and Outside Vertical Bends Elements

Внутри и снаружи Вертикальных Элементов Изгибов

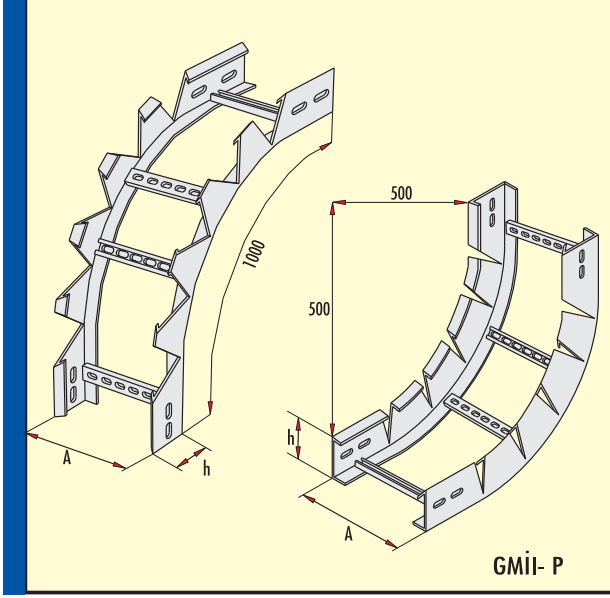

### İç-Dış Bükey Bağlantı Elemanı Inside and Outside Vertical Bend Element

Внутри и снаружи Вертикальных Элементов Изгибов

Sipariş kodu Order code Код заявки	Ağırlık (Kg/ad.) Weight (Kg/unit) Вес (кг / шт)	A mm	e mm	h mm	Price list прайс-лист шт./у.е.
GMİ - 10 P	2,700	100	2	50	67,50
GMİ - 20 P	3,000	200	2	50	75,00
GMİ - 30 P	3,290	300	2	50	82,25
GMİ - 40 P	3,500	400	2	50	87,50
GMİ - 50 P	3,730	500	2	50	93,25
GMİ - 60 P	3,900	600	2	50	97,50
GMİ - A10 P	3,150	100	2	60	78,75
GMİ - A20 P	3,350	200	2	60	83,75
GMİ - A30 P	3,570	300	2	60	89,25
GMİ - A40 P	3,800	400	2	60	95,00
GMİ - A50 P	4,000	500	2	60	100,00
GMİ - A60 P	4,200	600	2	60	105,00
GMİ - B10 P	3,400	100	2	70	85,00
GMİ - B20 P	3,600	200	2	70	90,00
GMİ - B30 P	3,800	300	2	70	95,00
GMİ - B40 P	4,000	400	2	70	100,00
GMİ - B50 P	4,250	500	2	70	106,25
GMİ - B60 P	4,430	600	2	70	110,75

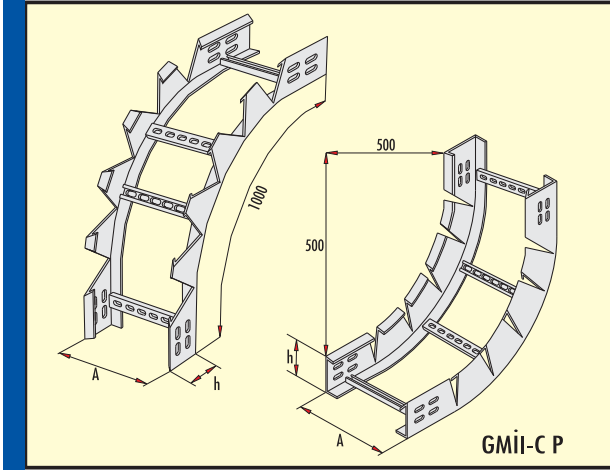

### İç-Dış Bükey Bağlantı Elemanı Inside and Outside Vertical Bend Element

Внутри и снаружи Вертикальных Элементов Изгибов

Sipariş kodu Order code Код заявки	Ağırlık (Kg/ad.) Weight (Kg/unit) Вес (кг / шт)	A mm	e mm	h mm	Price list прайс-лист шт./у.е.
GMİ - C20 P	5,600	200	2	100	140,00
GMİ - C30 P	6,000	300	2	100	150,00
GMİ - C40 P	6,420	400	2	100	160,50
GMİ - C50 P	6,800	500	2	100	170,00
GMİ - C60 P	7,000	600	2	100	175,00

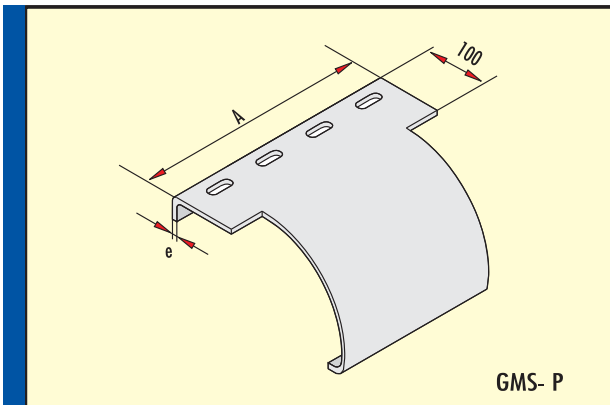

### Kablo Merdiveni Çıkış Alma Elemanı Cable Externalizing Unit

наружный элемент кабельных лестниц

Sipariş kodu Order code Код заявки	Ağırlık (Kg/ad.) Weight (Kg/unit) Вес (кг / шт)	A mm	e mm	Price list прайс-лист шт./у.е.
GMS - 10 P	0,650	95	1,5	16,25
GMS - 20 P	0,850	195	1,5	21,25
GMS - 30 P	1,400	295	1,5	35,00
GMS - 40 P	2,650	395	2	66,25
GMS - 50 P	3,400	495	2	85,00
GMS - 60 P	4,150	595	2	103,75

Malzeme : 304-316 (SS 304-316) Kalite Paslanmaz Sac (Cr-Ni).  
Bu Ürünler İsteğe Bağlı Olarak EN-5052 Alüminyum Alaşım Sacdan İmal Edilebilir.

Material : 304-316 Quality (SS 304-316) Stainless Steel (Cr-Ni).  
These Products Can Be Produced From Aluminium EN-5052 Steel According To The Requirements.



## KABLO KANAL KAPAKLARI

## Cover For Cable Tray

## Крышки для кабельных лотков

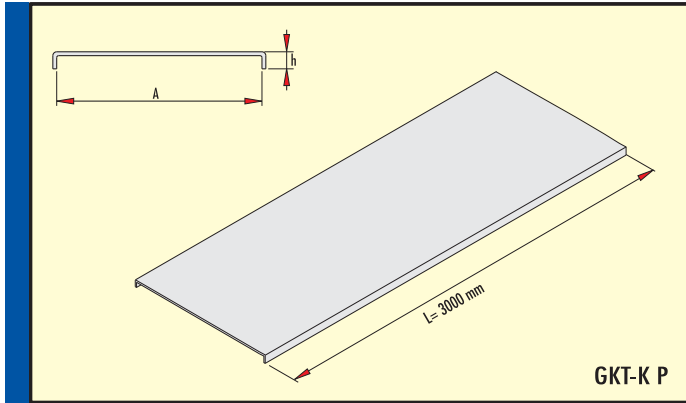

### Kablo Kanal Kapağı PASLANMAZ SAC (Cr-Ni) Cover For Cable Tray Stainless Steel (Cr-Ni)

Крышки для кабельных лотков

Sipariş kodu Order code Код заявки	Ağırlık (Kg/mt.) Weight (Kg/mt) Вес (кг/м)	A mm	h mm	e mm	Price list прайс-лист м/у.е.
GKT - 5K P	0,550	53	9	1	11,00
GKT - 10K P	1,000	103	9	1	20,00
GKT - 20K P	1,700	203	9	1	34,00
GKT - 30K P	2,550	305	9	1	51,00
GKT - 40K P	4,940	405	9	1,5	98,80
GKT - 50K P	6,150	505	9	1,5	123,00
GKT - 60KP	7,300	605	9	1,5	146,00

## SEPERATÖR

## Separator

## Сепаратор

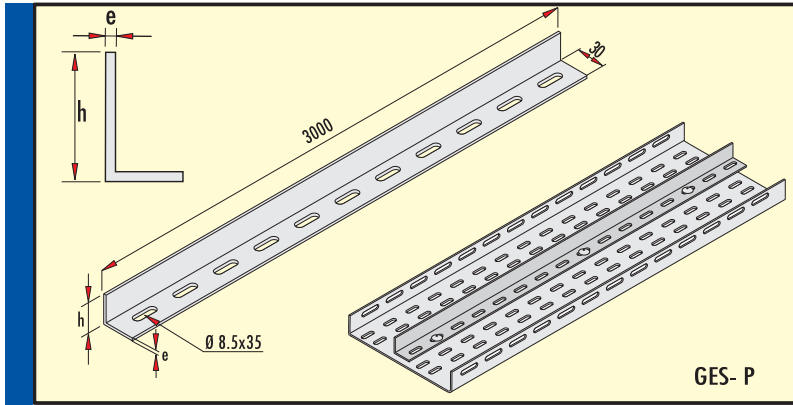

### Seperatör PASLANMAZ SAC (Cr-Ni) Separator Stainless Steel (Cr-Ni)

Сепаратор

Sipariş kodu Order code Код заявки	Ağırlık (Kg/mt.) Weight (Kg/mt) Вес (кг/м)	h mm	e mm	Price list прайс-лист м/у.е.
GES - 40 P	0,530	38	1	10,60
GES - 50 P	0,840	48	1,5	17,00
GES - 60 P	0,950	58	1,5	19,00
GES - 70 P	1,120	68	1,5	22,50
GES - 100 P	2,000	98	2	40,00

## KAPAK KELEPÇELERİ

## Cover Clamps

## Фиксаторы крышки

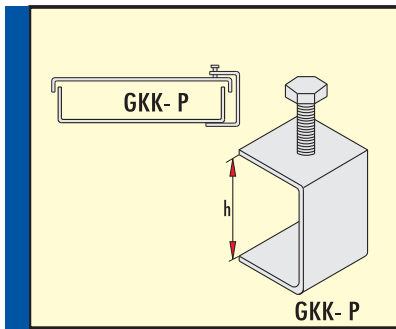

### Kapak Kelepçeleri Cover Clamps Фиксаторы крышки

Sipariş kodu Order code Код заявки	Ağırlık (Kg/ad.) Weight (Kg/unit) Вес (кг/шт)	h mm	e mm	Price list прайс-лист шт/у.е.
GKK - 45 P	0,040	45	2	1,12
GKK - 55 P	0,050	55	2	1,25
GKK - 65 P	0,060	65	2	1,50
GKK - 75 P	0,070	75	2	1,75
GKK - 105 P	0,080	105	2	2,00

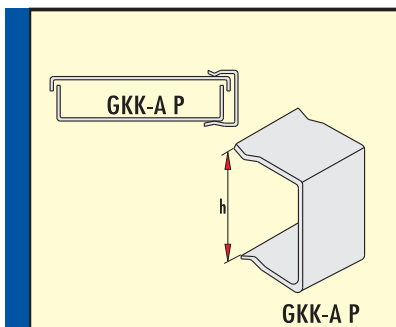
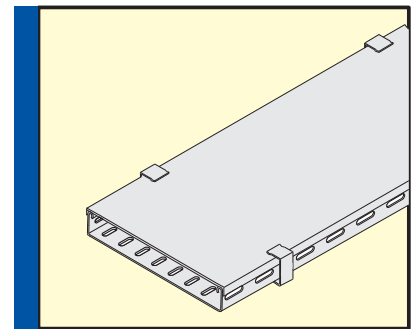

### Kapak Kelepçeleri Cover Clamps Фиксаторы крышки

Sipariş kodu Order code Код заявки	Ağırlık (Kg/ad.) Weight (Kg/unit) Вес (кг/шт)	h mm	e mm	Price list прайс-лист шт/у.е.
GKK - A45 P	0,040	45	2	1,12
GKK - A55 P	0,050	55	2	1,25
GKK - A65 P	0,050	65	2	1,50
GKK - A75 P	0,060	75	2	1,75
GKK - A105 P	0,070	105	2	2,00

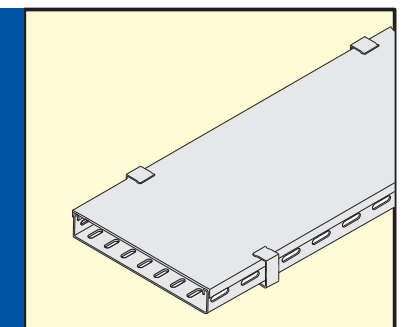

Malzeme : 304-316 (SS 304-316) Kalite Paslanmaz Sac (Cr-Ni).  
Bu Ürünler İsteğe Bağlı Olarak EN-5052 Alüminyum Alaşım Sacdan İmal Edilebilir.

Material : 304-316 Quality (SS 304-316) Stainless Steel (Cr-Ni).  
These Products Can Be Produced From Aluminium EN-5052 Steel According To The Requirements.



ALÜMİNYUM KABLO TAŞIYICILARI  
*Aluminium Cable Trays*  
Алюминий Телеграфируют По



ALÜMİNYUM PROFİL KABLO TAŞIYICILARI Aluminium Profile Cable Trays

Алюминиевые Подносы Кабеля Профиля

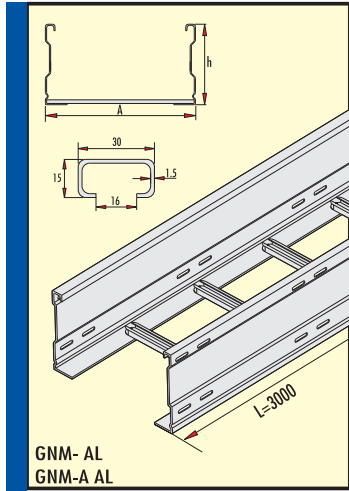

Alüminyum Profil Kablo Taşıyıcıları  
Aluminium Profile Cable Trays

Алюминиевые Подносы Кабеля Профиля

Sipariş kodu Order code Код заявки	Ağırlık (Kg/mt.) Weight (Kg/mt) Вес (кг/м)	A mm	h mm	e mm	Price list прайс-лист м/у.е.
GNM - 20 AL	1,470	200	70	2	25,00
GNM - 30 AL	1,560	300	70	2	27,00
GNM - 40 AL	1,640	400	70	2	28,00
GNM - 50 AL	1,730	500	70	2	30,00
GNM - 60 AL	1,820	600	70	2	31,00
GNM - A20 AL	1,790	200	100	2	30,50
GNM - A30 AL	1,880	300	100	2	32,00
GNM - A40 AL	1,970	400	100	2	34,00
GNM - A50 AL	2,060	500	100	2	35,00
GNM - A60 AL	2,150	600	100	2	37,00

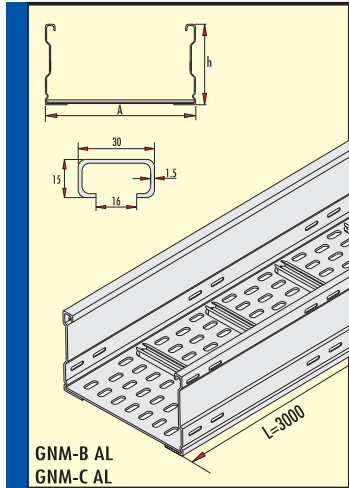

Alüminyum Profil Kablo Taşıyıcıları  
Aluminium Profile Cable Trays

Алюминиевые Подносы Кабеля Профиля

Sipariş kodu Order code Код заявки	Ağırlık (Kg/mt.) Weight (Kg/mt) Вес (кг/м)	A mm	h mm	e mm	Price list прайс-лист м/у.е.
GNM - B20 AL	2,550	200	70	2	43,00
GNM - B30 AL	2,640	300	70	2	45,00
GNM - B40 AL	2,720	400	70	2	46,00
GNM - B50 AL	2,810	500	70	2	48,00
GNM - B60 AL	2,900	600	70	2	49,00
GNM - C20 AL	2,870	200	100	2	48,80
GNM - C30 AL	2,960	300	100	2	50,00
GNM - C40 AL	3,050	400	100	2	52,00
GNM - C50 AL	3,140	500	100	2	53,50
GNM - C60 AL	3,270	600	100	2	56,00



EK PARÇASI

Jointing Piece

Соединительные элементы

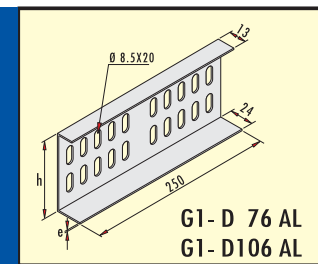

Ek Parçası Jointing Piece

Соединительные элементы

Sipariş kodu Order code Код заявки	Ağırlık (Kg/ad.) Weight (Kg/unit)	e mm	h mm	Price list прайс-лист шт/у.е.
G1 - D 76 AL	0,150	2	76	3,00
G1 - D 106 AL	0,200	2	106	6,00

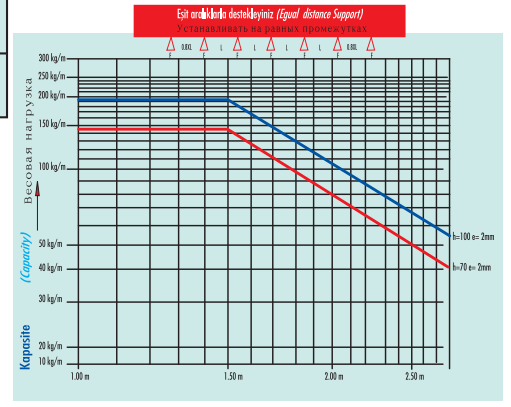

Malzeme : EN-6063 Alüminyum Alaşım Material : EN-6063 Aluminium Alloy.

Bu tip kablo taşıyıcılarında kullanılan kapak, ek elemanı, taban sacı vb. aksesuarlar EN-5052 alaşım alüminyumdan imal edilir.

Katalogumuzda belirtilen tüm sıcak daldırma galvaniz kablo taşıyıcıları ve aksesuarları istek üzerine EN-5052 alaşım alüminyum sacdan imal edilebilir.

Covers, jointing pieces, bottom plate and other accessories for EN-6063 aluminium alloy cable trays are produced from EN-5052 aluminium alloy plate. All hot dip galvanized materials mentioned in our catalog can be produced from EN-5052 aluminium alloy according to the requirements.

Покрyтия, соединяя части, подпочный щиток и other принадлежности для EN-6063 алюминиевых подносов кабеля сплава произведены от 5052 plate сплава алюминия. Гальванизированные материалы всего горячего падения, упомянутые в нашем каталоге могут быть произведены от EN-5052 алюминиевого сплава согласно требованиям.



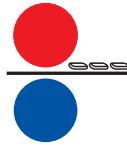

KABLO KANAL KAPAKLARI

Cover For Cable Tray

Крышки для кабельных лотков

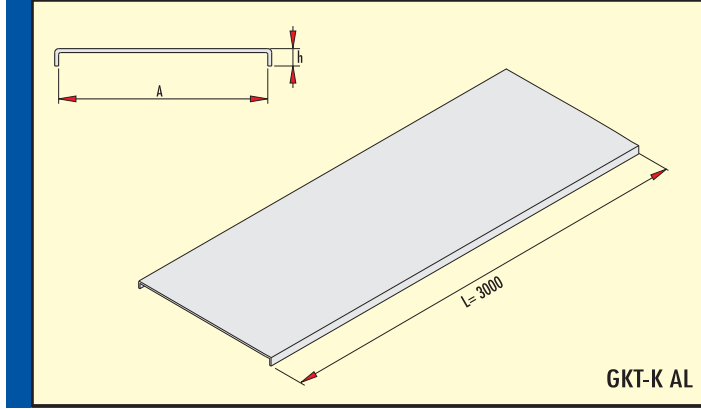

Kablo Kanal Kapağı (5052 ALÜMİNYUM ALAŞIM)  
Cover For Cable Tray (5052 Aluminium Alloy)  
Крышки для кабельных лотков

Sipariş kodu Order code Код заявки	Ağırlık (Kg/mt.) Weight (Kg/mt) Вес (кг/м)	A mm	h mm	e mm	Price list прайс-лист м/у.е.
GKT - 5K AL	0,200	53	9	1	3,40
GKT - 10K AL	0,340	103	9	1	5,80
GKT - 20K AL	0,580	203	9	1	10,00
GKT - 30K AL	0,900	305	9	1	15,00
GKT - 40K AL	1,750	405	9	1,5	30,00
GKT - 50K AL	2,150	505	9	1,5	36,50
GKT - 60K AL	2,600	605	9	1,5	44,00

SEPERATÖR

Seperator

Сепаратор

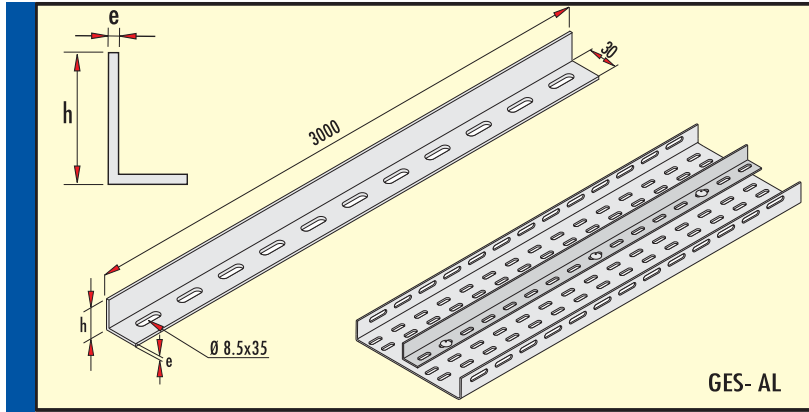

Seperator (5052 ALÜMİNYUM ALAŞIM)  
Separator (5052 Aluminium Alloy)  
Сепаратор

Sipariş kodu Order code Код заявки	Ağırlık (Kg/mt.) Weight (Kg/mt) Вес (кг/м)	h mm	e mm	Price list прайс-лист м/у.е.
GES - 40 AL	0,180	38	1	3,00
GES - 50 AL	0,280	48	1,5	4,76
GES - 60 AL	0,320	58	1,5	5,44
GES - 70 AL	0,380	68	1,5	6,46
GES - 100 AL	0,670	98	2	11,40

KAPAK KELEPÇELERİ (5052 ALÜMİNYUM ALAŞIM)

Cover Clamps (5052 Aluminium Alloy)

Фиксаторы крышки

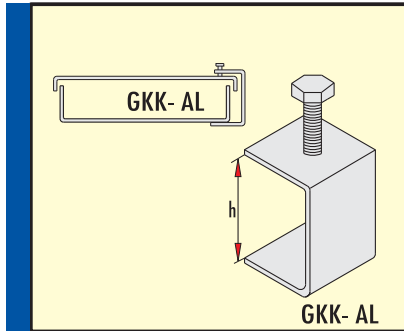

Kapak Kelepçeleri Cover Clamps  
Фиксаторы крышки

Sipariş kodu Order code Код заявки	Ağırlık (Kg/ad.) Weight (Kg/unit) Вес (кг/шт)	h mm	e mm	Price list прайс-лист шт/у.е.
GKK - 45 AL	0,015	45	2	0,33
GKK - 55 AL	0,016	55	2	0,35
GKK - 65 AL	0,020	65	2	0,44
GKK - 75 AL	0,023	75	2	0,50
GKK - 105 AL	0,027	105	2	0,60

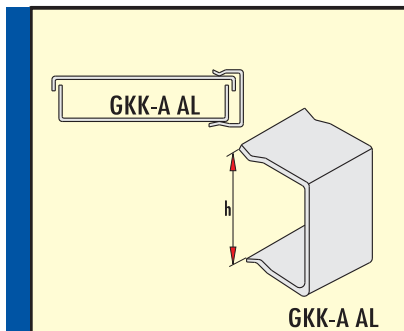
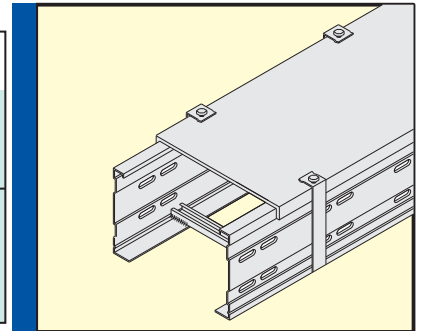

Kapak Kelepçeleri Cover Clamps  
Фиксаторы крышки

Sipariş kodu Order code Код заявки	Ağırlık (Kg/ad.) Weight (Kg/unit) Вес (кг/шт)	h mm	e mm	Price list прайс-лист шт/у.е.
GKK - A45 AL	0,015	45	2	0,33
GKK - A55 AL	0,016	55	2	0,35
GKK - A65 AL	0,018	65	2	0,39
GKK - A75 AL	0,020	75	2	0,44
GKK - A105 AL	0,025	105	2	0,55

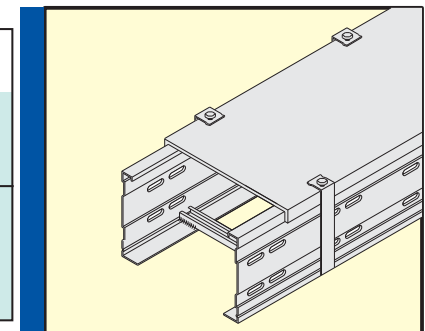



## ALÜMİNYUM PROFİL TAŞIYICI DÖNÜŞ ELEMANLARI

Алюминиевые Изгибы Квартиры Подносов Профиля

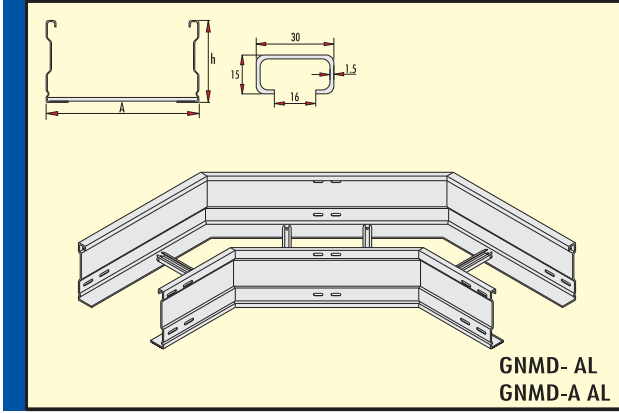

### 90° Dönüş Elemanı (6063 ALÜMİNYUM ALAŞIM)

#### 90° Flat Bend Element (6063 Aluminium Alloy)

90° Квартир Сгибают Элемент (6063 Алюминиевых Сплава)

Sipariş kodu Order code Код заявки	Ağırlık (Kg/ad.) Weight (Kg/unit) Вес (кг/шт)	A mm	h mm	e mm	Price list прайс-лист шт/у.е.
GNMD-20 AL	1,420	200	70	2	28,40
GNMD-30 AL	1,640	300	70	2	32,80
GNMD-40 AL	1,870	400	70	2	37,40
GNMD-50 AL	2,100	500	70	2	42,00
GNMD-60 AL	2,320	600	70	2	46,40
GNMD-A20 AL	1,710	200	100	2	34,20
GNMD-A30 AL	1,970	300	100	2	39,40
GNMD-A40 AL	2,220	400	100	2	44,40
GNMD-A50 AL	2,480	500	100	2	49,60
GNMD-A60 AL	2,730	600	100	2	54,60

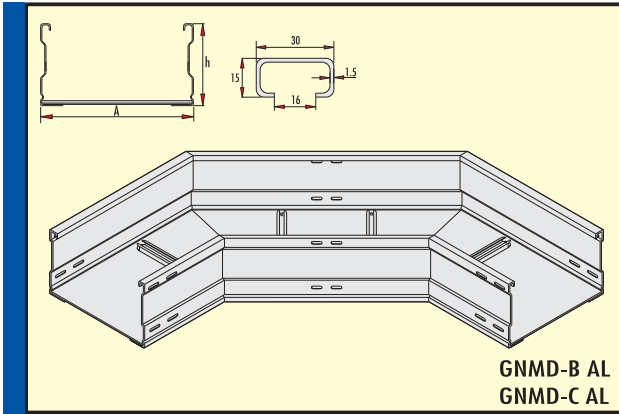

### 90° Dönüş Elemanı (6063 ALÜMİNYUM ALAŞIM)

#### 90° Flat Bend Element (6063 Aluminium Alloy)

90° Квартир Сгибают Элемент (6063 Алюминиевых Сплава)

Sipariş kodu Order code Код заявки	Ağırlık (Kg/ad.) Weight (Kg/unit) Вес (кг/шт)	A mm	h mm	e mm	Price list прайс-лист шт/у.е.
GNMD-B20 AL	2,040	200	70	2	40,80
GNMD-B30 AL	3,260	300	70	2	65,20
GNMD-B40 AL	4,200	400	70	2	84,00
GNMD-B50 AL	5,240	500	70	2	104,80
GNMD-B60 AL	6,360	600	70	2	127,20
GNMD-C20 AL	2,340	200	100	2	46,80
GNMD-C30 AL	3,580	300	100	2	71,60
GNMD-C40 AL	4,550	400	100	2	91,00
GNMD-C50 AL	5,610	500	100	2	112,20
GNMD-C60 AL	6,760	600	100	2	135,20

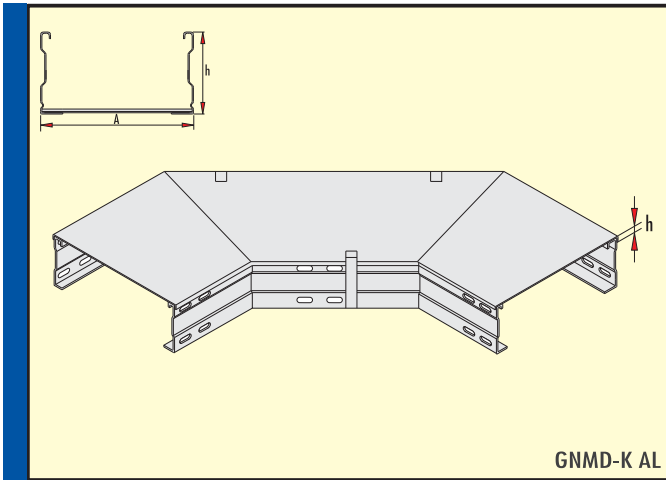

### 90° Dönüş Eleman Kapağı (5052) ALÜMİNYUM ALAŞIM)

#### 90° Flat Bend Element Cover (5052) Aluminium Alloy)

90° Квартир Сгибают Покрытие Элемент (5052) Алюминиевых Сплава)

Sipariş kodu Order code Код заявки	Ağırlık (Kg/ad.) Weight (Kg/unit) Вес (кг/шт)	A mm	h mm	e mm	Price list прайс-лист шт/у.е.
GNMD-20K AL	0,900	200	9	1,5	18,00
GNMD-30K AL	1,400	300	9	1,5	28,00
GNMD-40K AL	2,050	400	9	1,5	41,00
GNMD-50K AL	2,800	500	9	1,5	56,00
GNMD-60K AL	3,550	600	9	1,5	71,00

Malzeme : EN-6063 Alüminyum Alaşım Material : EN-6063 Aluminium Alloy.

Bu tip kablo taşıyıcılarında kullanılan kapak, ek elemanı, taban sacı vb. aksesuarlar EN-5052 alaşım alüminyumdan imal edilir.

Katalogumuzda belirtilen tüm sıcak daldırma galvaniz kablo taşıyıcıları ve aksesuarları istek üzerine EN-5052 alaşım alüminyumdan imal edilebilir.

Covers, jointing pieces, bottom plate and other accessories for EN-6063 aluminium alloy cable trays are produced from EN-5052 aluminium alloy plate.

All hot dip galvanized materials mentioned in our catalog can be produced from EN-5052 aluminium alloy according to the requirements.

Покрытия, соединяющие части, подпочный щиток и other принадлежности для EN-6063 алюминиевых подносов кабеля сплава произведены от 5052 plate сплава алюминия. Гальванизированные материалы всего горячего падения, упомянутые в нашем каталоге могут быть произведены от EN-5052 алюминиевого сплава согласно требованиям.

## ALÜMİNYUM PROFİL TAŞIYICI DÖNÜŞ ELEMANLARI

Алюминиевые Изгибы Квартиры Подносов Профиля

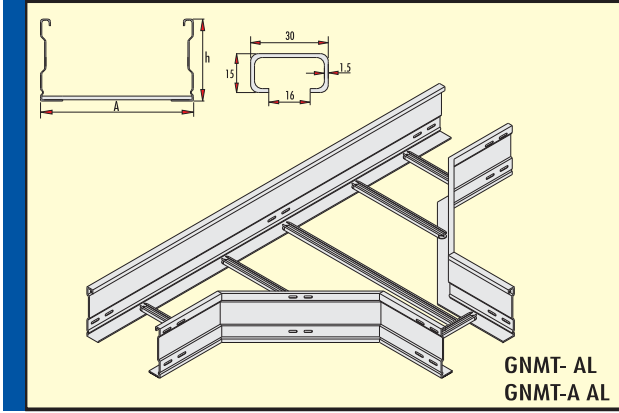

### "T" Bağlantı Elemanı (6063 ALÜMİNYUM ALAŞIM)

#### Tees "T" Element (6063 Aluminium Alloy)

Тис "Т" Элемент (6063 Аллюминиевых Сплава)

Sipariş kodu Order code Код заявки	Ağırlık (Kg/ad.) Weight (Kg/unit) Вес (кг /шт)	A mm	h mm	e mm	Price list прайс-лист шт/у.е.
GNMT-20 AL	2,160	200	70	2	43,20
GNMT-30 AL	2,430	300	70	2	48,60
GNMT-40 AL	2,710	400	70	2	54,20
GNMT-50 AL	2,980	500	70	2	59,60
GNMT-60 AL	3,250	600	70	2	65,00
GNMT-A20 AL	2,570	200	100	2	51,40
GNMT-A30 AL	2,860	300	100	2	57,20
GNMT-A40 AL	3,150	400	100	2	63,00
GNMT-A50 AL	3,440	500	100	2	68,80
GNMT-A60 AL	3,730	600	100	2	74,60

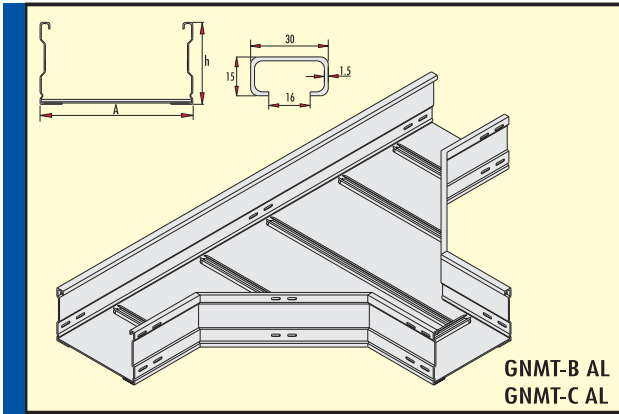

### "T" Bağlantı Elemanı (6063 ALÜMİNYUM ALAŞIM)

#### Tees "T" Element (6063 Aluminium Alloy)

Тис "Т" Элемент (6063 Аллюминиевых Сплава)

Sipariş kodu Order code Код заявки	Ağırlık (Kg/ad.) Weight (Kg/unit) Вес (кг /шт)	A mm	h mm	e mm	Price list прайс-лист шт/у.е.
GNMT-B20 AL	3,920	200	70	2	78,40
GNMT-B30 AL	5,160	300	70	2	103,20
GNMT-B40 AL	6,500	400	70	2	130,00
GNMT-B50 AL	7,950	500	70	2	159,00
GNMT-B60 AL	9,660	600	70	2	193,20
GNMT-C20 AL	4,340	200	100	2	86,80
GNMT-C30 AL	5,590	300	100	2	111,80
GNMT-C40 AL	6,940	400	100	2	138,80
GNMT-C50 AL	8,410	500	100	2	168,20
GNMT-C60 AL	10,140	600	100	2	202,80

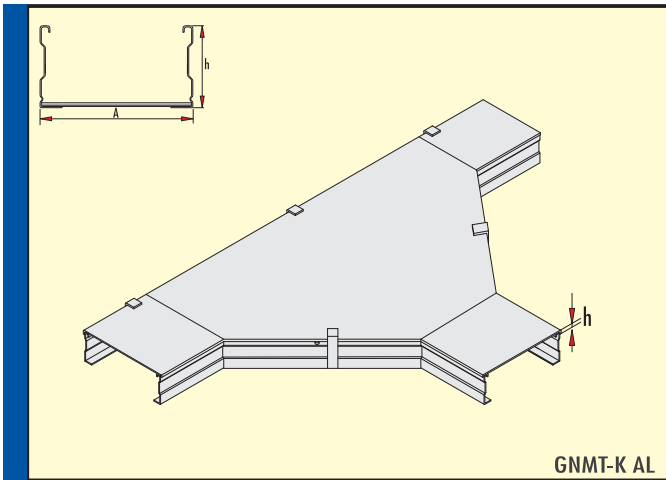

### "T" Bağlantı Eleman Kapağı (5052)ALÜMİNYUM ALAŞIM)

#### Tees "T" Element Cover (5052)Aluminium Alloy)

Тис "Т" Покрывтие Элемент (5052) Аллюминиевых Сплава)

Sipariş kodu Order code Код заявки	Ağırlık (Kg/ad.) Weight (Kg/unit) Вес (кг /шт)	A mm	h mm	e mm	Price list прайс-лист шт/у.е.
GNMT-20 K AL	1,550	200	9	1,5	31,00
GNMT-30 K AL	2,350	300	9	1,5	47,00
GNMT-40 K AL	3,350	400	9	1,5	67,00
GNMT-50 K AL	4,280	500	9	1,5	85,60
GNMT-60 K AL	5,400	600	9	1,5	108,00

Malzeme : EN-6063 Alüminyum Alaşım Material : EN-6063 Aluminium Alloy.

Bu tip kablo taşıyıcılarında kullanılan kapak, ek elemanı, taban sacı vb. aksesuarlar EN-5052 alaşım alüminyumdan imal edilir.

Kataloğumuzda belirtilen tüm sıcak daldırma galvaniz kablo taşıyıcıları ve aksesuarları istek üzerine EN-5052 alaşım alüminyum sacdan imal edilebilir.

Covers, jointing pieces, bottom plate and other accessories for EN-6063 aluminium alloy cable trays are produced from EN-5052 aluminium alloy plate.

All hot dip galvanized materials mentioned in our catalog can be produced from EN-5052 aluminium alloy according to the requirements.

Покрывтия, соединяя части, подпочный щиток и other принадлежности для EN-6063 аллюминиевых подносов кабеля сплава произведены от 5052 plate сплава аллюминия.  
Гальванизированные материалы всего горячего падения, упомянутые в нашем каталоге могут быть произведены от EN-5052 аллюминиевого сплава согласно требованиям.

## ALÜMİNYUM PROFİL TAŞIYICI DÖNÜŞ ELEMANLARI

Алюминиевые Изгибы Квартиры Подносов Профиля

## Aluminium Profile Trays Flat Bend Elements

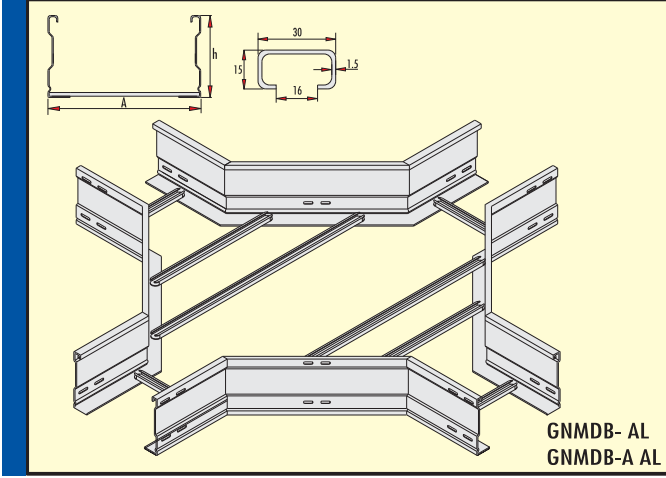

### Dörtlü Bağlantı Elemanı (6063 ALÜMİNYUM ALAŞIM) Crossing Element (6063 Aluminium Alloy)

Пересечение Элемент (6063 Аллюминиевых Сплава)

Sipariş kodu Order code Код заявки	Ağırlık (Kg/ad.) Weight (Kg/unit) Вес (кг / шт)	A mm	h mm	e mm	Price list прайс-лист шт / у.е.
GNMDB-20 AL	2,830	200	70	2	56,60
GNMDB-30 AL	3,100	300	70	2	62,00
GNMDB-40 AL	3,370	400	70	2	67,40
GNMDB-50 AL	3,430	500	70	2	68,60
GNMDB-60 AL	3,670	600	70	2	73,40
GNMDB-A20 AL	3,310	200	100	2	66,20
GNMDB-A30 AL	3,580	300	100	2	71,60
GNMDB-A40 AL	3,850	400	100	2	77,00
GNMDB-A50 AL	3,920	500	100	2	78,40
GNMDB-A60 AL	4,160	600	100	2	83,20

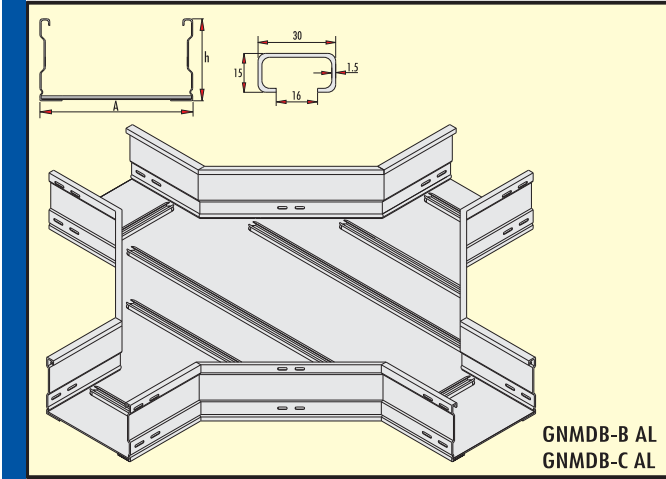

### Dörtlü Bağlantı Elemanı (6063 ALÜMİNYUM ALAŞIM) Crossing Element (6063 Aluminium Alloy)

Пересечение Элемент (6063 Аллюминиевых Сплава)

Sipariş kodu Order code Код заявки	Ağırlık (Kg/ad.) Weight (Kg/unit) Вес (кг / шт)	A mm	h mm	e mm	Price list прайс-лист шт / у.е.
GNMDB-B20 AL	5,220	200	70	2	104,40
GNMDB-B30 AL	6,690	300	70	2	133,80
GNMDB-B40 AL	8,240	400	70	2	164,80
GNMDB-B50 AL	9,720	500	70	2	194,40
GNMDB-B60 AL	11,470	600	70	2	229,40
GNMDB-C20 AL	5,700	200	100	2	114,00
GNMDB-C30 AL	7,170	300	100	2	143,40
GNMDB-C40 AL	8,730	400	100	2	174,60
GNMDB-C50 AL	10,200	500	100	2	204,00
GNMDB-C60 AL	11,950	600	100	2	239,00

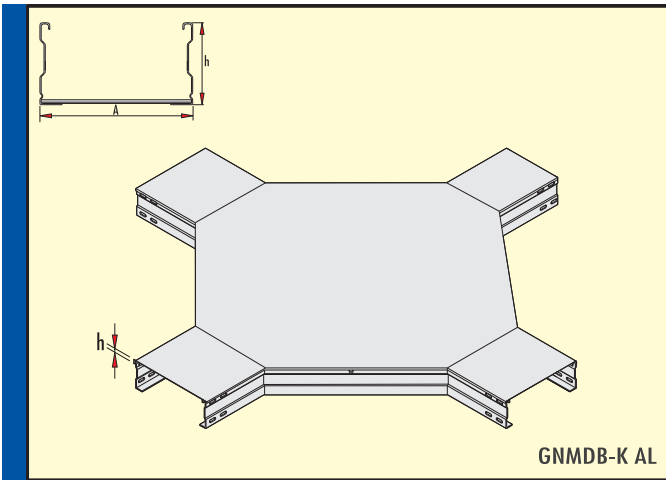

### Dörtlü Bağlantı Eleman Kapağı (5052)ALÜMİNYUM ALAŞIM) Crossing Element Cover (5052)Aluminium Alloy)

Пересечение Покрытие Элемент (5052)Аллюминиевых Сплава)

Sipariş kodu Order code Код заявки	Ağırlık (Kg/ad.) Weight (Kg/unit) Вес (кг / шт)	A mm	h mm	e mm	Price list прайс-лист шт / у.е.
GNMDB-20K AL	2,500	200	9	1,5	50,00
GNMDB-30K AL	3,050	300	9	1,5	61,00
GNMDB-40K AL	4,100	400	9	1,5	82,00
GNMDB-50K AL	5,300	500	9	1,5	106,00
GNMDB-60K AL	6,500	600	9	1,5	130,00

Malzeme : EN-6063 Alüminyum Alaşım Material : EN-6063 Aluminium Alloy.

Bu tip kablo taşıyıcılarında kullanılan kapak, ek elemanı, taban sacı vb. aksesuarlar EN-5052 alaşım alüminyumdan imal edilir.

Kataloğumuzda belirtilen tüm sıcak daldırma galvaniz kablo taşıyıcıları ve aksesuarları istek üzerine EN-5052 alaşım alüminyum sacdan imal edilebilir.

Covers, jointing pieces, bottom plate and other accessories for EN-6063 aluminium alloy cable trays are produced from EN-5052 aluminium alloy plate.

All hot dip galvanized materials mentioned in our catalog can be produced from EN-5052 aluminium alloy according to the requirements.

Покрытия, соединяющие части, подпочный щиток и other принадлежности для EN-6063 аллюминиевых подносов кабеля сплава произведены от 5052 plate сплава аллюминия. Гальванизи ованные мате иалы всего го ячего падения, упомянутые в нашем каталоге могут быть п оизведены от EN-5052 аллюминиевого сплава согласно т ебованиям.



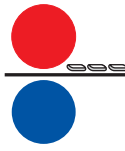

## ALÜMİNYUM PROFİL TAŞIYICI DÖNÜŞ ELEMANLARI

Алюминиевые Изгибы Квартитры Подносов Профиля

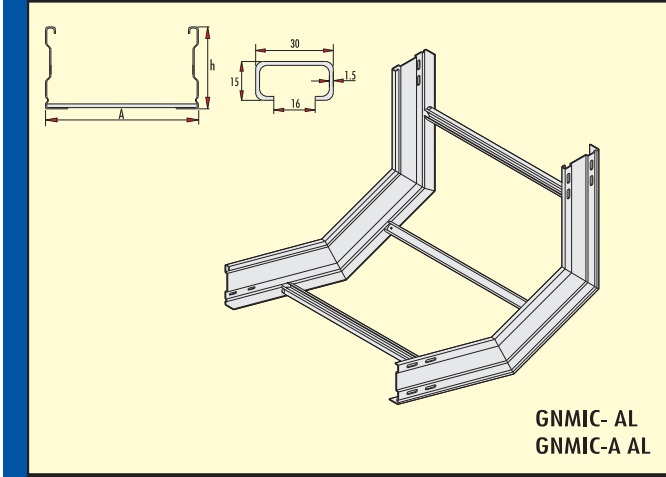

### İç Bükey Elemanı (6063 ALÜMİNYUM ALAŞIM)

#### Inside Vertical Element (6063 Aluminium Alloy)

В Вертикальном Элемент (6063 Алюминиевых Сплава)

Sipariş kodu Order code Код заявки	Ağırlık (Kg/ad.) Weight (Kg/unit) Вес (кг / шт)	A mm	h mm	e mm	Price list прайс-лист шт/у.е.
GNMIC-20 AL	1,350	200	70	2	27,00
GNMIC-30 AL	1,440	300	70	2	28,80
GNMIC-40 AL	1,530	400	70	2	30,60
GNMIC-50 AL	1,620	500	70	2	32,40
GNMIC-60 AL	1,710	600	70	2	34,20
GNMIC-A20 AL	1,650	200	100	2	33,00
GNMIC-A30 AL	1,740	300	100	2	34,80
GNMIC-A40 AL	1,830	400	100	2	36,60
GNMIC-A50 AL	1,920	500	100	2	38,40
GNMIC-A60 AL	2,010	600	100	2	40,20

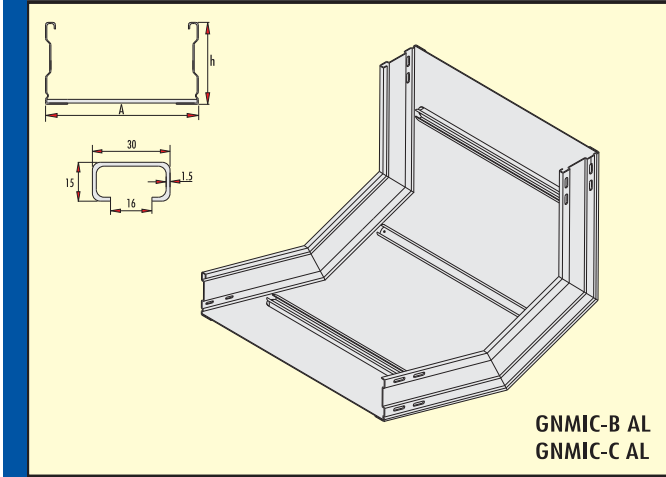

### İç Bükey Elemanı (6063 ALÜMİNYUM ALAŞIM)

#### Inside Vertical Element (6063 Aluminium Alloy)

В Вертикальном Элемент (6063 Алюминиевых Сплава)

Sipariş kodu Order code Код заявки	Ağırlık (Kg/ad.) Weight (Kg/unit) Вес (кг / шт)	A mm	h mm	e mm	Price list прайс-лист шт/у.е.
GNMIC-B20 AL	2,340	200	70	2	46,80
GNMIC-B30 AL	2,920	300	70	2	58,40
GNMIC-B40 AL	3,510	400	70	2	70,20
GNMIC-B50 AL	4,100	500	70	2	82,00
GNMIC-B60 AL	4,670	600	70	2	93,40
GNMIC-C20 AL	2,640	200	100	2	52,80
GNMIC-C30 AL	3,220	300	100	2	64,40
GNMIC-C40 AL	3,800	400	100	2	76,00
GNMIC-C50 AL	4,390	500	100	2	87,80
GNMIC-C60 AL	4,970	600	100	2	99,40

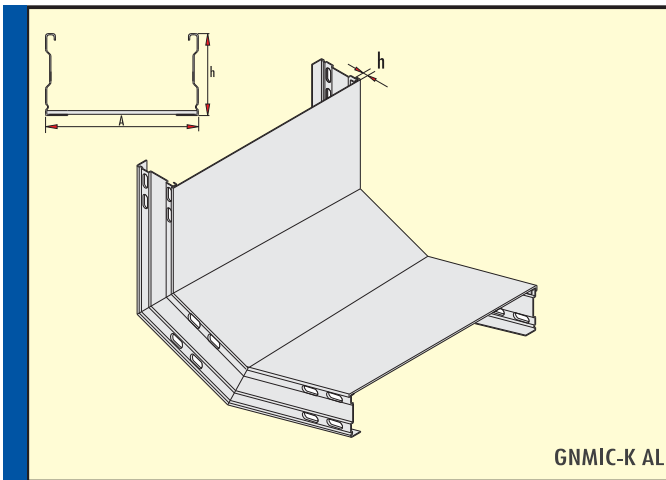

### İç Bükey Eleman Kapağı (5052) ALÜMİNYUM ALAŞIM)

#### Inside Vertical Element Cover (5052) Aluminium Alloy)

В Вертикальном Покрытие Элемент (5052) Алюминиевых Сплава)

Sipariş kodu Order code Код заявки	Ağırlık (Kg/ad.) Weight (Kg/unit) Вес (кг / шт)	A mm	h mm	e mm	Price list прайс-лист шт/у.е.
GNMIC-20K AL	0,700	200	70	1,5	14,00
GNMIC-30K AL	1,050	300	70	1,5	21,00
GNMIC-40K AL	1,400	400	70	1,5	28,00
GNMIC-50K AL	1,700	500	70	1,5	34,00
GNMIC-60K AL	2,050	600	70	1,5	41,00

Malzeme : EN-6063 Alüminyum Alaşım Material : EN-6063 Aluminium Alloy.

Bu tip kablo taşıyıcılarında kullanılan kapak, ek elemanı, taban sacı vb. aksesuarlar EN-5052 alaşım alüminyumdan imal edilir.

Katalogumuzda belirtilen tüm sıcak daldırma galvaniz kablo taşıyıcıları ve aksesuarları istek üzerine EN-5052 alaşım alüminyumdan imal edilebilir.

Covers, jointing pieces, bottom plate and other accessories for EN-6063 aluminium alloy cable trays are produced from EN-5052 aluminium alloy plate.

All hot dip galvanized materials mentioned in our catalog can be produced from EN-5052 aluminium alloy according to the requirements.

Покрытия, соединяющие части, подпочный щиток и other принадлежности для EN-6063 алюминиевых подносов кабеля сплава произведены от 5052 plate сплава алюминия. Гальванизированные материалы всего горячего падения, упомянутые в нашем каталоге могут быть произведены от EN-5052 алюминиевого сплава согласно требованиям.

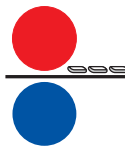

## ALÜMİNYUM PROFİL TAŞIYICI DÖNÜŞ ELEMANLARI

## Aluminium Profile Trays Flat Bend Elements

Алюминиевые Изгибы Квартыры Подносов Профиля

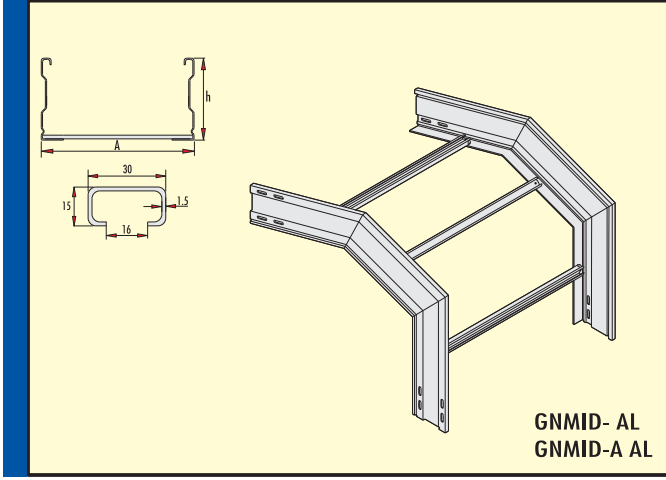

### Dış Bükme Elemanı (6063 ALÜMİNYUM ALAŞIM)

#### Outside Vertical Element (6063 Aluminium Alloy)

Вне Вертикального Элемент (6063 Алюминиевых Сплава)

Sipariş kodu Order code Код заявки	Ağırlık (Kg/ad.) Weight (Kg/unit) Вес (кг/шт)	A mm	h mm	e mm	Price list прайс-лист шт/у.е.
GNMID-20 AL	1,350	200	70	2	27,00
GNMID-30 AL	1,440	300	70	2	28,80
GNMID-40 AL	1,530	400	70	2	30,60
GNMID-50 AL	1,620	500	70	2	32,40
GNMID-60 AL	1,710	600	70	2	34,20
GNMID-A20 AL	1,650	200	100	2	33,00
GNMID-A30 AL	1,740	300	100	2	34,80
GNMID-A40 AL	1,830	400	100	2	36,60
GNMID-A50 AL	1,920	500	100	2	38,40
GNMID-A60 AL	2,010	600	100	2	40,20

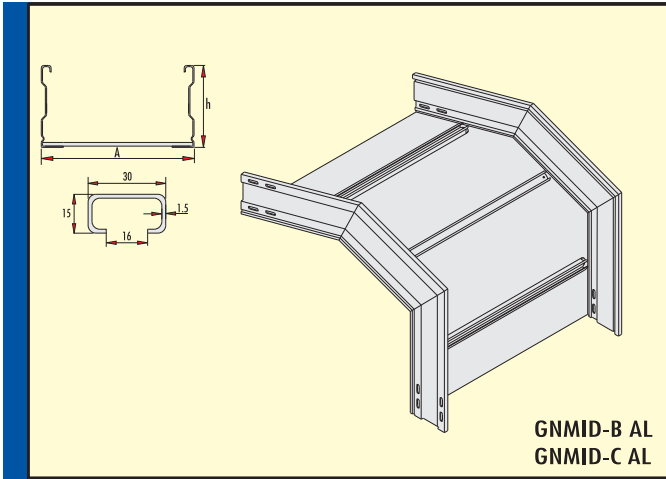

### Dış Bükme Elemanı (6063 ALÜMİNYUM ALAŞIM)

#### Outside Vertical Element (6063 Aluminium Alloy)

Вне Вертикального Элемент (6063 Алюминиевых Сплава)

Sipariş kodu Order code Код заявки	Ağırlık (Kg/ad.) Weight (Kg/unit) Вес (кг/шт)	A mm	h mm	e mm	Price list прайс-лист шт/у.е.
GNMID-B20 AL	2,340	200	70	2	46,80
GNMID-B30 AL	2,920	300	70	2	58,40
GNMID-B40 AL	3,510	400	70	2	70,20
GNMID-B50 AL	4,100	500	70	2	82,00
GNMID-B60 AL	4,670	600	70	2	93,40
GNMID-C20 AL	2,640	200	100	2	52,80
GNMID-C30 AL	3,220	300	100	2	64,40
GNMID-C40 AL	3,800	400	100	2	76,00
GNMID-C50 AL	4,390	500	100	2	87,80
GNMID-C60 AL	4,970	600	100	2	99,40

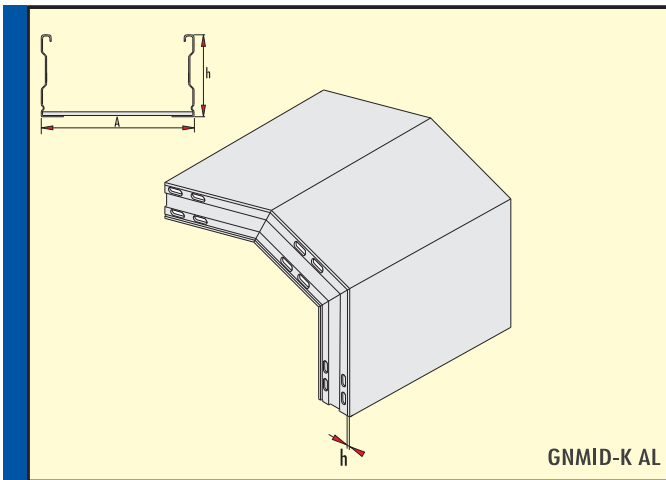

### Dış Bükme Eleman Kapağı (5052) ALÜMİNYUM ALAŞIM

#### Outside Vertical Element Cover (5052) Aluminium Alloy

Вне Вертикального Покрытие Элемент (5052) Алюминиевых Сплава)

Sipariş kodu Order code Код заявки	Ağırlık (Kg/ad.) Weight (Kg/unit) Вес (кг/шт)	A mm	h mm	e mm	Price list прайс-лист шт/у.е.
GNMID - 20K AL	0,850	200	9	1,5	17,00
GNMID - 30K AL	1,250	300	9	1,5	25,00
GNMID - 40K AL	1,650	400	9	1,5	33,00
GNMID - 50K AL	2,050	500	9	1,5	41,00
GNMID - 60K AL	2,400	600	9	1,5	48,00

Malzeme : EN-6063 Alüminyum Alaşım Material : EN-6063 Aluminium Alloy.

Bu tip kablo taşıyıcılarında kullanılan kapak, ek elemanı, taban sacı vb. aksesuarlar EN-5052 alaşım alüminyumdan imal edilir.

Kataloğumuzda belirtilen tüm sıcak daldırma galvaniz kablo taşıyıcıları ve aksesuarları istek üzerine EN-5052 alaşım alüminyum sacdan imal edilebilir.

Covers, jointing pieces, bottom plate and other accessories for EN-6063 aluminium alloy cable trays are produced from EN-5052 aluminium alloy plate.

All hot dip galvanized materials mentioned in our catalog can be produced from EN-5052 aluminium alloy according to the requirements.

Покрyтия, соединяющие части, подпочный щиток и other принадлежности для EN-6063 алюминиевых подносов кабеля сплава произведены от 5052 plate сплава алюминия. Гальванизированные материалы всего горячего падения, упомянутые в нашем каталоге могут быть произведены от EN-5052 алюминиевого сплава согласно требованиям.

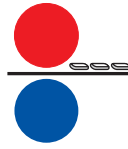

## ALÜMİNYUM PROFİL TAŞIYICI DÖNÜŞ ELEMANLARI

## Aluminium Profile Trays Flat Bend Elements

Алюминиевые Изгибы Квартиры Подносов Профиля

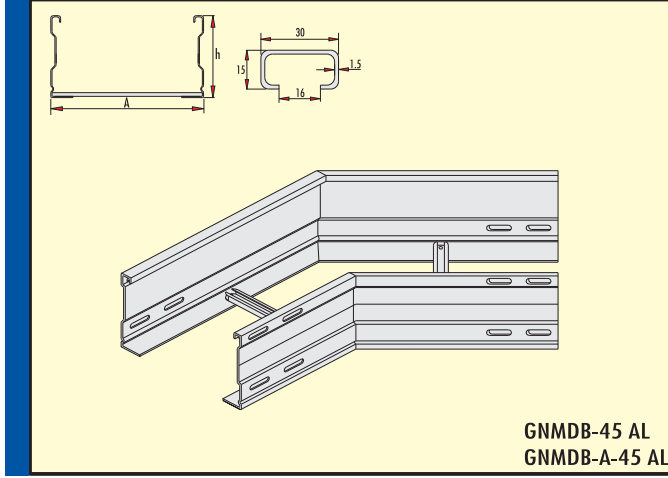

### 135° Dönüş Elemanı (6063 ALÜMİNYUM ALAŞIM)

### 135° Flat Bend Element (6063 Aluminium Alloy)

135° Квартир Сгибают Элемент (6063 Аллюминиевых Сплава)

Sipariş kodu Order code Код заявки	Ağırlık (Kg/ad.) Weight (Kg/unit) Вес (кг/шт)	A mm	h mm	e mm	Price list прайс-лист шт/у.е.
GNMID-20-45 AL	0,930	200	70	2	18,60
GNMID-30-45 AL	1,070	300	70	2	21,40
GNMID-40-45 AL	1,220	400	70	2	24,40
GNMID-50-45 AL	1,390	500	70	2	27,80
GNMID-60-45 AL	1,500	600	70	2	30,00
GNMID-A20-45 AL	1,120	200	100	2	22,40
GNMID-A30-45 AL	1,270	300	100	2	25,40
GNMID-A40-45 AL	1,430	400	100	2	28,60
GNMID-A50-45 AL	1,590	500	100	2	31,80
GNMID-A60-45 AL	1,740	600	100	2	34,80

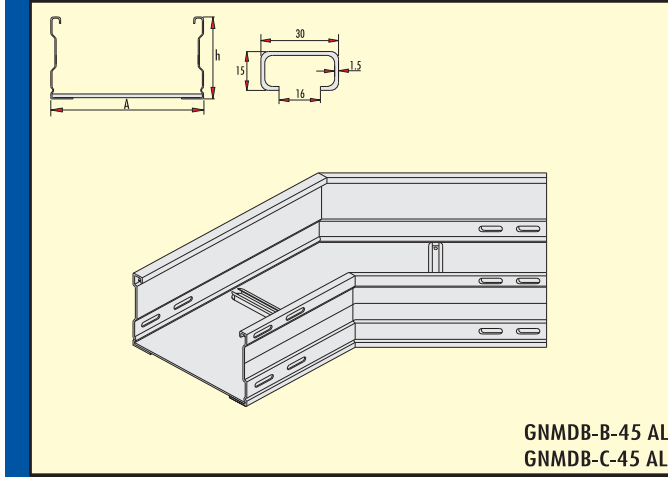

### 135° Dönüş Elemanı (6063 ALÜMİNYUM ALAŞIM)

### 135° Flat Bend Element (6063 Aluminium Alloy)

135° Квартир Сгибают Элемент (6063 Аллюминиевых Сплава)

Sipariş kodu Order code Код заявки	Ağırlık (Kg/ad.) Weight (Kg/unit) Вес (кг/шт)	A mm	h mm	e mm	Price list прайс-лист шт/у.е.
GNMID-B20-45 AL	1,560	200	70	2	31,20
GNMID-B30-45 AL	2,100	300	70	2	42,00
GNMID-B40-45 AL	2,650	400	70	2	53,00
GNMID-B50-45 AL	3,300	500	70	2	66,00
GNMID-B60-45 AL	3,580	600	70	2	71,60
GNMID-C20-45 AL	1,750	200	100	2	35,00
GNMID-C30-45 AL	2,280	300	100	2	45,60
GNMID-C40-45 AL	2,870	400	100	2	57,40
GNMID-C50-45 AL	3,500	500	100	2	70,00
GNMID-C60-45 AL	4,170	600	100	2	83,40

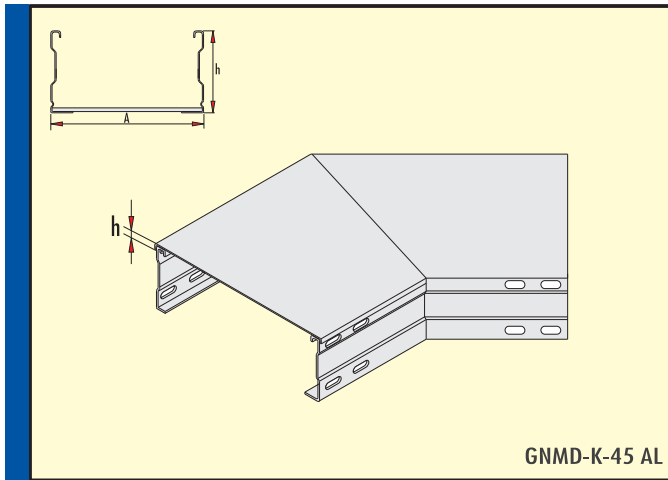

### 135° Dönüş Eleman Kapağı (5052 ALÜMİNYUM ALAŞIM)

### 135° Flat Bend Element Cover (5052 Aluminium Alloy)

135° Квартир Сгибают Покрытие Элемент (5052 Аллюминиевых Сплава)

Sipariş kodu Order code Код заявки	Ağırlık (Kg/ad.) Weight (Kg/unit) Вес (кг/шт)	A mm	h mm	e mm	Price list прайс-лист шт/у.е.
GNMD-20K-45 AL	0,500	200	9	1,5	10,00
GNMD-30K-45 AL	0,800	300	9	1,5	16,00
GNMD-40K-45 AL	1,050	400	9	1,5	21,00
GNMD-50K-45 AL	1,450	500	9	1,5	29,00
GNMD-60K-45 AL	1,800	600	9	1,5	36,00

Malzeme : EN-6063 Alüminyum Alaşım Material : EN-6063 Aluminium Alloy.

Bu tip kablo taşıyıcılarında kullanılan kapak, ek elemanı, taban sacı vb. aksesuarlar EN-5052 alaşım alüminyumdan imal edilir.

Kataloğumuzda belirtilen tüm sıcak daldırma galvaniz kablo taşıyıcıları ve aksesuarları istek üzerine EN-5052 alaşım alüminyum sacdan imal edilebilir.

Covers, jointing pieces, bottom plate and other accessories for EN-6063 aluminium alloy cable trays are produced from EN-5052 aluminium alloy plate.

All hot dip galvanized materials mentioned in our catalog can be produced from EN-5052 aluminium alloy according to the requirements.

Покрyтия, соединяющие части, подопычный щиток и другие принадлежности для EN-6063 аллюминиевых подносов кабеля сплава произведены от 5052 плoте сплава аллюминия. Гальванизированные материалы всего горячего падения, упомянутые в нашем каталоге могут быть произведены от EN-5052 аллюминиевого сплава согласно требованиям.

## CIVATA TAKIMLARI

## Screw Sets

## Комплект винтового соединения

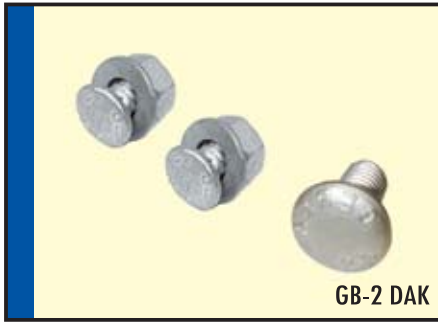

GB-2 DAK

Kaplama: Geomet  
Coating: Geomet

### Cıvata Takımı Screw Set

Комплект винтового соединения

Sipariş kodu Order code Код заявки	Ağırlık (Kg/ık) Weight (Kg/set) Вес (К-кт/шт)	D mm	Price list прайс-лист К-кт/у.е.
GB-2 DAK	0,014	M8X15	0,17
GB-2 E	0,014	M8X15	0,17



GB-2 E

Kaplama : TS 149 Elektro Galvaniz  
Coating : TS 149 Electro Galvanized (Turkish Standart)



GB-2 İNOX

Malzeme : 304 (SS 304) Kalite Paslanmaz Çelik (Cr-Ni)

### Cıvata Takımı Paslanmaz Çelik (Cr-Ni) Screw Set Stainless Steel (Cr-Ni)

Комплект винтового соединения

Sipariş kodu Order code Код заявки	Ağırlık (Kg/ık) Weight (Kg/set) Вес (К-кт/шт)	D mm	Price list прайс-лист К-кт/у.е.
GB-2 İNOX	0,014	M8X15	0,45



Material : 304 Quality (SS 304) Stainless Steel (Cr-Ni)

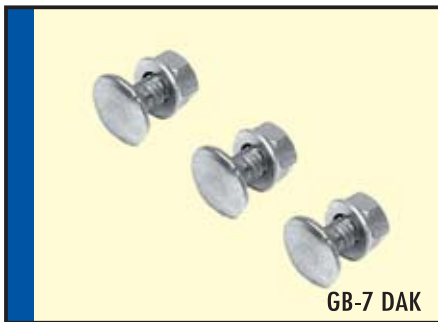

GB-7 DAK

Kaplama: Geomet  
Coating: Geomet

### Cıvata Takımı Screw Set

Комплект винтового соединения

Sipariş kodu Order code Код заявки	Ağırlık (Kg/ık) Weight (Kg/set) Вес (К-кт/шт)	D mm	Price list прайс-лист К-кт/у.е.
GB-7 DAK	0,010	M6X15	0,12
GB-7 E	0,010	M6X15	0,12

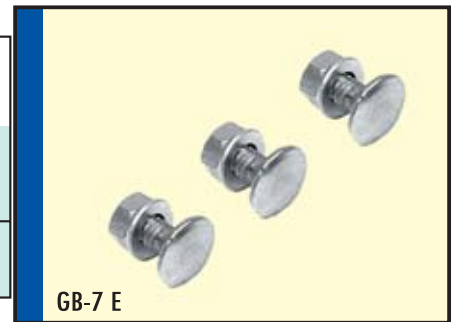

GB-7 E

Kaplama : TS 149 Elektro Galvaniz  
Coating : TS 149 Electro Galvanized (Turkish Standart)



GB-1 E

Kaplama : TS 149 Elektro Galvaniz  
Coating : TS 149 Electro Galvanized (Turkish Standart)

### 8x80 Kopilya 8x80 Pin Шплинт

Sipariş kodu Order code Код заявки	Ağırlık (Kg/ad.) Weight (Kg/unit) Вес (кг/шт)	D mm	Price list прайс-лист шт/у.е.
GB-1 E	0,028	8x80	0,25
GB-1 P	0,028	8x80	0,95

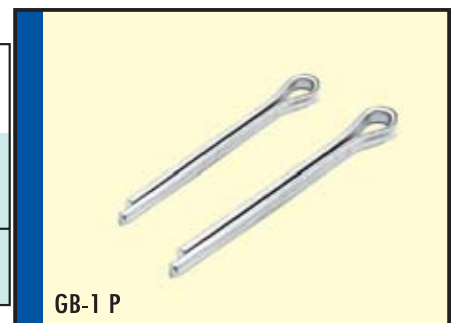

GB-1 P

Malzeme : 304 (SS 304) Kalite Paslanmaz Çelik (Cr-Ni)  
Material : 304 Quality (SS 304) Stainless Steel (Cr-Ni)



**ASKI TİJLERİ**

**Threaded Rods**

**Шпилька**

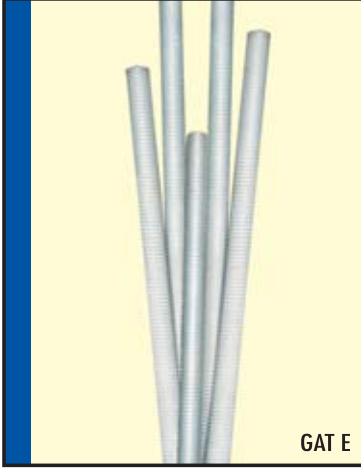

GAT E

Kaplama : TS 149 Elektro Galvaniz  
Coating : TS 149 Electro Galvanized  
(Turkish Standart)

Tij (DIN 975) Threaded Rod (DIN 975) Шпилька				
Sipariş kodu Order code Код заявки	Ağırlık (Kg/ad.) Weight (Kg/unit) Вес (кг/шт)	D mm	L mm	Price list прайс-лист шт/у.е.
GAT -500 E	0,150	M8	500	0,75
GAT -1000 E	0,300	M8	1000	1,50
GAT -2000 E	0,600	M8	2000	3,10
GAT -3000 E	0,900	M8	3000	4,75
GAT -500-A E	0,230	M10	500	1,30
GAT -1000-A E	0,450	M10	1000	2,50
GAT -2000-A E	0,900	M10	2000	5,00
GAT -3000-A E	1,350	M10	3000	7,50
GAT -500-B E	0,350	M12	500	1,80
GAT -1000-B E	0,690	M12	1000	3,50
GAT -2000-B E	1,380	M12	2000	7,00
GAT -3000-B E	2,070	M12	3000	10,60
GAT -1000-C E	0,170	M6	1000	1,05
GAT -2000-C E	0,340	M6	2000	2,10

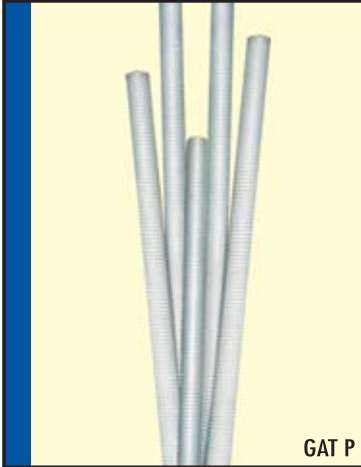

GAT P

Malzeme : 304-316 (SS 304-316) Kalite  
Paslanmaz Çelik (Cr-Ni)  
Material : 304-316 Quality (SS 304-316)  
Stainless Steel (Cr-Ni)

Tij Paslanmaz Çelik (Cr-Ni) Threaded Rod Stainless Steel (Cr-Ni) Шпилька				
Sipariş kodu Order code Код заявки	Ağırlık (Kg/ad.) Weight (Kg/unit) Вес (кг/шт)	D mm	L mm	Price list прайс-лист шт/у.е.
GAT -500 P	0,150	M8	500	4,50
GAT -1000 P	0,300	M8	1000	8,00
GAT -2000 P	0,600	M8	2000	19,60
GAT -3000 P	0,900	M8	3000	29,00
GAT -500-A P	0,230	M10	500	6,50
GAT -1000-A P	0,450	M10	1000	12,00
GAT -2000-A P	0,900	M10	2000	32,00
GAT -3000-A P	1,350	M10	3000	49,00
GAT -500-B P	0,350	M12	500	10,00
GAT -1000-B P	0,690	M12	1000	18,50
GAT -2000-B P	1,380	M12	2000	45,00
GAT -3000-B P	2,070	M12	3000	68,00
GAT -1000-C P	0,170	M6	1000	4,50
GAT -2000-C P	0,340	M6	2000	12,65



GB-50 E

Kaplama : TS 149 Elektro Galvaniz  
Coating : TS 149 Electro Galvanized (Turkish Standart)

Tij Uzatma Somunu (DIN 6334) Coupler (DIN 6334) Удлиненная гайка			
Sipariş kodu Order code Код заявки	Ağırlık (Kg/ad.) Weight (Kg/unit) Вес (кг/шт)	D mm	Price list прайс-лист шт/у.е.
GB-50 E	0,030	M6	0.42
GB-51 E	0,032	M8	0.45
GB-52 E	0,034	M10	0.48
GB-53 E	0,046	M12	0.65

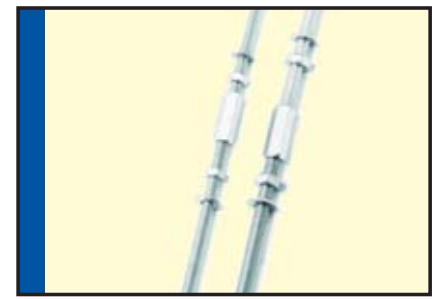

GB-50 P

Malzeme : 304 (SS 304) Kalite Paslanmaz Çelik (Cr-Ni)  
Material : 304 Quality (SS 304) Stainless Steel (Cr-Ni)

Tij Uzatma Somunu Paslanmaz Çelik (Cr-Ni) Coupler Stainless Steel (Cr-Ni) Удлиненная гайка			
Sipariş kodu Order code Код заявки	Ağırlık (Kg/ad.) Weight (Kg/unit) Вес (кг/шт)	D mm	Price list прайс-лист шт/у.е.
GB-50 P	0,030	M6	3,75
GB-51 P	0,032	M8	4,30
GB-52 P	0,034	M10	5,68
GB-53 P	0,046	M12	6,63



## BAĞLANTI ELEMANLARI

## Fixing Elements

## Установка Элемента

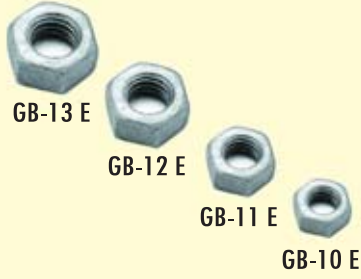

### Somun (DIN 934) Hex Nut (DIN 934)

Гайка

Sipariş kodu Order code Код заявки	Ağırlık (Kg/ad.) Weight (Kg/unit)	D mm	Price list прайс-лист шт./у.е.
GB-10 E	0,002	M6	0,025
GB-11 E	0,005	M8	0,050
GB-12 E	0,010	M10	0,110
GB-13 E	0,016	M12	0,165
GB-11-1 E	0,008	M8	0,085
GB-12-1 E	0,014	M10	0,145



Kaplama : TS 149 Elektro Galvaniz Coating : TS 149 Electro Galvanized (Turkish Standart)  
İsteğe Bağlı Olarak Geomet Kaplama Yapılır. Geomet coated is applied due to request.

Покрытый Geomet применен должный просить

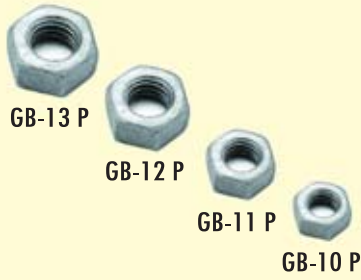

### Somun Paslanmaz Çelik (Cr-Ni)

Hex Nut Stainless Steel (Cr-Ni) Гайка

Sipariş kodu Order code Код заявки	Ağırlık (Kg/ad.) Weight (Kg/unit)	D mm	Price list прайс-лист шт./у.е.
GB-10 P	0,002	M6	0,080
GB-11 P	0,005	M8	0,150
GB-12 P	0,010	M10	0,335
GB-13 P	0,016	M12	0,485
GB-11-1 P	0,008	M8	0,340
GB-12-1 P	0,014	M10	0,630



Malzeme : 304-316 (SS 304-316) Kalite Paslanmaz Çelik (Cr-Ni) Material : 304-316 Quality (SS 304-316) Stainless Steel (Cr-Ni)

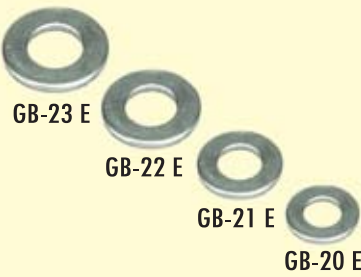

### Pul (DIN 125-1A)

Plain Washer (DIN 125-1A) Шайба

Sipariş kodu Order code Код заявки	Ağırlık (Kg/ad.) Weight (Kg/unit)	D mm	Price list прайс-лист шт./у.е.
GB-20 E	0,001	M6	0,015
GB-21 E	0,002	M8	0,020
GB-22 E	0,004	M10	0,033
GB-23 E	0,007	M12	0,045



Kaplama : TS 149 Elektro Galvaniz Coating : TS 149 Electro Galvanized (Turkish Standart)  
İsteğe Bağlı Olarak Geomet Kaplama Yapılır. Geomet coated is applied due to request.

Покрытый Geomet применен должный просить

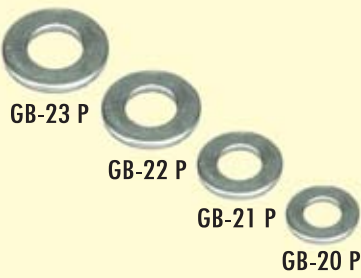

### Pul Paslanmaz Çelik (Cr-Ni)

Plain Washer Stainless Steel (Cr-Ni) Шайба

Sipariş kodu Order code Код заявки	Ağırlık (Kg/ad.) Weight (Kg/unit)	D mm	Price list прайс-лист шт./у.е.
GB-20 P	0,001	M6	0,035
GB-21 P	0,002	M8	0,055
GB-22 P	0,004	M10	0,120
GB-23 P	0,007	M12	0,220



Malzeme : 304-316 (SS 304-316) Kalite Paslanmaz Çelik (Cr-Ni) Material : 304-316 Quality (SS 304-316) Stainless Steel (Cr-Ni)

## BAĞLANTI ELEMANLARI

## Fixing Elements

## Установка Элемента

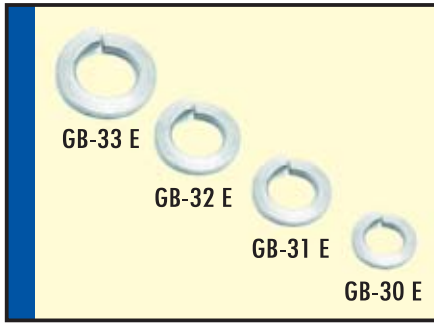

### Yaylı Rondela (DIN 127B) Stringed Washer (DIN 127B)

Шайба пружинная

Sipariş kodu Order code Код заявки	Ağırlık (Kg/ad.) Weight (Kg/unit) Вес (кг/шт)	D mm	Price list прайс-лист шт/у.е.
GB-30 E	0,006	M6	0,015
GB-31 E	0,008	M8	0,020
GB-32 E	0,010	M10	0,033
GB-33 E	0,020	M12	0,045

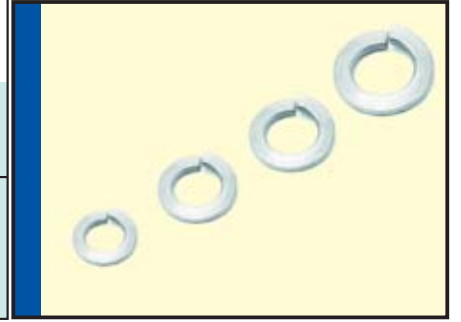

Kaplama : TS 149 Elektro Galvaniz *Coating : TS 149 Electro Galvanized (Turkish Standart)*

İsteğe Bağlı Olarak Geomet Kaplama Yapılır.

*Geomet coated is applied due to request.*

Покрытый Geomet применен должный просить

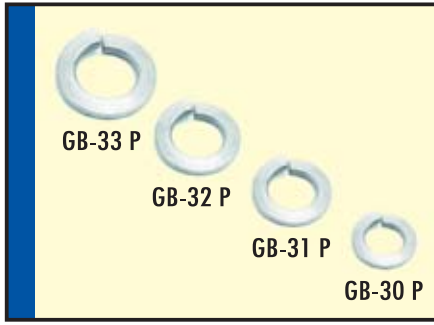

### Yaylı Rondela Paslanmaz Çelik (Cr-Ni) Stringed Washer Stainless Steel (Cr-Ni)

Шайба пружинная

Sipariş kodu Order code Код заявки	Ağırlık (Kg/ad.) Weight (Kg/unit) Вес (кг/шт)	D mm	Price list прайс-лист шт/у.е.
GB-30 P	0,006	M6	0,035
GB-31 P	0,008	M8	0,055
GB-32 P	0,010	M10	0,120
GB-33 P	0,020	M12	0,220

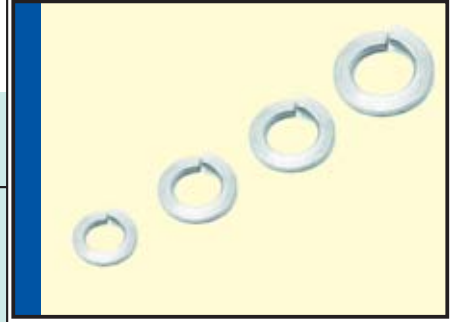

Malzeme : 304-316 (SS 304-316) Kalite Paslanmaz Çelik (Cr-Ni) *Material : 304-316 Quality (SS 304-316) Stainless Steel (Cr-Ni)*

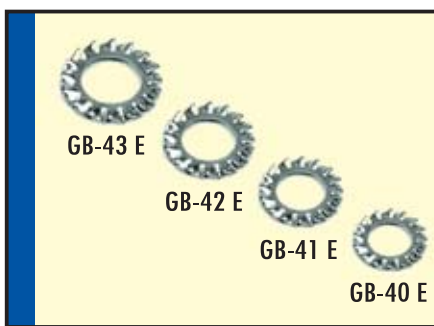

### Tırtıllı Pul (DIN 127B)

### Jagged Washer (DIN 127B)

Зубчатая шайба

Sipariş kodu Order code Код заявки	Ağırlık (Kg/ad.) Weight (Kg/unit) Вес (кг/шт)	D mm	Price list прайс-лист шт/у.е.
GB-40 E	0,004	M6	0,015
GB-41 E	0,006	M8	0,020
GB-42 E	0,010	M10	0,033
GB-43 E	0,016	M12	0,045

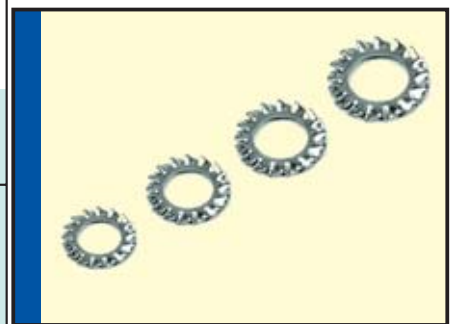

Kaplama : TS 149 Elektro Galvaniz *Coating : TS 149 Electro Galvanized (Turkish Standart)*

İsteğe Bağlı Olarak Geomet Kaplama Yapılır.

*Geomet coated is applied due to request.*

Покрытый Geomet применен должный просить

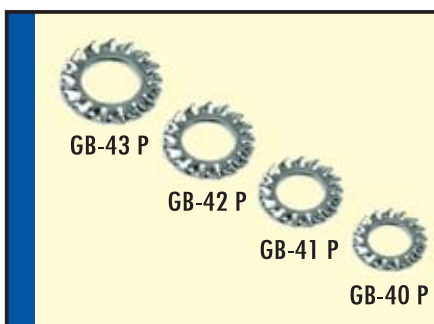

### Tırtıllı Pul Paslanmaz Çelik (Cr-Ni)

### Jagged Washer Stainless Steel (Cr-Ni)

Зубчатая шайба

Sipariş kodu Order code Код заявки	Ağırlık (Kg/ad.) Weight (Kg/unit) Вес (кг/шт)	D mm	Price list прайс-лист шт/у.е.
GB-40 P	0,004	M6	0,035
GB-41 P	0,006	M8	0,055
GB-42 P	0,010	M10	0,120
GB-43 P	0,016	M12	0,220

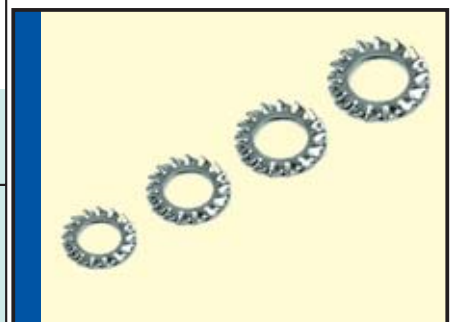

Malzeme : 304-316 (SS 304-316) Kalite Paslanmaz Çelik (Cr-Ni) *Material : 304-316 Quality (SS 304-316) Stainless Steel (Cr-Ni)*



## ÇELİK DÜBELLER

## Steel Anchors

## Стальные дюбели



### Çekmeli Dübel Steel Anchor

Дюбель усадочный

Sipariş kodu Order code Код заявки	Ağırlık (Kg/ad.) Weight (Kg/unit) Вес (кг/шт)	D mm	Dübel matkap ucu çapları Ø	Price list прайс-лист шт/у.е.
GB-3-M6 E	0,020	M6	10	0,33
GB-3 E	0,040	M8	12	0,42
GB-4 E	0,077	M10	15	0,77
GB-5 E	0,113	M12	18	1,10

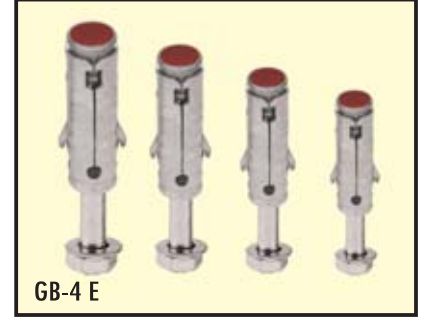

### Cıvatalı Borulu Dübel Pipe Type Steel Anchor

Дюбели винтовые трубчатого типа

Sipariş kodu Order code Код заявки	Ağırlık (Kg/ad.) Weight (Kg/unit) Вес (кг/шт)	D mm	Dübel matkap ucu çapları Ø	Price list прайс-лист шт/у.е.
GB-3-A-M6 E	0,022	M6	10	0,32
GB-3-A E	0,045	M8	13	0,45
GB-4-A E	0,076	M10	15	0,78
GB-5-A E	0,110	M12	16	0,94



### Çakmalı Dübel Non Drill Anchor

Дюбель усадочный

Sipariş kodu Order code Код заявки	Ağırlık (Kg/ad.) Weight (Kg/unit) Вес (кг/шт)	D mm	Dübel matkap ucu çapları Ø	Price list прайс-лист шт/у.е.
GB-3-B-M6 E	0,013	M6	8	0,19
GB-3-B E	0,026	M8	10	0,25
GB-4-B E	0,049	M10	12	0,48
GB-5-B E	0,091	M12	15	1,05



### Saç Gömleklİ Dübel Steel Sheet Cased Anchor

Дюбели с гильзой из листового металла

Sipariş kodu Order code Код заявки	Ağırlık (Kg/ad.) Weight (Kg/unit) Вес (кг/шт)	D mm	Dübel matkap ucu çapları Ø	Price list прайс-лист шт/у.е.
GB-3-C-M6/45 E	0,015	M6x45	8	0,15
GB-3-C-M6/65 E	0,020	M6x65	8	0,21
GB-3-C/55 E	0,029	M8x55	10	0,25
GB-3-C/75 E	0,039	M8x75	10	0,29
GB-4-C/70 E	0,060	M10x70	12	0,49
GB-4-C/85 E	0,066	M10x85	12	0,55
GB-4-C/110 E	0,086	M10x110	12	0,67
GB-5-C/90 E	0,110	M12x90	16	0,93
GB-5-C/110 E	0,129	M12x110	16	1,10





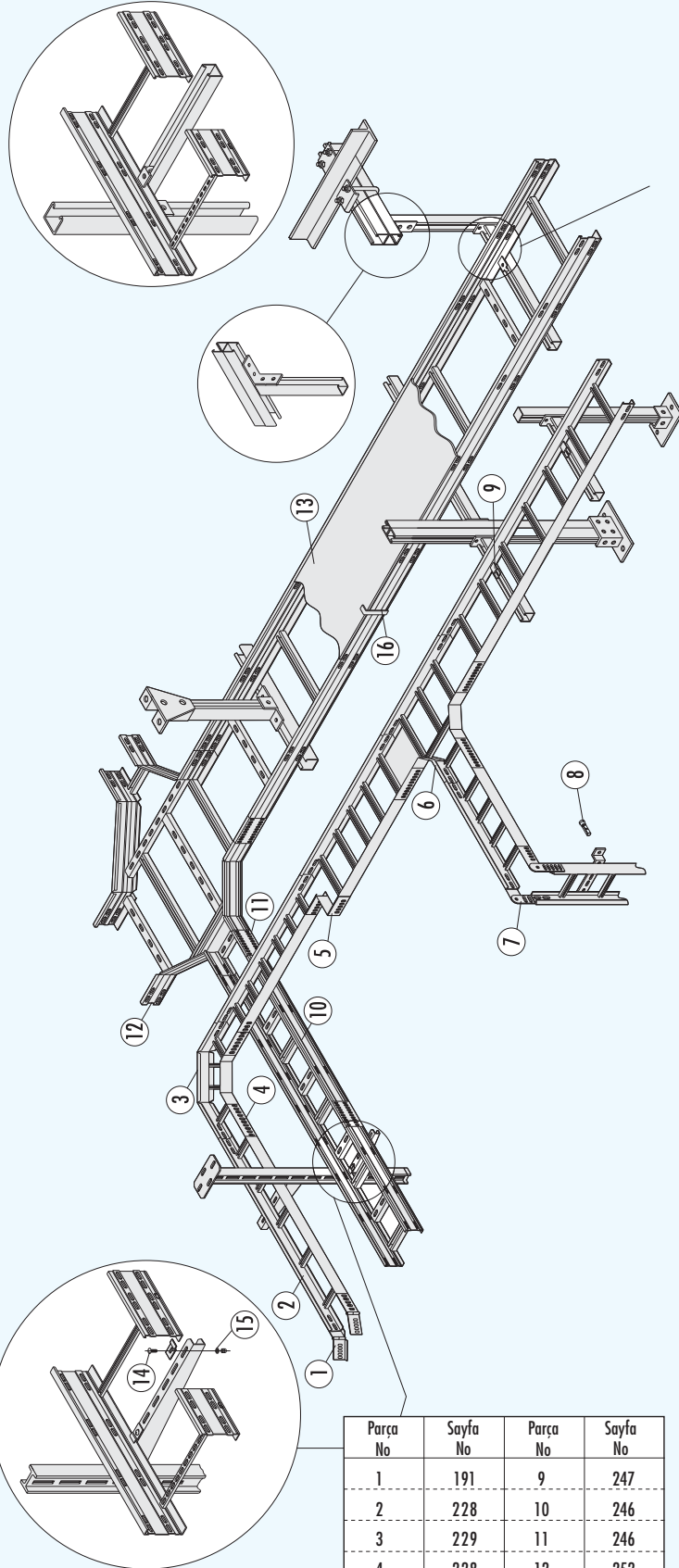

Parça No	Sayfa No	Parça No	Sayfa No
1	191	9	247
2	228	10	246
3	229	11	246
4	228	12	252
5	164	13	189
6	232	14	222
7	191	15	222
8	226	16	189

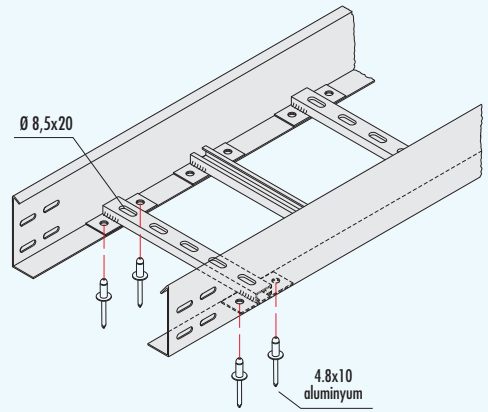
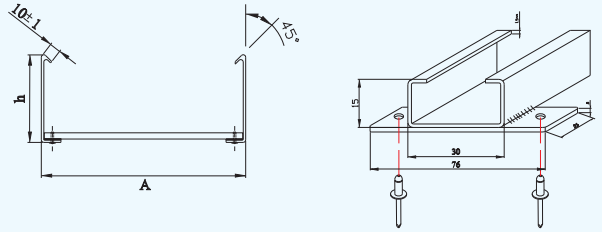
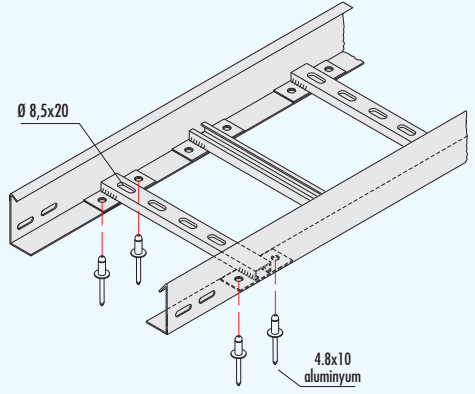
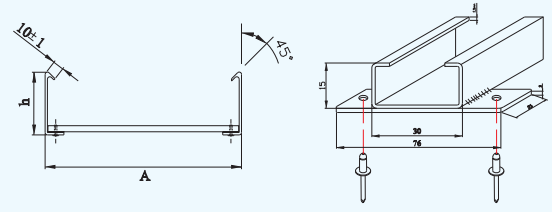

Kablo Merdivenleri Kaynaklı ve Perçinli imal edilmektedir.  
Ağırlık ve taşıma kapasitesi tüm katalog değerleri için aynıdır.

## C PROFİL BASAMAKLI KABLO MERDİVENİ

Кабельная Лестница Со Ступеньками С-профиля

## Cable Ladder With C-Profile Rung

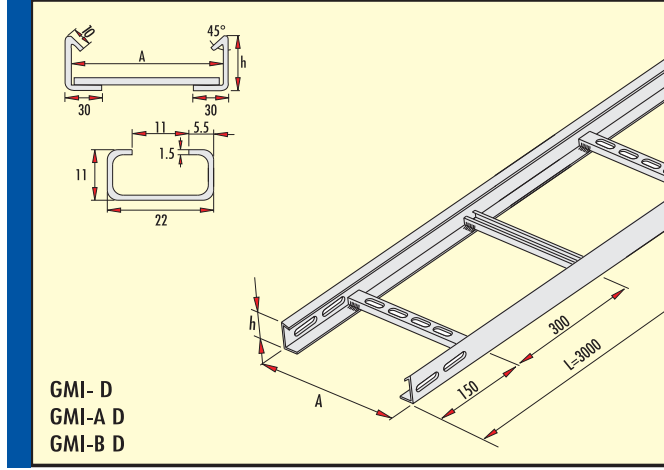

### C Profil Basamaklı Kablo Merdiveni Cable Ladder With C-Profile Rung

Кабельная Лестница Со Ступеньками С-профиля

Sipariş kodu Order code Код заявки	Ağırlık (Kg/mt.) Weight (Kg/mt) Вес (кг / м)	A mm	h mm	e mm	Price list прайс-лист М/у.е.	
					Pre-Galvanized Предв. Цинк-ия	Hot dip Galvanized гор.оцинк. HDZ
GMI-10 D	2,300	100	50	1,5	12,65	23,00
GMI-20 D	2,500	200	50	1,5	13,75	25,00
GMI-30 D	2,700	300	50	1,5	14,85	27,00
GMI-40 D	3,600	400	50	2	20,00	36,00
GMI-50 D	3,750	500	50	2	20,63	37,50
GMI-60 D	3,900	600	50	2	21,45	39,00
GMI-A10 D	2,600	100	60	1,5	14,30	26,00
GMI-A20 D	2,800	200	60	1,5	15,40	28,00
GMI-A30 D	2,950	300	60	1,5	16,23	29,50
GMI-A40 D	3,900	400	60	2	21,45	39,00
GMI-A50 D	4,100	500	60	2	22,55	41,00
GMI-A60 D	4,300	600	60	2	23,65	43,00
GMI-B10 D	4,000	100	70	2	22,00	40,00
GMI-B20 D	4,100	200	70	2	22,55	41,00
GMI-B30 D	4,200	300	70	2	23,10	42,00
GMI-B40 D	4,300	400	70	2	23,65	43,00
GMI-B50 D	4,450	500	70	2	24,50	44,50
GMI-B60 D	4,600	600	70	2	25,30	46,00

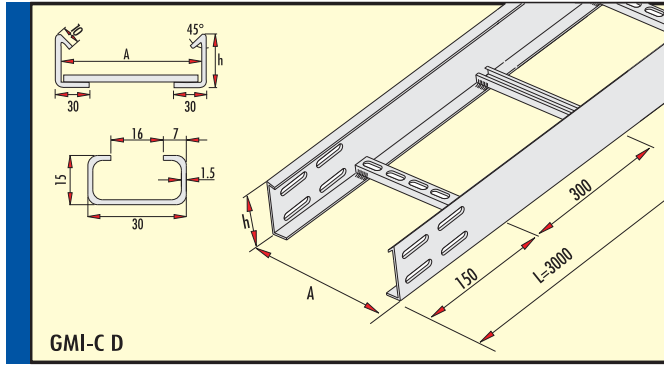

### C Profil Basamaklı Kablo Merdiveni Cable Ladder With C-Profile Rung

Кабельная Лестница Со Ступеньками С-профиля

Sipariş kodu Order code Код заявки	Ağırlık (Kg/mt.) Weight (Kg/mt) Вес (кг / м)	A mm	h mm	e mm	Price list прайс-лист М/у.е.	
					Pre-Galvanized Предв. Цинк-ия	Hot dip Galvanized гор.оцинк. HDZ
GMI-C20 D	4,900	200	100	2	27,00	49,00
GMI-C30 D	5,100	300	100	2	28,00	51,00
GMI-C40 D	5,400	400	100	2	30,00	54,00
GMI-C50 D	5,700	500	100	2	31,35	57,00
GMI-C60 D	5,950	600	100	2	32,72	60,00

## EK PARÇASI

## Joining Piece

Соединительные элементы

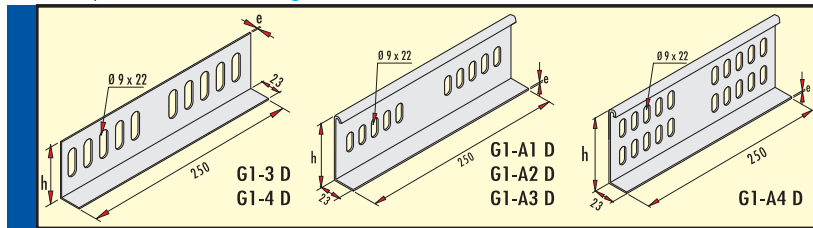

### Ek Parçası Joining Piece

Соединительные элементы

Sipariş kodu Order code Код заявки	Ağırlık (Kg/ad.) Weight (Kg/unit) Вес (кг / шт)	h mm	e mm	Price list прайс-лист шт/у.е.	
				Pre-Galvanized Предв. Цинк-ия	Hot dip Galvanized гор.оцинк. HDZ
G1-3 D	0,240	50	2	2,40	3,36
G1-4 D	0,270	60	2	2,70	3,78
G1-5 D	0,420	100	2	4,20	5,88
G1-A1 D	0,300	54	2	3,00	4,20
G1-A2 D	0,330	64	2	3,30	4,62
G1-A3 D	0,350	74	2	3,50	4,90
G1-A4 D	0,560	104	2	5,60	7,84

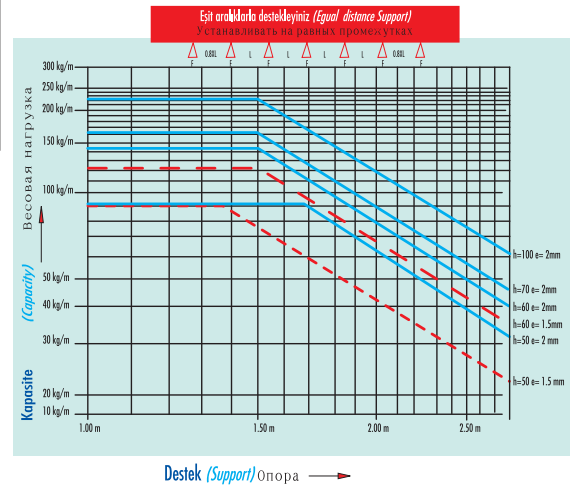

Kaplama : TS 914 EN ISO-1461 (BS-EN-ISO-1461) Sıcak Daldırma Galvaniz. Coating : TS 914 EN ISO-1461 (BS-EN-ISO-1461) Hot Dip Galvanized

Talep üzerine tüm ürünler RODINA 50® malzemesi ile kaplanarak (max) 400°C ısıya, asit, tuz ve kum etkilerine karşı mukavemet sağlar.

In case of required all type of materials can be coated with RODINA 50® which will give an extra resistant at effect of 400°C heat, acid, salt and sand for the material.

90° DÖNÜŞ ELEMANLARI  
угловые элементы 90°

90° Flat Bends

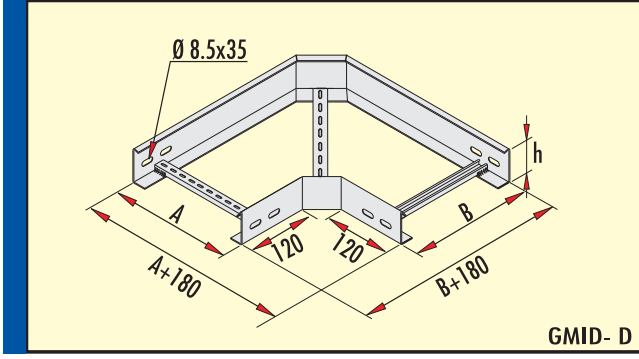

Sipariş kodu Order code Код заявки	Ağırlık (Kg/ad.) Weight (Kg/unit) Вес (кг/шт)	A mm	B mm	h mm	e mm	Price list прайс-лист шт /у.е.	
						Pre-Galvanized Предв. Цинк-ия	Hot dip Galvanized гор.оцинк. HDZ
						GMID-10 D	1,300
GMID-20 D	1,900	200	200	50	2	19,00	26,60
GMID-30 D	2,500	300	300	50	2	25,00	35,00
GMID-40 D	3,100	400	400	50	2	31,00	43,40
GMID-50 D	3,700	500	500	50	2	37,00	51,80
GMID-60 D	4,300	600	600	50	2	43,00	60,20
GMID-A10 D	1,600	100	100	60	2	16,00	22,40
GMID-A20 D	2,100	200	200	60	2	21,00	29,40
GMID-A30 D	2,700	300	300	60	2	27,00	37,80
GMID-A40 D	3,300	400	400	60	2	33,00	46,20
GMID-A50 D	3,900	500	500	60	2	39,00	54,60
GMID-A60 D	4,500	600	600	60	2	45,00	63,00
GMID-B10 D	1,700	100	100	70	2	17,00	23,80
GMID-B20 D	2,300	200	200	70	2	23,00	32,20
GMID-B30 D	2,900	300	300	70	2	29,00	40,60
GMID-B40 D	3,500	400	400	70	2	35,00	49,00
GMID-B50 D	4,100	500	500	70	2	41,00	57,40
GMID-B60 D	4,600	600	600	70	2	46,00	64,40

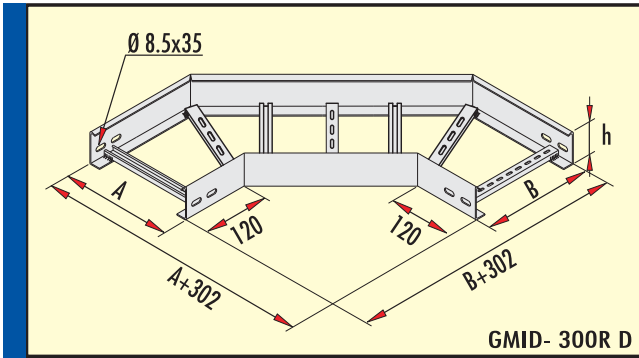

Sipariş kodu Order code Код заявки	Ağırlık (Kg/ad.) Weight (Kg/unit) Вес (кг/шт)	A mm	B mm	h mm	e mm	Price list прайс-лист шт /у.е.	
						Pre-Galvanized Предв. Цинк-ия	Hot dip Galvanized гор.оцинк. HDZ
						GMID-10 300R D	1,950
GMID-20 300R D	2,450	200	200	50	2	24,50	34,30
GMID-30 300R D	3,050	300	300	50	2	30,50	42,70
GMID-40 300R D	3,650	400	400	50	2	36,50	51,10
GMID-50 300R D	4,250	500	500	50	2	42,50	59,50
GMID-60 300R D	4,850	600	600	50	2	48,50	67,90
GMID-A10 300R D	2,050	100	100	60	2	20,50	28,70
GMID-A20 300R D	2,550	200	200	60	2	25,50	35,70
GMID-A30 300R D	3,100	300	300	60	2	31,00	43,40
GMID-A40 300R D	3,700	400	400	60	2	37,00	51,80
GMID-A50 300R D	4,300	500	500	60	2	43,00	60,20
GMID-A60 300R D	4,900	600	600	60	2	49,00	68,60
GMID-B10 300R D	2,100	100	100	70	2	21,00	29,40
GMID-B20 300R D	2,700	200	200	70	2	27,00	37,80
GMID-B30 300R D	3,300	300	300	70	2	33,00	46,20
GMID-B40 300R D	3,900	400	400	70	2	39,00	54,60
GMID-B50 300R D	4,500	500	500	70	2	45,00	63,00
GMID-B60 300R D	5,100	600	600	70	2	51,00	71,40

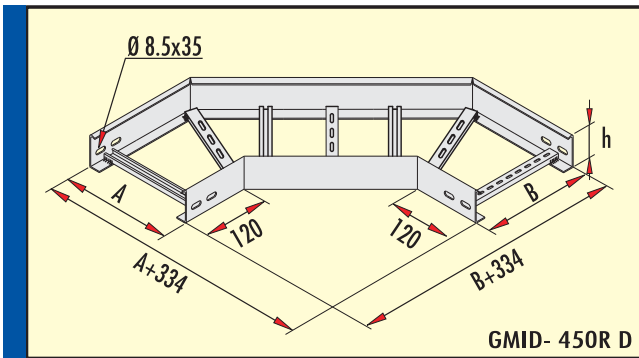

Sipariş kodu Order code Код заявки	Ağırlık (Kg/ad.) Weight (Kg/unit) Вес (кг/шт)	A mm	B mm	h mm	e mm	Price list прайс-лист шт /у.е.	
						Pre-Galvanized Предв. Цинк-ия	Hot dip Galvanized гор.оцинк. HDZ
						GMID-10 450R D	2,050
GMID-20 450R D	2,650	200	200	50	2	26,50	37,10
GMID-30 450R D	3,250	300	300	50	2	32,50	45,50
GMID-40 450R D	3,850	400	400	50	2	38,50	53,90
GMID-50 450R D	4,450	500	500	50	2	44,50	62,30
GMID-60 450R D	5,050	600	600	50	2	50,50	70,70
GMID-A10 450R D	2,150	100	100	60	2	21,50	30,10
GMID-A20 450R D	2,750	200	200	60	2	27,50	38,50
GMID-A30 450R D	3,350	300	300	60	2	33,50	46,90
GMID-A40 450R D	3,950	400	400	60	2	39,50	55,30
GMID-A50 450R D	4,550	500	500	60	2	45,50	63,70
GMID-A60 450R D	5,150	600	600	60	2	51,50	72,10
GMID-B10 450R D	2,350	100	100	70	2	23,50	32,90
GMID-B20 450R D	2,950	200	200	70	2	29,50	41,30
GMID-B30 450R D	3,550	300	300	70	2	35,50	49,70
GMID-B40 450R D	4,150	400	400	70	2	41,50	58,10
GMID-B50 450R D	4,750	500	500	70	2	47,50	66,50
GMID-B60 450R D	5,350	600	600	70	2	53,50	74,90

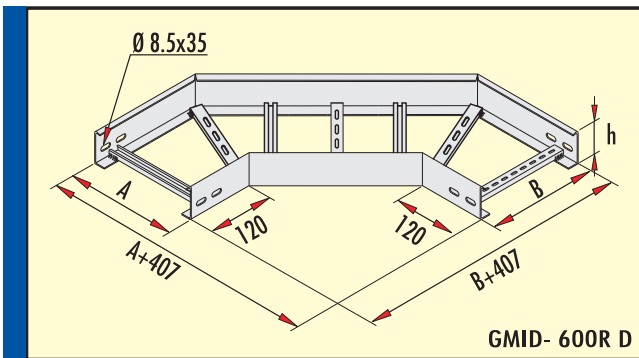

Sipariş kodu Order code Код заявки	Ağırlık (Kg/ad.) Weight (Kg/unit) Вес (кг/шт)	A mm	B mm	h mm	e mm	Price list прайс-лист шт /у.е.	
						Pre-Galvanized Предв. Цинк-ия	Hot dip Galvanized гор.оцинк. HDZ
						GMID-10 600R D	2,200
GMID-20 600R D	2,800	200	200	50	2	28,00	39,20
GMID-30 600R D	3,400	300	300	50	2	34,00	47,60
GMID-40 600R D	4,000	400	400	50	2	40,00	56,00
GMID-50 600R D	4,600	500	500	50	2	46,00	64,40
GMID-60 600R D	5,200	600	600	50	2	52,00	72,80
GMID-A10 600R D	2,300	100	100	60	2	23,00	32,20
GMID-A20 600R D	2,900	200	200	60	2	29,00	40,60
GMID-A30 600R D	3,500	300	300	60	2	35,00	49,00
GMID-A40 600R D	4,100	400	400	60	2	41,00	57,40
GMID-A50 600R D	4,700	500	500	60	2	47,00	65,80
GMID-A60 600R D	5,300	600	600	60	2	53,00	74,20
GMID-B10 600R D	2,550	100	100	70	2	25,50	35,70
GMID-B20 600R D	3,150	200	200	70	2	31,50	44,10
GMID-B30 600R D	3,750	300	300	70	2	37,50	52,50
GMID-B40 600R D	4,350	400	400	70	2	43,50	60,90
GMID-B50 600R D	4,950	500	500	70	2	49,50	69,30
GMID-B60 600R D	5,550	600	600	70	2	55,50	77,70

Kaplama : TS 914 EN ISO-1461 (BS-EN-ISO-1461) Sıcak Daldırma Galvaniz. Coating : TS 914 EN ISO-1461 (BS-EN-ISO-1461) Hot Dip Galvanized

Talep üzerine tüm ürünler RODINA 50® malzemesi ile kaplanarak (max) 400°C ısıya, asit, tuz ve kum etkilerine karşı mukavemet sağlar.

In case of required all type of materials can be coated with RODINA 50® which will give on extra resistant at effect of 400°C heat, acid, salt and sand for the material.

90° DÖNÜŞ ELEMANLARI

90° Flat Bends

угловые элементы 90°

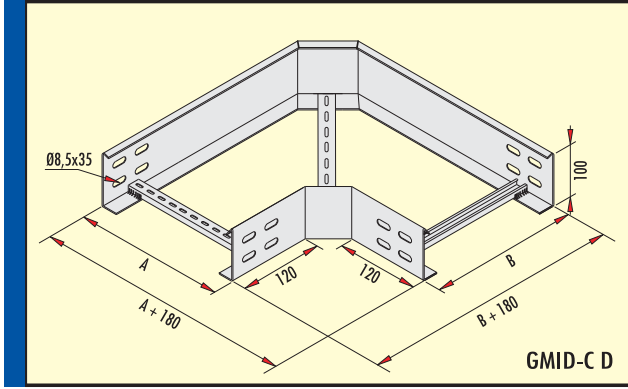

90° Dönüş Elemanı (h=100 mm)

90° Flat Bend (h=100 mm)

угловые элементы 90°

Sipariş kodu Order code Код заявки	Ağırlık (Kg/ad.) Weight (Kg/unit) Вес (кг/шт)	A mm	B mm	e mm	Price list прайс-лист шт/у.е.	
					Pre-Galvanized Предв. Цинк-ия	Hot dip Galvanized гор.оцинк. HDZ
GMID-C20 D	3,100	200	200	2	31,00	43,40
GMID-C30 D	3,550	300	300	2	35,50	49,70
GMID-C40 D	4,000	400	400	2	40,00	56,00
GMID-C50 D	4,400	500	500	2	44,00	61,60
GMID-C60 D	4,850	600	600	2	48,50	67,90

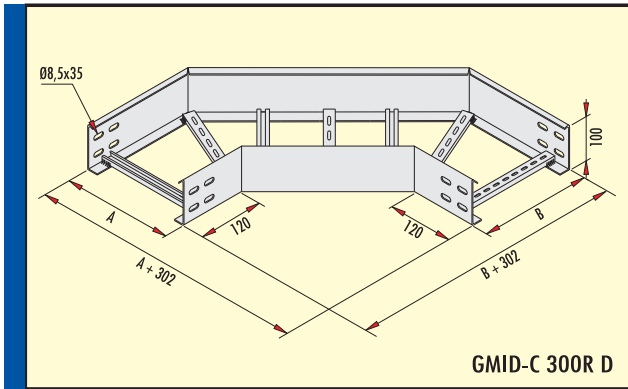

90° Dönüş Elemanı 300 Radyüs (h=100 mm)

90° Flat Bend Radius 300 (h=100 mm)

угловые элементы 90°

Sipariş kodu Order code Код заявки	Ağırlık (Kg/ad.) Weight (Kg/unit) Вес (кг/шт)	A mm	B mm	e mm	Price list прайс-лист шт/у.е.	
					Pre-Galvanized Предв. Цинк-ия	Hot dip Galvanized гор.оцинк. HDZ
GMID-C20 300R D	3,250	200	200	2	32,50	45,50
GMID-C30 300R D	4,000	300	300	2	40,00	56,00
GMID-C40 300R D	4,700	400	400	2	47,00	65,80
GMID-C50 300R D	5,450	500	500	2	54,50	76,30
GMID-C60 300R D	6,200	600	600	2	62,00	86,80

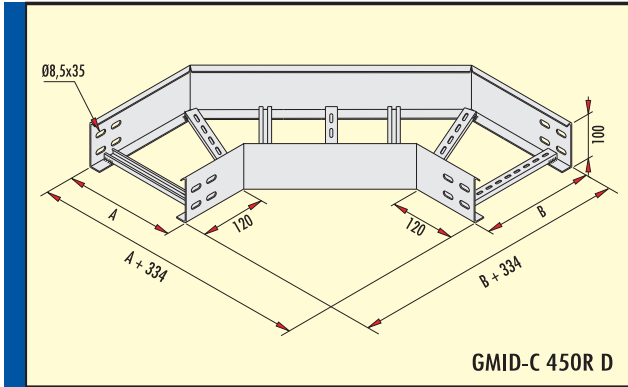

90° Dönüş Elemanı 450 Radyüs (h=100 mm)

90° Flat Bend Radius 450 (h=100 mm)

угловые элементы 90°

Sipariş kodu Order code Код заявки	Ağırlık (Kg/ad.) Weight (Kg/unit) Вес (кг/шт)	A mm	B mm	e mm	Price list прайс-лист шт/у.е.	
					Pre-Galvanized Предв. Цинк-ия	Hot dip Galvanized гор.оцинк. HDZ
GMID-C20 450R D	3,500	200	200	2	35,00	49,00
GMID-C30 450R D	4,300	300	300	2	43,00	60,20
GMID-C40 450R D	5,000	400	400	2	50,00	70,00
GMID-C50 450R D	5,750	500	500	2	57,50	80,50
GMID-C60 450R D	6,500	600	600	2	65,00	91,00

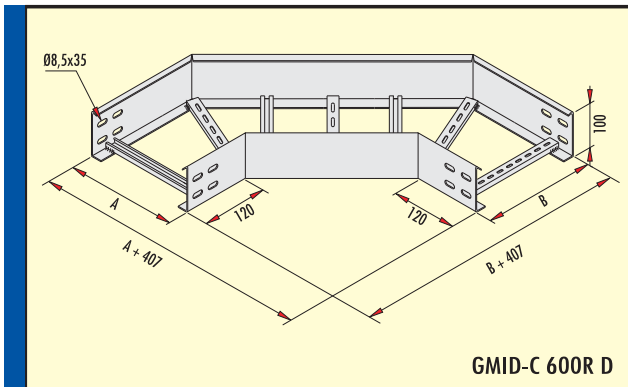

90° Dönüş Elemanı 600 Radyüs (h=100 mm)

90° Flat Bend Radius 600 (h=100 mm)

угловые элементы 90° (Радиус 600)

Sipariş kodu Order code Код заявки	Ağırlık (Kg/ad.) Weight (Kg/unit) Вес (кг/шт)	A mm	B mm	e mm	Price list прайс-лист шт/у.е.	
					Pre-Galvanized Предв. Цинк-ия	Hot dip Galvanized гор.оцинк. HDZ
GMID-C20 600R D	3,750	200	200	2	37,50	52,50
GMID-C30 600R D	4,500	300	300	2	45,00	63,00
GMID-C40 600R D	5,250	400	400	2	52,50	73,50
GMID-C50 600R D	6,000	500	500	2	60,00	84,00
GMID-C60 600R D	6,750	600	600	2	67,50	94,50

Kaplama : TS 914 EN ISO-1461 (BS-EN-ISO-1461) Sıcak Daldırma Galvaniz. Coating : TS 914 EN ISO-1461 (BS-EN-ISO-1461) Hot Dip Galvanized

Talep üzerine tüm ürünler RODINA 50® malzemesi ile kaplanarak (max) 400°C ısıya, asit, tuz ve kum etkilerine karşı mukavemet sağlar.

In case of required all type of materials can be coated with RODINA 50® which will give on extra resistant at effect of 400°C heat, acid, salt and sand for the material.



90° DÖNÜŞ ELEMANI KAPAKLARI

90° Flat Bend Covers

90° Плоских Покрытий Изгиба

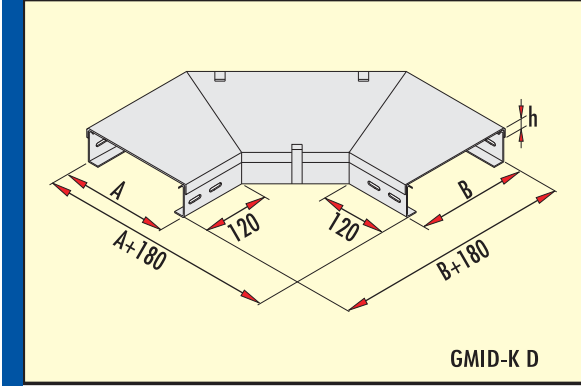

90° Dönüş Eleman Kapağı

90° Flat Bend Cover

90° Плоских Покрытий Изгиба

Sipariş kodu Order code Код заявки	Ağırlık (Kg/ad.) Weight (Kg/unit) Вес (кг / шт)	A mm	B mm	e mm	h mm	Price list прайс-лист шт / у.е.	
						Pre-Galvanized Предв. Цинк-ия	Hot dip Galvanized гор.оцинк. HDZ
GMID-10K D	0.500	100	100	1	9	5,00	7,00
GMID-20K D	0.800	200	200	1	9	8,00	11,20
GMID-30K D	1.400	300	300	1	9	14,00	19,60
GMID-40K D	3.500	400	400	1.5	9	35,00	49,00
GMID-50K D	4.650	500	500	1.5	9	46,50	65,10
GMID-60K D	6.450	600	600	1.5	9	64,50	90,30

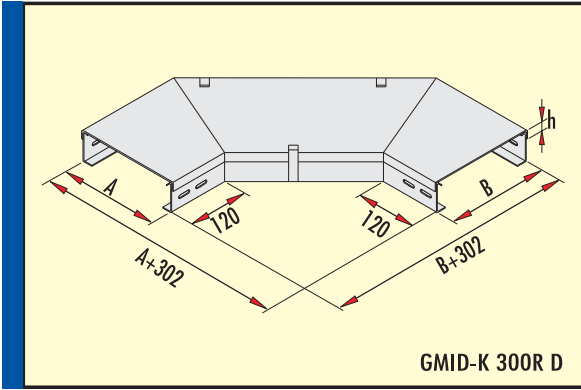

90° Dönüş Eleman Kapağı 300 Radüs

90° Flat Bend Cover Radius 300

90° Плоских Радиусов Покрытия Изгиба 300

Sipariş kodu Order code Код заявки	Ağırlık (Kg/ad.) Weight (Kg/unit) Вес (кг / шт)	A mm	B mm	e mm	h mm	Price list прайс-лист шт / у.е.	
						Pre-Galvanized Предв. Цинк-ия	Hot dip Galvanized гор.оцинк. HDZ
GMID-10K 300R D	1,000	100	100	1	9	10,00	14,00
GMID-20K 300R D	1,400	200	200	1	9	14,00	19,60
GMID-30K 300R D	2,400	300	300	1	9	24,00	33,60
GMID-40K 300R D	5,400	400	400	1.5	9	54,00	75,60
GMID-50K 300R D	7,500	500	500	1.5	9	75,00	105,00
GMID-60K 300R D	10,100	600	600	1.5	9	101,00	141,40

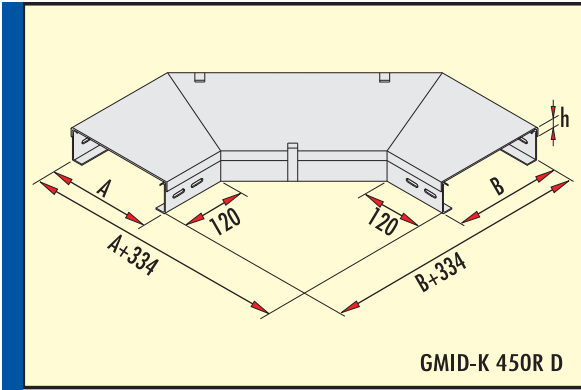

90° Dönüş Eleman Kapağı 450 Radüs

90° Flat Bend Cover Radius 450

90° Плоских Радиусов Покрытия Изгиба 450

Sipariş kodu Order code Код заявки	Ağırlık (Kg/ad.) Weight (Kg/unit) Вес (кг / шт)	A mm	B mm	e mm	h mm	Price list прайс-лист шт / у.е.	
						Pre-Galvanized Предв. Цинк-ия	Hot dip Galvanized гор.оцинк. HDZ
GMID-10K 450R D	1,100	100	100	1	9	11,00	15,40
GMID-20K 450R D	1,500	200	200	1	9	15,00	21,00
GMID-30K 450R D	2,500	300	300	1	9	25,00	35,00
GMID-40K 450R D	5,500	400	400	1.5	9	55,00	77,00
GMID-50K 450R D	7,600	500	500	1.5	9	76,00	106,40
GMID-60K 450R D	10,200	600	600	1.5	9	102,00	142,80

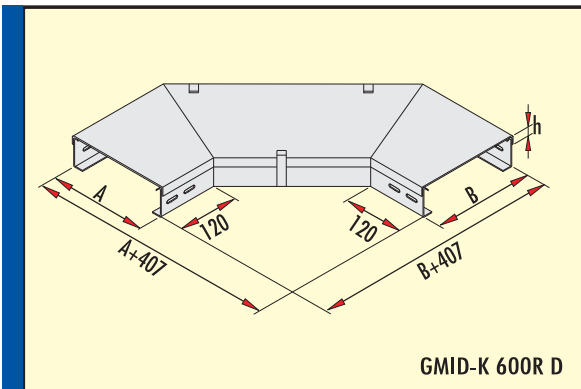

90° Dönüş Eleman Kapağı 600 Radüs

90° Flat Bend Cover Radius 600

90° Плоских Радиусов Покрытия Изгиба 600

Sipariş kodu Order code Код заявки	Ağırlık (Kg/ad.) Weight (Kg/unit) Вес (кг / шт)	A mm	B mm	e mm	h mm	Price list прайс-лист шт / у.е.	
						Pre-Galvanized Предв. Цинк-ия	Hot dip Galvanized гор.оцинк. HDZ
GMID-10K 600R D	1,200	100	100	1	9	12,00	16,80
GMID-20K 600R D	1,600	200	200	1	9	16,00	22,40
GMID-30K 600R D	2,700	300	300	1	9	27,00	37,80
GMID-40K 600R D	5,850	400	400	1.5	9	58,50	81,90
GMID-50K 600R D	8,050	500	500	1.5	9	80,50	112,70
GMID-60K 600R D	10,850	600	600	1.5	9	108,50	151,90

Kaplama : TS 914 EN ISO-1461 (BS-EN-ISO-1461) Sıcak Daldırma Galvaniz. Coating : TS 914 EN ISO-1461 (BS-EN-ISO-1461) Hot Dip Galvanized

Talep üzerine tüm ürünler RODINA 50® malzemesi ile kaplanarak (max) 400°C ısıya, asit, tuz ve kum etkilerine karşı mukavemet sağlar.

In case of required all type of materials can be coated with RODINA 50® which will give on extra resistant at effect of 400°C heat, acid, salt and sand for the material.

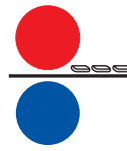

"T" BAĞLANTI ELEMANLARI Tee "T" Elements

«Т» образные соединительные элементы

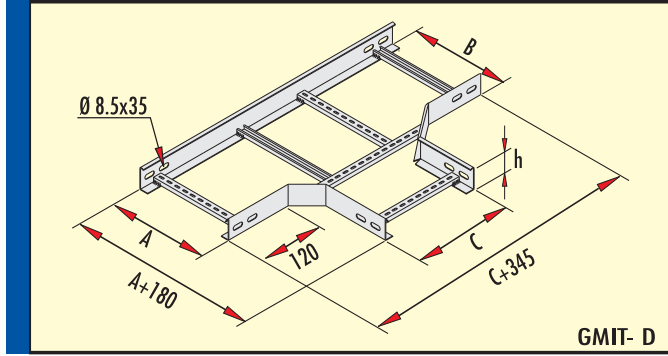

GMIT- D

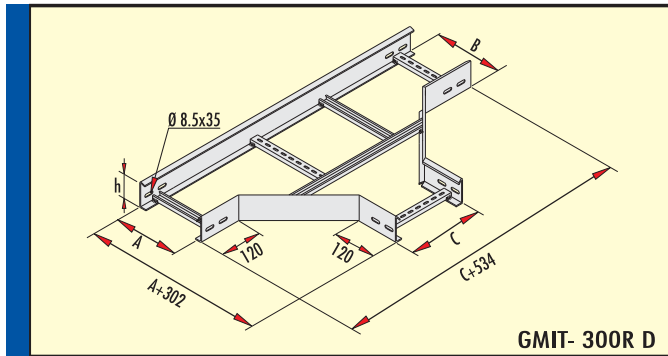

GMIT- 300R D

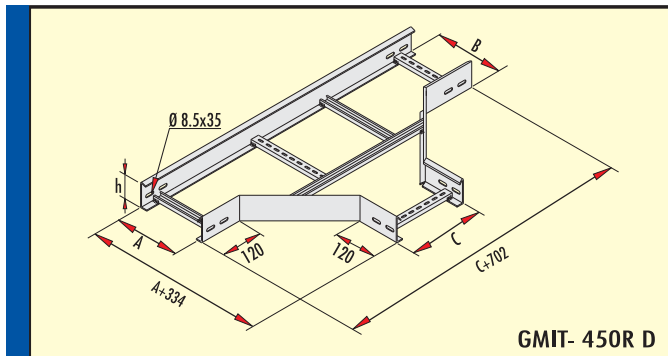

GMIT- 450R D

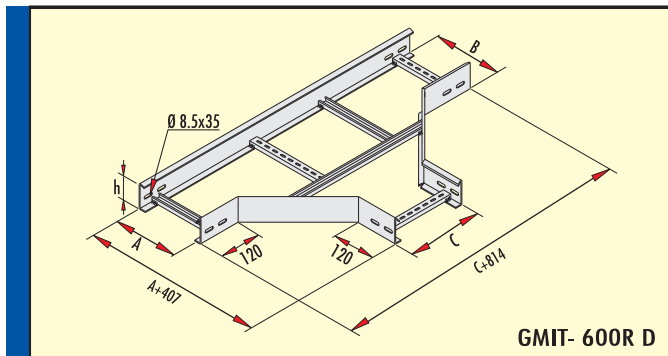

GMIT- 600R D

Sipariş kodu Order code Код заявки	Ağırlık (Kg/ad.) Weight (Kg/unit) Вес (кг /шт)	A-B-C mm	h mm	e mm	Price list прайс-лист шт./у.е.	
					Pre-Galvanized Предв. Цинк-ия	Hot dip Galvanized гор.оцинк. HDZ
					«Т» образные соединительные элементы	
GMIT-10 D	2,100	100	50	2	21,00	29,40
GMIT-20 D	2,500	200	50	2	25,00	35,00
GMIT-30 D	2,900	300	50	2	29,00	40,60
GMIT-40 D	3,400	400	50	2	34,00	47,60
GMIT-50 D	3,850	500	50	2	38,50	53,90
GMIT-60 D	4,250	600	50	2	42,50	59,50
GMIT-A10 D	2,150	100	60	2	21,50	30,10
GMIT-A20 D	2,650	200	60	2	26,50	37,10
GMIT-A30 D	3,100	300	60	2	31,00	43,40
GMIT-A40 D	3,550	400	60	2	35,50	49,70
GMIT-A50 D	4,000	500	60	2	40,00	56,00
GMIT-A60 D	4,450	600	60	2	44,50	62,30
GMIT-B10 D	2,400	100	70	2	24,00	33,60
GMIT-B20 D	2,900	200	70	2	29,00	40,60
GMIT-B30 D	3,100	300	70	2	31,00	43,40
GMIT-B40 D	3,350	400	70	2	33,50	46,90
GMIT-B50 D	3,800	500	70	2	38,00	53,20
GMIT-B60 D	4,750	600	70	2	47,50	66,50

Sipariş kodu Order code Код заявки	Ağırlık (Kg/ad.) Weight (Kg/unit) Вес (кг /шт)	A-B-C mm	h mm	e mm	Price list прайс-лист шт./у.е.	
					Pre-Galvanized Предв. Цинк-ия	Hot dip Galvanized гор.оцинк. HDZ
					«Т» образные соединительные элементы (Радиус 300)	
GMIT-10 300R D	3,100	100	50	2	31,00	43,40
GMIT-20 300R D	3,200	200	50	2	32,00	44,80
GMIT-30 300R D	3,350	300	50	2	33,50	46,90
GMIT-40 300R D	3,700	400	50	2	37,00	51,80
GMIT-50 300R D	4,150	500	50	2	41,50	58,10
GMIT-60 300R D	4,500	600	50	2	45,00	63,00
GMIT-A10 300R D	2,900	100	60	2	29,00	40,60
GMIT-A20 300R D	3,300	200	60	2	33,00	46,20
GMIT-A30 300R D	3,750	300	60	2	37,50	52,50
GMIT-A40 300R D	4,200	400	60	2	42,00	58,80
GMIT-A50 300R D	4,650	500	60	2	46,50	65,10
GMIT-A60 300R D	5,050	600	60	2	50,50	70,70
GMIT-B10 300R D	3,200	100	70	2	32,00	44,80
GMIT-B20 300R D	3,650	200	70	2	36,50	51,10
GMIT-B30 300R D	4,150	300	70	2	41,50	58,10
GMIT-B40 300R D	4,600	400	70	2	46,00	64,40
GMIT-B50 300R D	5,100	500	70	2	51,00	71,40
GMIT-B60 300R D	5,500	600	70	2	55,00	77,00

Sipariş kodu Order code Код заявки	Ağırlık (Kg/ad.) Weight (Kg/unit) Вес (кг /шт)	A-B-C mm	h mm	e mm	Price list прайс-лист шт./у.е.	
					Pre-Galvanized Предв. Цинк-ия	Hot dip Galvanized гор.оцинк. HDZ
					«Т» образные соединительные элементы (Радиус 450)	
GMIT-10 450R D	3,400	100	50	2	34,00	47,60
GMIT-20 450R D	3,800	200	50	2	38,00	53,20
GMIT-30 450R D	4,250	300	50	2	42,50	59,50
GMIT-40 450R D	4,650	400	50	2	46,50	65,10
GMIT-50 450R D	5,150	500	50	2	51,50	72,10
GMIT-60 450R D	5,500	600	50	2	55,00	77,00
GMIT-A10 450R D	3,000	100	60	2	30,00	42,00
GMIT-A20 450R D	3,900	200	60	2	39,00	54,60
GMIT-A30 450R D	4,350	300	60	2	43,50	60,90
GMIT-A40 450R D	4,800	400	60	2	48,00	67,20
GMIT-A50 450R D	5,250	500	60	2	52,50	73,50
GMIT-A60 450R D	5,650	600	60	2	56,50	79,10
GMIT-B10 450R D	4,000	100	70	2	40,00	56,00
GMIT-B20 450R D	4,400	200	70	2	44,00	61,60
GMIT-B30 450R D	4,850	300	70	2	48,50	67,90
GMIT-B40 450R D	5,300	400	70	2	53,00	74,20
GMIT-B50 450R D	5,800	500	70	2	58,00	81,20
GMIT-B60 450R D	6,200	600	70	2	62,00	86,80

Sipariş kodu Order code Код заявки	Ağırlık (Kg/ad.) Weight (Kg/unit) Вес (кг /шт)	A-B-C mm	h mm	e mm	Price list прайс-лист шт./у.е.	
					Pre-Galvanized Предв. Цинк-ия	Hot dip Galvanized гор.оцинк. HDZ
					«Т» образные соединительные элементы (Радиус 600)	
GMIT-10 600R D	3,900	100	50	2	39,00	54,60
GMIT-20 600R D	4,300	200	50	2	43,00	60,20
GMIT-30 600R D	4,750	300	50	2	47,50	66,50
GMIT-40 600R D	5,200	400	50	2	52,00	72,80
GMIT-50 600R D	5,650	500	50	2	56,50	79,10
GMIT-60 600R D	6,050	600	50	2	60,50	84,70
GMIT-A10 600R D	4,000	100	60	2	40,00	56,00
GMIT-A20 600R D	4,450	200	60	2	44,50	62,30
GMIT-A30 600R D	4,900	300	60	2	49,00	68,60
GMIT-A40 600R D	5,350	400	60	2	53,50	74,90
GMIT-A50 600R D	5,850	500	60	2	58,50	81,90
GMIT-A60 600R D	6,200	600	60	2	62,00	86,80
GMIT-B10 600R D	4,500	100	70	2	45,00	63,00
GMIT-B20 600R D	5,000	200	70	2	50,00	70,00
GMIT-B30 600R D	5,450	300	70	2	54,50	76,30
GMIT-B40 600R D	5,900	400	70	2	59,00	82,60
GMIT-B50 600R D	6,400	500	70	2	64,00	89,60
GMIT-B60 600R D	6,850	600	70	2	68,50	95,90

Kaplama : TS 914 EN ISO-1461 (BS-EN-ISO-1461) Sıcak Daldırma Galvaniz. Coating : TS 914 EN ISO-1461 (BS-EN-ISO-1461) Hot Dip Galvanized

Talep üzerine tüm ürünler RODINA 50® malzemesi ile kaplanarak (max) 400°C ısıya, asit, tuz ve kum etkilerine karşı mukavemet sağlar.

In case of required all type of materials can be coated with RODINA 50® which will give on extra resistant at effect of 400°C heat, acid, salt and sand for the material.

“T” BAĞLANTI ELEMANLARI

Tee “T” Elements

«T» образные соединительные элементы

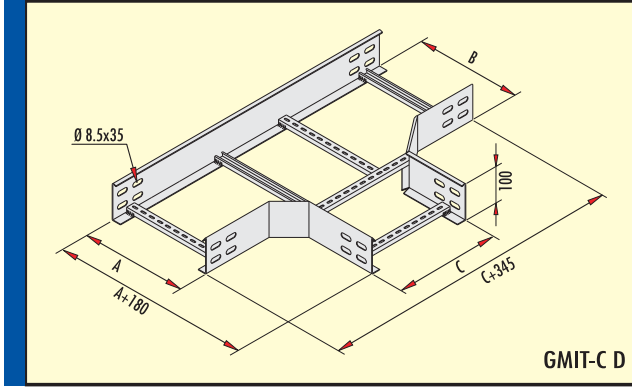

GMIT-C D

“T” Bağlantı Elemanı (h=100 mm)

Tee “T” Element (h=100 mm)

«T» образные соединительные элементы

Sipariş kodu Order code Код заявки	Ağırlık (Kg/ad.) Weight (Kg/unit) Вес (кг /шт)	A-B-C mm	e mm	Price list прайс-лист шт/у.е.	
				Pre-Galvanized Предв. Цинк-ия	Hot dip Galvanized гор.оцинк. HDZ
GMIT-C20 D	3,450	200	2	34,50	48,30
GMIT-C30 D	4,000	300	2	40,00	56,00
GMIT-C40 D	4,450	400	2	44,50	62,30
GMIT-C50 D	5,000	500	2	50,00	70,00
GMIT-C60 D	5,450	600	2	54,50	76,30

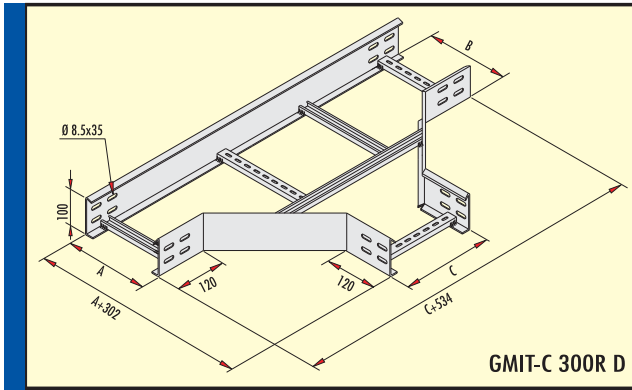

GMIT-C 300R D

“T” Bağlantı Elemanı 300 Radius (h=100 mm)

Tee “T” Element Radius 300 (h=100 mm)

угловые элементы 90° (Радиус 300)

Sipariş kodu Order code Код заявки	Ağırlık (Kg/ad.) Weight (Kg/unit) Вес (кг /шт)	A-B-C mm	e mm	Price list прайс-лист шт/у.е.	
				Pre-Galvanized Предв. Цинк-ия	Hot dip Galvanized гор.оцинк. HDZ
GMIT-C20 300R D	4,300	200	2	43,00	60,20
GMIT-C30 300R D	4,850	300	2	48,50	67,90
GMIT-C40 300R D	5,300	400	2	53,00	74,20
GMIT-C50 300R D	5,850	500	2	58,50	81,90
GMIT-C60 300R D	6,300	600	2	63,00	88,20

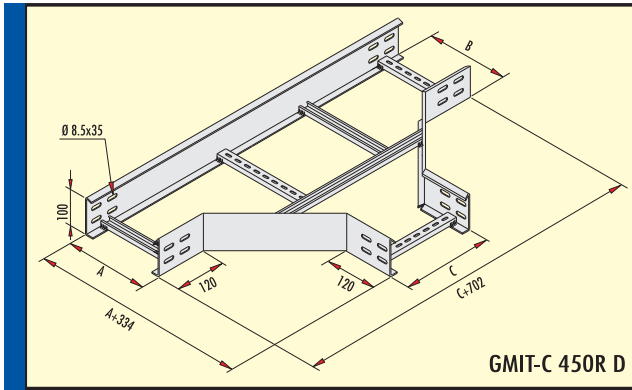

GMIT-C 450R D

“T” Bağlantı Elemanı 450 Radius (h=100 mm)

Tee “T” Element Radius 450 (h=100 mm)

угловые элементы 90° (Радиус 450)

Sipariş kodu Order code Код заявки	Ağırlık (Kg/ad.) Weight (Kg/unit) Вес (кг /шт)	A-B-C mm	e mm	Price list прайс-лист шт/у.е.	
				Pre-Galvanized Предв. Цинк-ия	Hot dip Galvanized гор.оцинк. HDZ
GMIT-C20 450R D	5,150	200	2	51,50	72,10
GMIT-C30 450R D	5,650	300	2	56,50	79,10
GMIT-C40 450R D	6,150	400	2	61,50	86,10
GMIT-C50 450R D	6,700	500	2	67,00	93,80
GMIT-C60 450R D	7,150	600	2	71,50	100,10

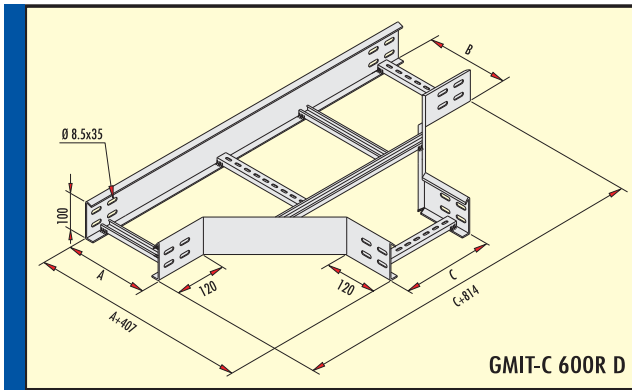

GMIT-C 600R D

“T” Bağlantı Elemanı 600 Radius (h=100 mm)

Tee “T” Element Radius 600 (h=100 mm)

угловые элементы 90° (Радиус 600)

Sipariş kodu Order code Код заявки	Ağırlık (Kg/ad.) Weight (Kg/unit) Вес (кг /шт)	A-B-C mm	e mm	Price list прайс-лист шт/у.е.	
				Pre-Galvanized Предв. Цинк-ия	Hot dip Galvanized гор.оцинк. HDZ
GMIT-C20 600R D	5,900	200	2	59,00	82,60
GMIT-C30 600R D	6,450	300	2	64,50	90,30
GMIT-C40 600R D	6,900	400	2	69,00	96,60
GMIT-C50 600R D	7,450	500	2	74,50	104,30
GMIT-C60 600R D	7,900	600	2	79,00	110,60

Kaplama : TS 914 EN ISO-1461 (BS-EN-ISO-1461) Sıcak Daldırma Galvaniz. Coating : TS 914 EN ISO-1461 (BS-EN-ISO-1461) Hot Dip Galvanized

Talep üzerine tüm ürünler RODINA 50® malzemesi ile kaplanarak (max) 400°C ısıya, asit, tuz ve kum etkilerine karşı mukavemet sağlar.

In case of required all type of materials can be coated with RODINA 50® which will give on extra resistant at effect of 400°C heat, acid, salt and sand for the material.

"T" BAĞLANTI ELEMANI KAPAKLARI

Tee "T" Element Covers

Мишень "Т" Покрyтия Элемента

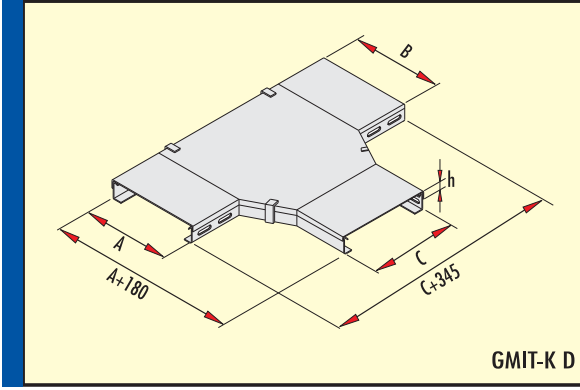

"T" Bağlantı Eleman Kapağı

Tee "T" Element Cover

Мишень "Т" Покрyтия Элемента

Sipariş kodu Order code Код заявки	Ağırlık (Kg/ad.) Weight (Kg/unit) Вес (кг/шт)	A-B-C mm	e mm	h mm	Price list прайс-лист шт/у.е.	
					Pre-Galvanized Предв. Цинк-ия	Hot dip Galvanized гор.оцинк. HDZ
GMIT-10K D	1,000	100	1	9	10,00	14,00
GMIT-20K D	1,300	200	1	9	13,00	18,20
GMIT-30K D	2,150	300	1	9	21,50	30,10
GMIT-40K D	4,750	400	1.5	9	47,50	66,50
GMIT-50K D	6,500	500	1.5	9	65,00	91,00
GMIT-60K D	8,400	600	1.5	9	84,00	117,60

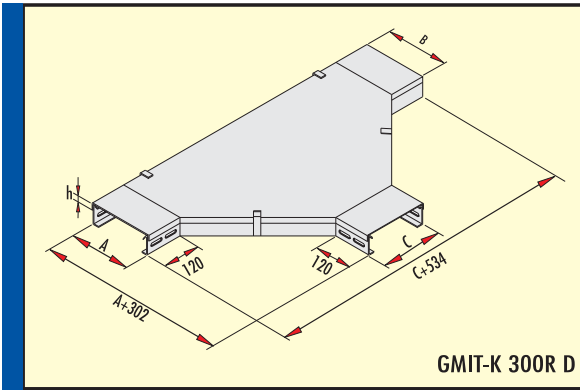

"T" Bağlantı Eleman Kapağı 300 Radüs

Tee "T" Element Cover Radius 300

Мишень "Т" Радиус Покрyтия Элемента 300

Sipariş kodu Order code Код заявки	Ağırlık (Kg/ad.) Weight (Kg/unit) Вес (кг/шт)	A-B-C mm	e mm	h mm	Price list прайс-лист шт/у.е.	
					Pre-Galvanized Предв. Цинк-ия	Hot dip Galvanized гор.оцинк. HDZ
GMIT-10K 300R D	1,900	100	1	9	19,00	26,60
GMIT-20K 300R D	2,500	200	1	9	25,00	35,00
GMIT-30K 300R D	3,800	300	1	9	38,00	53,20
GMIT-40K 300R D	8,150	400	1.5	9	81,50	114,10
GMIT-50K 300R D	10,900	500	1.5	9	109,00	152,60
GMIT-60K 300R D	13,420	600	1.5	9	134,20	187,88

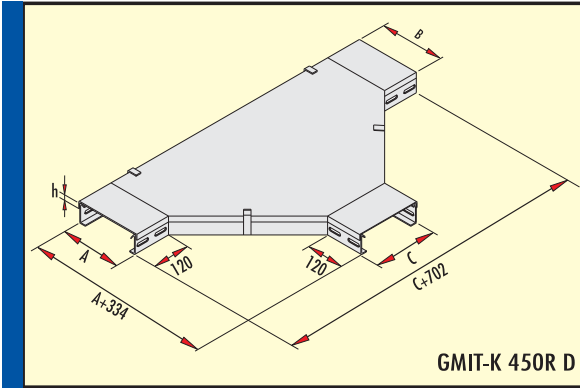

"T" Bağlantı Eleman Kapağı 450 Radüs

Tee "T" Element Cover Radius 450

Мишень "Т" Радиус Покрyтия Элемента 450

Sipariş kodu Order code Код заявки	Ağırlık (Kg/ad.) Weight (Kg/unit) Вес (кг/шт)	A-B-C mm	e mm	h mm	Price list прайс-лист шт/у.е.	
					Pre-Galvanized Предв. Цинк-ия	Hot dip Galvanized гор.оцинк. HDZ
GMIT-10K 450R D	2,800	100	1	9	28,00	39,20
GMIT-20K 450R D	3,300	200	1	9	33,00	46,20
GMIT-30K 450R D	4,900	300	1	9	49,00	68,60
GMIT-40K 450R D	9,900	400	1.5	9	99,00	138,60
GMIT-50K 450R D	12,900	500	1.5	9	129,00	180,60
GMIT-60K 450R D	16,100	600	1.5	9	161,00	225,40

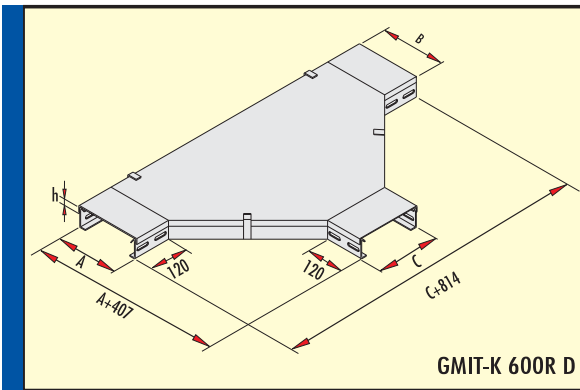

"T" Bağlantı Eleman Kapağı 600 Radüs

Tee "T" Element Cover Radius 600

Мишень "Т" Радиус Покрyтия Элемента 600

Sipariş kodu Order code Код заявки	Ağırlık (Kg/ad.) Weight (Kg/unit) Вес (кг/шт)	A-B-C mm	e mm	h mm	Price list прайс-лист шт/у.е.	
					Pre-Galvanized Предв. Цинк-ия	Hot dip Galvanized гор.оцинк. HDZ
GMIT-10K 600R D	3,100	100	1	9	31,00	43,40
GMIT-20K 600R D	3,800	200	1	9	38,00	53,20
GMIT-30K 600R D	6,120	300	1	9	61,20	85,68
GMIT-40K 600R D	12,200	400	1.5	9	122,00	170,80
GMIT-50K 600R D	15,400	500	1.5	9	154,00	215,60
GMIT-60K 600R D	19,000	600	1.5	9	190,00	266,00

Kaplama : TS 914 EN ISO-1461 (BS-EN-ISO-1461) Sıcak Daldırma Galvaniz. Coating : TS 914 EN ISO-1461 (BS-EN-ISO-1461) Hot Dip Galvanized

Talep üzerine tüm ürünler RODINA 50® malzemesi ile kaplanarak (max) 400°C ısıya, asit, tuz ve kum etkilerine karşı mukavemet sağlar.

In case of required all type of materials can be coated with RODINA 50® which will give on extra resistant at effect of 400°C heat, acid, salt and sand for the material.



**DÖRTLÜ BAĞLANTI ELEMANLARI** *Crossing Elements*  
Пересечение Элементов

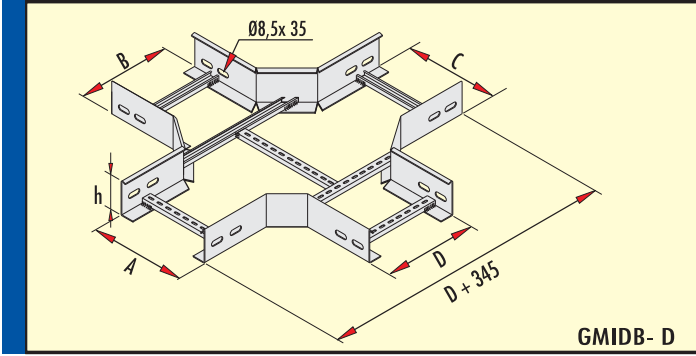

Sipariş kodu Order code Код заявки	Ağırlık (Kg/ad.) Weight (Kg/unit) Вес (кг./шт.)	A-B-C mm	h mm	e mm	Price list прайс-лист шт./у.е.	
					Pre-Galvanized Предв. Цинк-ия	Hot dip Galvanized гор.оцинк. HDZ
GMIDB-10 D	2,400	100	50	2	24,00	33,60
GMIDB-20 D	2,900	200	50	2	29,00	40,60
GMIDB-30 D	3,450	300	50	2	34,50	48,30
GMIDB-40 D	4,250	400	50	2	42,50	59,50
GMIDB-50 D	4,900	500	50	2	49,00	68,60
GMIDB-60 D	5,950	600	50	2	59,50	83,30
GMIDB-A10 D	2,800	100	60	2	28,00	39,20
GMIDB-A20 D	3,200	200	60	2	32,00	44,80
GMIDB-A30 D	3,750	300	60	2	37,50	52,50
GMIDB-A40 D	4,500	400	60	2	45,00	63,00
GMIDB-A50 D	5,350	500	60	2	53,50	74,90
GMIDB-A60 D	6,100	600	60	2	61,00	85,40
GMIDB-B10 D	3,000	100	70	2	30,00	42,00
GMIDB-B20 D	3,450	200	70	2	34,50	48,30
GMIDB-B30 D	4,000	300	70	2	40,00	56,00
GMIDB-B40 D	4,800	400	70	2	48,00	67,20
GMIDB-B50 D	5,750	500	70	2	57,50	80,50
GMIDB-B60 D	6,500	600	70	2	65,00	91,00

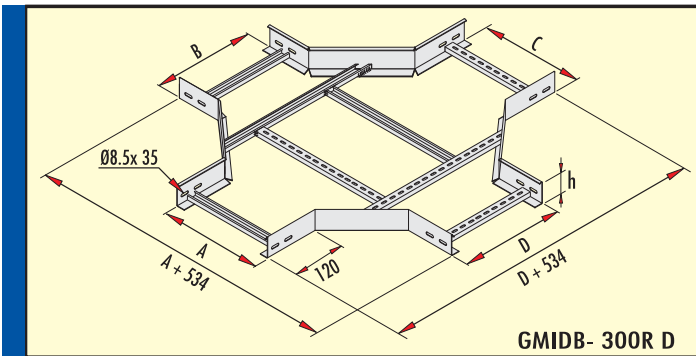

Sipariş kodu Order code Код заявки	Ağırlık (Kg/ad.) Weight (Kg/unit) Вес (кг./шт.)	A-B-C-D mm	h mm	e mm	Price list прайс-лист шт./у.е.	
					Pre-Galvanized Предв. Цинк-ия	Hot dip Galvanized гор.оцинк. HDZ
GMIDB-10 300R D	3,200	100	50	2	32,00	44,80
GMIDB-20 300R D	3,800	200	50	2	38,00	53,20
GMIDB-30 300R D	4,400	300	50	2	44,00	61,60
GMIDB-40 300R D	5,000	400	50	2	50,00	70,00
GMIDB-50 300R D	5,600	500	50	2	56,00	78,40
GMIDB-60 300R D	6,200	600	50	2	62,00	86,80
GMIDB-A10 300R D	3,600	100	60	2	36,00	50,40
GMIDB-A20 300R D	4,000	200	60	2	40,00	56,00
GMIDB-A30 300R D	4,600	300	60	2	46,00	64,40
GMIDB-A40 300R D	5,200	400	60	2	52,00	72,80
GMIDB-A50 300R D	5,800	500	60	2	58,00	81,20
GMIDB-A60 300R D	6,400	600	60	2	64,00	89,60
GMIDB-B10 300R D	3,650	100	70	2	36,50	51,10
GMIDB-B20 300R D	4,150	200	70	2	41,50	58,10
GMIDB-B30 300R D	4,750	300	70	2	47,50	66,50
GMIDB-B40 300R D	5,350	400	70	2	53,50	74,90
GMIDB-B50 300R D	5,950	500	70	2	59,50	83,30
GMIDB-B60 300R D	6,550	600	70	2	65,50	91,70

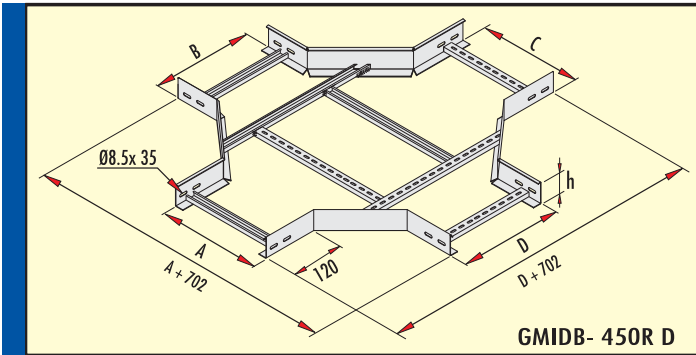

Sipariş kodu Order code Код заявки	Ağırlık (Kg/ad.) Weight (Kg/unit) Вес (кг./шт.)	A-B-C-D mm	h mm	e mm	Price list прайс-лист шт./у.е.	
					Pre-Galvanized Предв. Цинк-ия	Hot dip Galvanized гор.оцинк. HDZ
GMIDB-10 450R D	4,200	100	50	2	42,00	58,80
GMIDB-20 450R D	4,700	200	50	2	47,00	65,80
GMIDB-30 450R D	5,350	300	50	2	53,50	74,90
GMIDB-40 450R D	6,000	400	50	2	60,00	84,00
GMIDB-50 450R D	6,550	500	50	2	65,50	91,70
GMIDB-60 450R D	7,250	600	50	2	72,50	101,50
GMIDB-A10 450R D	4,450	100	60	2	44,50	62,30
GMIDB-A20 450R D	4,950	200	60	2	49,50	69,30
GMIDB-A30 450R D	5,550	300	60	2	55,50	77,70
GMIDB-A40 450R D	6,200	400	60	2	62,00	86,80
GMIDB-A50 450R D	6,850	500	60	2	68,50	95,90
GMIDB-A60 450R D	7,500	600	60	2	75,00	105,00
GMIDB-B10 450R D	4,900	100	70	2	49,00	68,60
GMIDB-B20 450R D	5,350	200	70	2	53,50	74,90
GMIDB-B30 450R D	6,000	300	70	2	60,00	84,00
GMIDB-B40 450R D	6,650	400	70	2	66,50	93,10
GMIDB-B50 450R D	7,300	500	70	2	73,00	102,20
GMIDB-B60 450R D	8,000	600	70	2	80,00	112,00

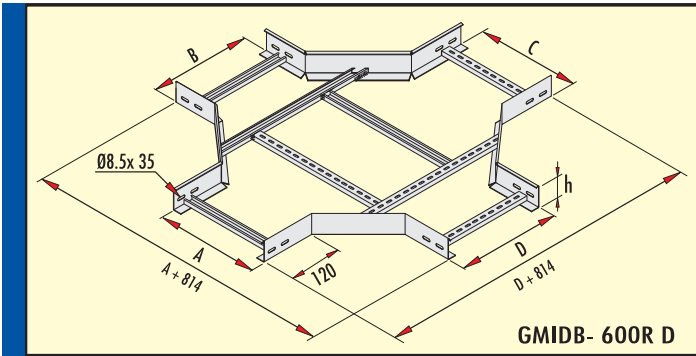

Sipariş kodu Order code Код заявки	Ağırlık (Kg/ad.) Weight (Kg/unit) Вес (кг./шт.)	A-B-C-D mm	h mm	e mm	Price list прайс-лист шт./у.е.	
					Pre-Galvanized Предв. Цинк-ия	Hot dip Galvanized гор.оцинк. HDZ
GMIDB-10 600R D	5,000	100	50	2	50,00	70,00
GMIDB-20 600R D	5,500	200	50	2	55,00	77,00
GMIDB-30 600R D	6,150	300	50	2	61,50	86,10
GMIDB-40 600R D	6,750	400	50	2	67,50	94,50
GMIDB-50 600R D	7,400	500	50	2	74,00	103,60
GMIDB-60 600R D	8,050	600	50	2	80,50	112,70
GMIDB-A10 600R D	5,100	100	60	2	51,00	71,40
GMIDB-A20 600R D	5,600	200	60	2	56,00	78,40
GMIDB-A30 600R D	6,300	300	60	2	63,00	88,20
GMIDB-A40 600R D	7,000	400	60	2	70,00	98,00
GMIDB-A50 600R D	7,550	500	60	2	75,50	105,70
GMIDB-A60 600R D	8,200	600	60	2	82,00	114,80
GMIDB-B10 600R D	5,800	100	70	2	58,00	81,20
GMIDB-B20 600R D	6,200	200	70	2	62,00	86,80
GMIDB-B30 600R D	6,800	300	70	2	68,00	95,20
GMIDB-B40 600R D	7,450	400	70	2	74,50	104,30
GMIDB-B50 600R D	8,100	500	70	2	81,00	113,40
GMIDB-B60 600R D	8,750	600	70	2	87,50	122,50

Kaplama : TS 914 EN ISO-1461 (BS-EN-ISO-1461) Sıcak Daldırma Galvaniz. Coating : TS 914 EN ISO-1461 (BS-EN-ISO-1461) Hot Dip Galvanized

Talep üzerine tüm ürünler RODINA 50® malzemesi ile kaplanarak (max) 400°C ısıya, asit, tuz ve kum etkilerine karşı mukavemet sağlar.  
In case of required all type of materials can be coated with RODINA 50® which will give on extra resistant at effect of 400°C heat, acid, salt and sand for the material.

DÖRTLÜ BAĞLANTI ELEMANLARI

Crossing Elements

Пересечение Покрытий Элемента

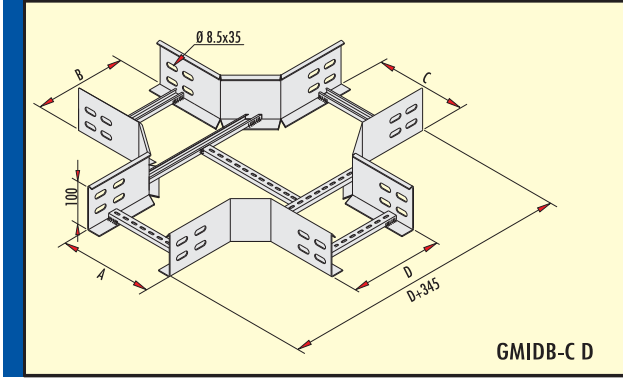

Dörtlü Bağlantı Elemanı (h=100 mm)

Crossing Element (h=100 mm)

Пересечение Покрытий Элемента

Sipariş kodu Order code Код заявки	Ağırlık (Kg/ad.) Weight (Kg/unit) Вес (кг/шт)	A-B-C-D mm	e mm	Price list прайс-лист шт/у.е.	
				Pre-Galvanized Предв. Цинк-ия	Hot dip Galvanized гор.оцинк. HDZ
GMIDB-C20 D	4,400	200	2	44,00	61,60
GMIDB-C30 D	5,300	300	2	53,00	74,20
GMIDB-C40 D	6,000	400	2	60,00	84,00
GMIDB-C50 D	6,700	500	2	67,00	93,80
GMIDB-C60 D	7,500	600	2	75,00	105,00

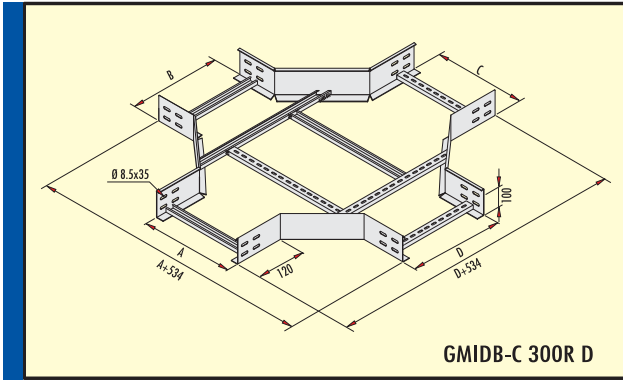

Dörtlü Bağlantı Elemanı 300 Radius (h=100 mm)

Crossing Element Radius 300 (h=100 mm)

Пересечение Радиуса Элемента 300

Sipariş kodu Order code Код заявки	Ağırlık (Kg/ad.) Weight (Kg/unit) Вес (кг/шт)	A-B-C-D mm	e mm	Price list прайс-лист шт/у.е.	
				Pre-Galvanized Предв. Цинк-ия	Hot dip Galvanized гор.оцинк. HDZ
GMIDB-C20 300R D	5,550	200	2	55,50	77,70
GMIDB-C30 300R D	6,550	300	2	65,50	91,70
GMIDB-C40 300R D	7,250	400	2	72,50	101,50
GMIDB-C50 300R D	8,050	500	2	80,50	112,70
GMIDB-C60 300R D	8,800	600	2	88,00	123,20

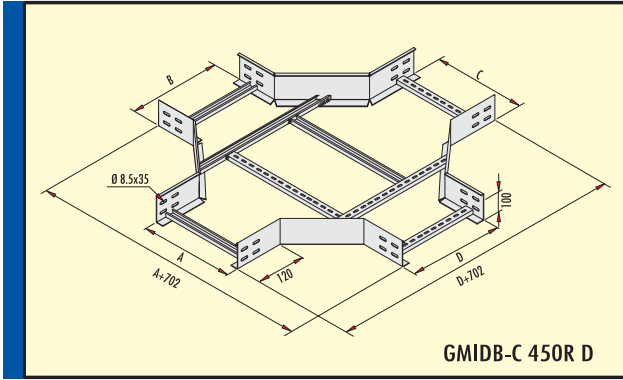

Dörtlü Bağlantı Elemanı 450 Radius (h=100 mm)

Crossing Element Radius 450 (h=100 mm)

Пересечение Радиуса Элемента 450

Sipariş kodu Order code Код заявки	Ağırlık (Kg/ad.) Weight (Kg/unit) Вес (кг/шт)	A-B-C-D mm	e mm	Price list прайс-лист шт/у.е.	
				Pre-Galvanized Предв. Цинк-ия	Hot dip Galvanized гор.оцинк. HDZ
GMIDB-C20 450R D	6,600	200	2	66,00	92,40
GMIDB-C30 450R D	7,600	300	2	76,00	106,40
GMIDB-C40 450R D	8,250	400	2	82,50	115,50
GMIDB-C50 450R D	9,000	500	2	90,00	126,00
GMIDB-C60 450R D	9,700	600	2	97,00	135,80

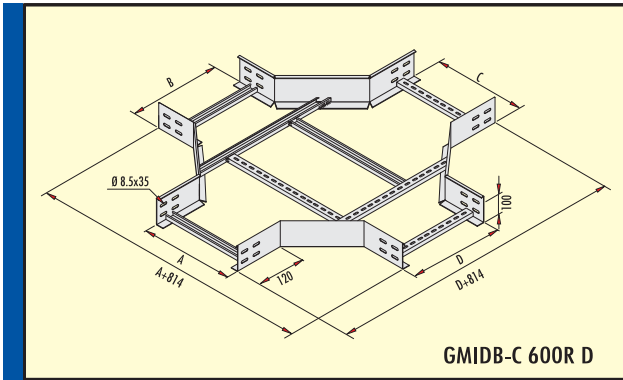

Dörtlü Bağlantı Elemanı 600 Radius (h=100 mm)

Crossing Element Radius 600 (h=100 mm)

Пересечение Радиуса Элемента 600

Sipariş kodu Order code Код заявки	Ağırlık (Kg/ad.) Weight (Kg/unit) Вес (кг/шт)	A-B-C-D mm	e mm	Price list прайс-лист шт/у.е.	
				Pre-Galvanized Предв. Цинк-ия	Hot dip Galvanized гор.оцинк. HDZ
GMIDB-C20 600R D	7,600	200	2	76,00	106,40
GMIDB-C30 600R D	8,600	300	2	86,00	120,40
GMIDB-C40 600R D	9,300	400	2	93,00	130,20
GMIDB-C50 600R D	10,100	500	2	101,00	141,40
GMIDB-C60 600R D	11,000	600	2	110,00	154,00

Kaplama : TS 914 EN ISO-1461 (BS-EN-ISO-1461) Sıcak Daldırma Galvaniz. Coating : TS 914 EN ISO-1461 (BS-EN-ISO-1461) Hot Dip Galvanized

Talep üzerine tüm ürünler RODINA 50® malzemesi ile kaplanarak (max) 400°C ısıya, asit, tuz ve kum etkilerine karşı mukavemet sağlar.

In case of required all type of materials can be coated with RODINA 50® which will give on extra resistant at effect of 400°C heat, acid, salt and sand for the material.

DÖRTLÜ BAĞLANTI ELEMANI KAPAKLARI *Crossing "T" Element Covers*

Пересечение Покрытий Элемента

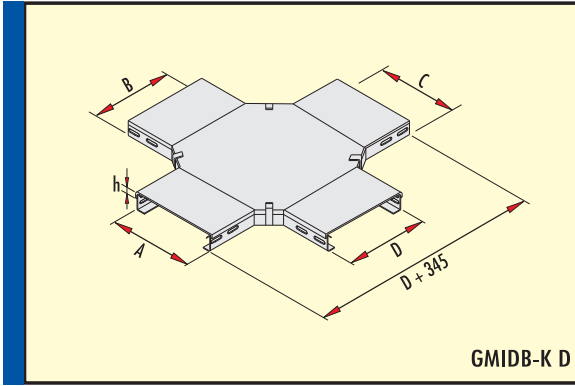

**Dörtlü Bağlantı Eleman Kapağı**

*Crossing Element Cover*

Пересечение Покрытий Элемента

Sipariş kodu Order code Код заявки	Ağırlık (Kg/ad.) Weight (Kg/unit) Вес (кг/шт)	A-B-C-D mm	e mm	h mm	Price list прайс-лист шт./у.е.	
					Pre-Galvanized Предв. Цинк-ия	Hot dip Galvanized гор.оцинк. HDZ
GMIDB-10K D	1,100	100	1	9	11,00	15,40
GMIDB-20K D	1,700	200	1	9	17,00	23,80
GMIDB-30K D	2,700	300	1	9	27,00	37,80
GMIDB-40K D	6,050	400	1.5	9	60,50	84,70
GMIDB-50K D	8,200	500	1.5	9	82,00	114,80
GMIDB-60K D	10,600	600	1.5	9	106,00	148,40

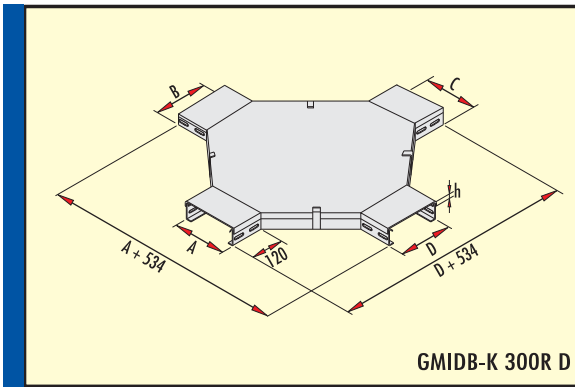

**Dörtlü Bağlantı Eleman Kapağı 300 Radüs**

*Crossing Element Cover Radius 300*

Пересечение Радиуса Покрытия Элемента 300

Sipariş kodu Order code Код заявки	Ağırlık (Kg/ad.) Weight (Kg/unit) Вес (кг/шт)	A-B-C-D mm	e mm	h mm	Price list прайс-лист шт./у.е.	
					Pre-Galvanized Предв. Цинк-ия	Hot dip Galvanized гор.оцинк. HDZ
GMIDB-10K 300R D	2,000	100	1	9	20,00	28,00
GMIDB-20K 300R D	3,300	200	1	9	33,00	46,20
GMIDB-30K 300R D	4,900	300	1	9	49,00	68,60
GMIDB-40K 300R D	10,000	400	1.5	9	100,00	140,00
GMIDB-50K 300R D	12,600	500	1.5	9	126,00	176,40
GMIDB-60K 300R D	15,700	600	1.5	9	157,00	219,80

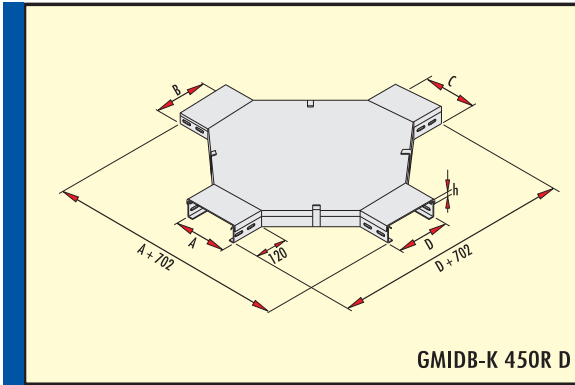

**Dörtlü Bağlantı Eleman Kapağı 450 Radüs**

*Crossing Element Cover Radius 450*

Пересечение Радиуса Покрытия Элемента 450

Sipariş kodu Order code Код заявки	Ağırlık (Kg/ad.) Weight (Kg/unit) Вес (кг/шт)	A-B-C-D mm	e mm	h mm	Price list прайс-лист шт./у.е.	
					Pre-Galvanized Предв. Цинк-ия	Hot dip Galvanized гор.оцинк. HDZ
GMIDB-10K 450R D	3,150	100	1	9	31,50	44,10
GMIDB-20K 450R D	4,550	200	1	9	45,50	63,70
GMIDB-30K 450R D	6,350	300	1	9	63,50	88,90
GMIDB-40K 450R D	12,600	400	1.5	9	126,00	176,40
GMIDB-50K 450R D	15,800	500	1.5	9	158,00	221,20
GMIDB-60K 450R D	16,400	600	1.5	9	164,00	229,60

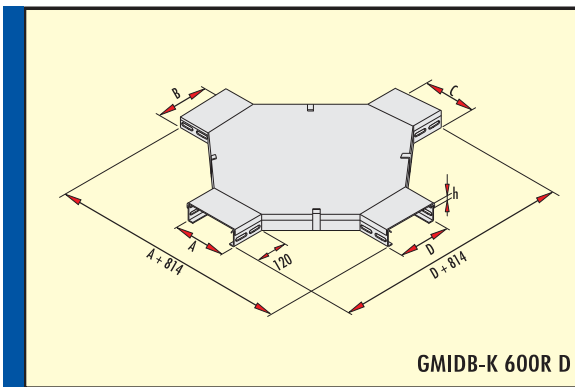

**Dörtlü Bağlantı Eleman Kapağı 600 Radüs**

*Crossing Element Cover Radius 600*

Пересечение Радиуса Покрытия Элемента 600

Sipariş kodu Order code Код заявки	Ağırlık (Kg/ad.) Weight (Kg/unit) Вес (кг/шт)	A-B-C-D mm	e mm	h mm	Price list прайс-лист шт./у.е.	
					Pre-Galvanized Предв. Цинк-ия	Hot dip Galvanized гор.оцинк. HDZ
GMIDB-10K 600R D	4,250	100	1	9	42,50	59,50
GMIDB-20K 600R D	6,250	200	1	9	62,50	87,50
GMIDB-30K 600R D	8,400	300	1	9	84,00	117,60
GMIDB-40K 600R D	16,000	400	1.5	9	160,00	224,00
GMIDB-50K 600R D	19,700	500	1.5	9	197,00	275,80
GMIDB-60K 600R D	23,550	600	1.5	9	235,50	329,70

Kaplama : TS 914 EN ISO-1461 (BS-EN-ISO-1461) Sıcak Daldırma Galvaniz. Coating : TS 914 EN ISO-1461 (BS-EN-ISO-1461) Hot Dip Galvanized

Talep üzerine tüm ürünler RODINA 50® malzemesi ile kaplanarak (max) 400°C ısıya, asit, tuz ve kum etkilerine karşı mukavemet sağlar.

In case of required all type of materials can be coated with RODINA 50® which will give on extra resistant at effect of 400°C heat, acid, salt and sand for the material.

135° DÖNÜŞ ELEMANLARI

135° Flat Bend Elements

135° Квартир Сгибают Элементы

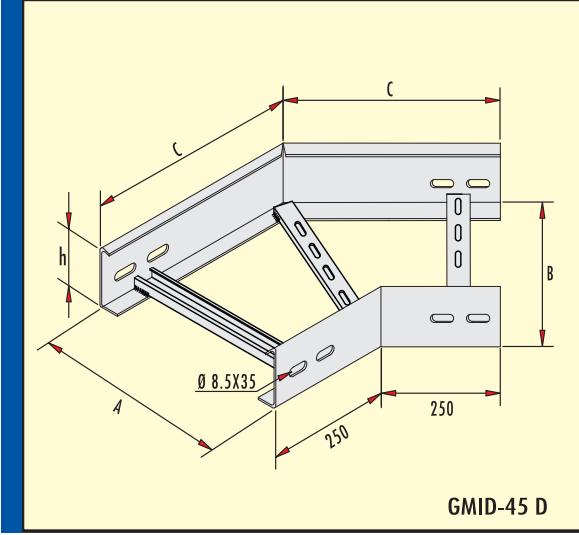

135° Dönüş Elemanı

135° Flat Bend Element

135° Квартир Сгибают Элемент

Sipariş kodu Order code Код заявки	Ağırlık (Kg/ad.) Weight (Kg/unit) Вес (кг/шт)	A-B mm	C mm	e mm	h mm	Price list прайс-лист шт/у.е.	
						Pre-Galvanized Предв. Цинк-ия	Hot dip Galvanized гор.оцинк. HDZ
GMID-10-45 D	1,600	100	333	2	50	16,00	22,40
GMID-20-45 D	1,950	200	333	2	50	19,50	27,30
GMID-30-45 D	2,300	300	374	2	50	23,00	32,20
GMID-40-45 D	2,600	400	416	2	50	26,00	36,40
GMID-50-45 D	2,950	500	457	2	50	29,50	41,30
GMID-60-45 D	3,250	600	499	2	50	32,50	45,50
GMID-A10-45 D	1,850	100	333	2	60	18,50	25,90
GMID-A20-45 D	2,050	200	333	2	60	20,50	28,70
GMID-A30-45 D	2,400	300	374	2	60	24,00	33,60
GMID-A40-45 D	2,750	400	416	2	60	27,50	38,50
GMID-A50-45 D	3,100	500	457	2	60	31,00	43,40
GMID-A60-45 D	3,450	600	499	2	60	34,50	48,30
GMID-B10-45 D	2,100	100	333	2	70	21,00	29,40
GMID-B20-45 D	2,400	200	333	2	70	24,00	33,60
GMID-B30-45 D	2,750	300	374	2	70	27,50	38,50
GMID-B40-45 D	3,050	400	416	2	70	30,50	42,70
GMID-B50-45 D	3,400	500	457	2	70	34,00	47,60
GMID-B60-45 D	3,750	600	499	2	70	37,50	52,50

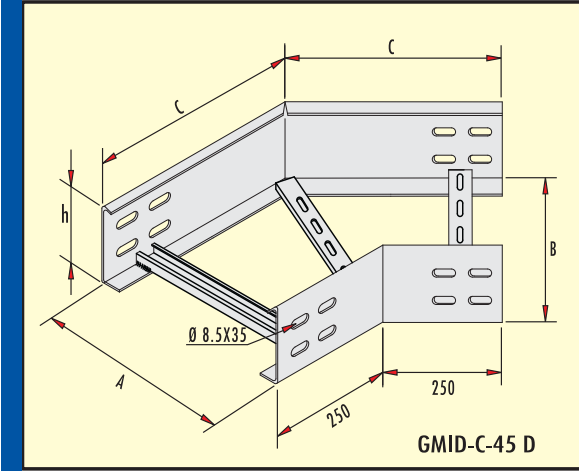

135° Dönüş Elemanı (h=100 mm)

135° Flat Bend Element (h=100 mm)

135° Квартир Сгибают Элемент

Sipariş kodu Order code Код заявки	Ağırlık (Kg/ad.) Weight (Kg/unit) Вес (кг/шт)	A-B mm	C mm	e mm	h mm	Price list прайс-лист шт/у.е.	
						Pre-Galvanized Предв. Цинк-ия	Hot dip Galvanized гор.оцинк. HDZ
GMID-C20-45 D	2,650	200	333	2	100	26,50	37,10
GMID-C30-45 D	3,050	300	374	2	100	30,50	42,70
GMID-C40-45 D	3,450	400	416	2	100	34,50	48,30
GMID-C50-45 D	3,850	500	457	2	100	38,50	53,90
GMID-C60-45 D	4,250	600	499	2	100	42,50	59,50

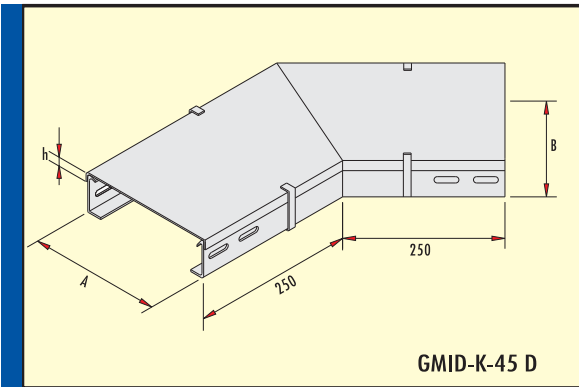

135° Dönüş Eleman Kapağı

135° Flat Bend Element Cover

135° Квартир Сгибают Покрытие Элемента

Sipariş kodu Order code Код заявки	Ağırlık (Kg/ad.) Weight (Kg/unit) Вес (кг/шт)	A mm	B mm	e mm	h mm	Price list прайс-лист шт/у.е.	
						Pre-Galvanized Предв. Цинк-ия	Hot dip Galvanized гор.оцинк. HDZ
GMID-10K-45 D	0,700	100	100	1	9	7,00	9,80
GMID-20K-45 D	1,050	200	200	1	9	10,50	14,70
GMID-30K-45 D	1,600	300	300	1	9	16,00	22,40
GMID-40K-45 D	3,200	400	400	1,5	9	32,00	44,80
GMID-50K-45 D	4,400	500	500	1,5	9	44,00	61,60
GMID-60K-45 D	5,500	600	600	1,5	9	55,00	77,00

Kaplama : TS 914 EN ISO-1461 (BS-EN-ISO-1461) Sıcak Daldırma Galvaniz. Coating : TS 914 EN ISO-1461 (BS-EN-ISO-1461) Hot Dip Galvanized

Talep üzerine tüm ürünler RODINA 50® malzemesi ile kaplanarak (max) 400°C ısıya, asit, tuz ve kum etkilerine karşı mukavemet sağlar.

In case of required all type of materials can be coated with RODINA 50® which will give on extra resistant at effect of 400°C heat, acid, salt and sand for the material.



## İÇ-DIŞ BÜKEY BAĞLANTI ELEMANLARI Inside and Outside Vertical Bends Elements

Внутри и снаружи Вертикальных Элементов Изгибов

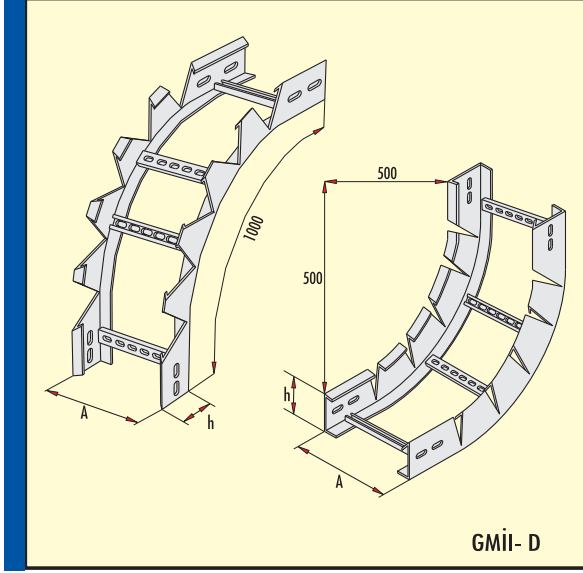

### İç-Dış Bükey Bağlantı Elemanı

#### Inside and Outside Vertical Bend Element

Внутри и снаружи Вертикальных Элементов Изгибов

Sipariş kodu Order code Код заявки	Ağırlık (Kg/ad.) Weight (Kg/unit) Вес (кг/шт)	A-B mm	e mm	h mm	Price list прайс-лист шт/у.е.	
					Pre-Galvanized Предв. Цинк-ия	Hot dip Galvanized гор.оцинк. HDZ
GMII-10 D	2,700	100	2	50	27,00	37,80
GMII-20 D	3,000	200	2	50	30,00	42,00
GMII-30 D	3,290	300	2	50	32,90	46,06
GMII-40 D	3,500	400	2	50	35,00	49,00
GMII-50 D	3,730	500	2	50	37,30	52,22
GMII-60 D	3,900	600	2	50	39,00	54,60
GMII-A10 D	3,150	100	2	60	31,50	44,10
GMII-A20 D	3,350	200	2	60	33,50	46,90
GMII-A30 D	3,570	300	2	60	35,70	49,98
GMII-A40 D	3,800	400	2	60	38,00	53,20
GMII-A50 D	4,000	500	2	60	40,00	56,00
GMII-A60 D	4,200	600	2	60	42,00	58,80
GMII-B10 D	3,400	100	2	70	34,00	47,60
GMII-B20 D	3,600	200	2	70	36,00	50,40
GMII-B30 D	3,800	300	2	70	38,00	53,20
GMII-B40 D	4,000	400	2	70	40,00	56,00
GMII-B50 D	4,250	500	2	70	42,50	59,50
GMII-B60 D	4,430	600	2	70	44,30	62,02

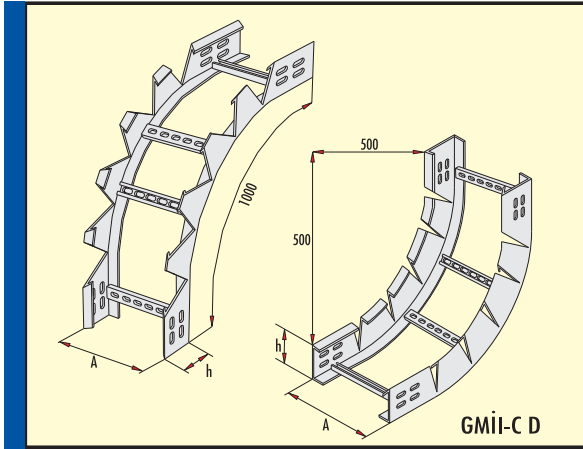

### İç-Dış Bükey Bağlantı Elemanı (h=100 mm)

#### Inside and Outside Vertical Bend Element (h=100 mm)

Внутри и снаружи Вертикальных Элементов Изгибов

Sipariş kodu Order code Код заявки	Ağırlık (Kg/ad.) Weight (Kg/unit) Вес (кг/шт)	A-B mm	e mm	h mm	Price list прайс-лист шт/у.е.	
					Pre-Galvanized Предв. Цинк-ия	Hot dip Galvanized гор.оцинк. HDZ
GMII-C20 D	5,600	200	2	100	56,00	78,40
GMII-C30 D	6,000	300	2	100	60,00	84,00
GMII-C40 D	6,420	400	2	100	64,20	89,88
GMII-C50 D	6,800	500	2	100	68,00	95,20
GMII-C60 D	7,000	600	2	100	70,00	98,00

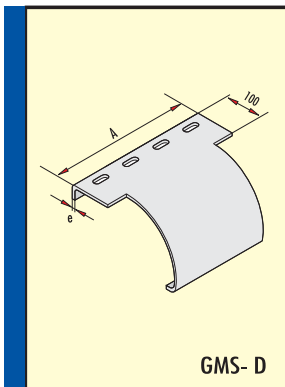

### Kablo Merdiveni Çıkış Alma Elemanı

#### Cable Externalizing Unit

наружный элемент кабельных лестниц

Sipariş kodu Order code Код заявки	Ağırlık (Kg/ad.) Weight (Kg/unit) Вес (кг/шт)	A-B mm	e mm	Price list прайс-лист шт/у.е.	
				Pre-Galvanized Предв. Цинк-ия	Hot dip Galvanized гор.оцинк. HDZ
GMS-10 D	0,650	95	1.5	6,50	9,10
GMS-20 D	0,850	195	1.5	8,50	11,90
GMS-30 D	1,400	295	1.5	14,00	19,60
GMS-40 D	2,650	395	2	26,50	37,10
GMS-50 D	3,400	495	2	34,00	47,60
GMS-60 D	4,150	595	2	41,50	58,10

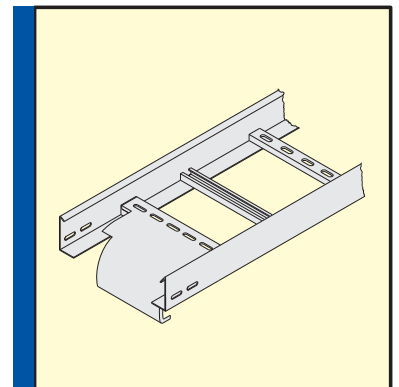

Kaplama : TS 914 EN ISO-1461 (BS-EN-ISO-1461) Sıcak Daldırma Galvaniz. Coating : TS 914 EN ISO-1461 (BS-EN-ISO-1461) Hot Dip Galvanized

Talep üzerine tüm ürünler RODINA 50® malzemesi ile kaplanarak (max) 400°C ısıya, asit, tuz ve kum etkilerine karşı mukavemet sağlar.

In case of required all type of materials can be coated with RODINA 50® which will give on extra resistant at effect of 400°C heat, acid, salt and sand for the material.



## RADÜSLÜ DÖNÜŞ ELEMANLARI

## Flat Bends

## Угловые элементы

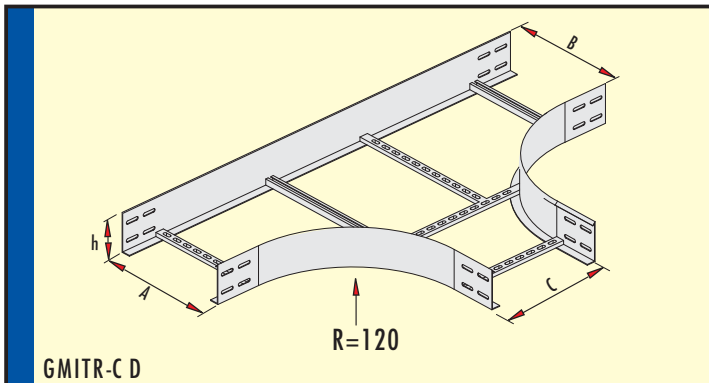
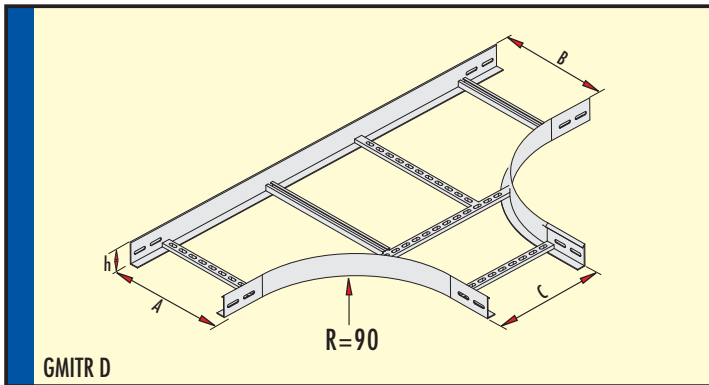
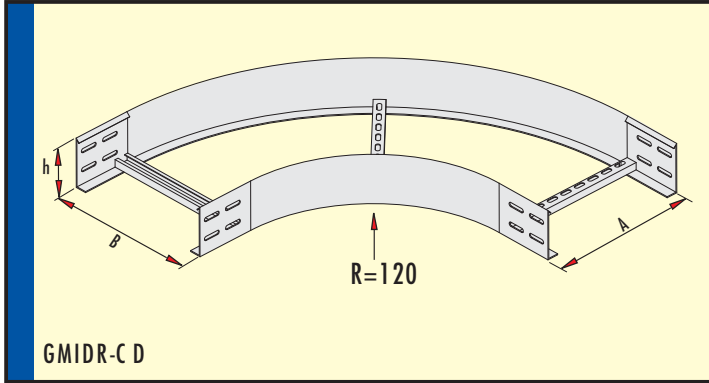
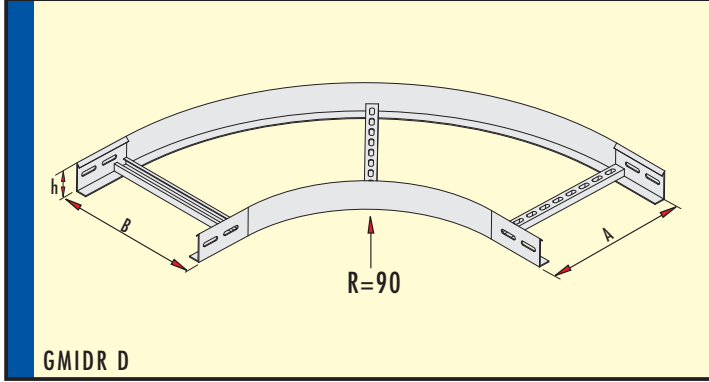

Bağlantı elemanları isteğe bağlı olarak 150-300-450-600-900 Radüslü imal edilir.  
Circlar can be produced with 150-300-450-600-900 Radius.

**90° Dönüş Elemanı 90° Flat Bend**  
угловые элементы 90°

Sipariş kodu Order code Код заявки	Ağırlık (Kg/ad.) Weight (Kg/unit) Вес (кг/шт)	A-B mm	h mm	e mm	Price list прайс-лист шт/у.е.	
					Pre-Galvanized Предв. Цинк-ия	Hot dip Galvanized гор.оцинк. HDZ
GMIDR-10 D	1,500	100	50	2		21,00
GMIDR-20 D	1,940	200	50	2		27,16
GMIDR-30 D	2,380	300	50	2		33,32
GMIDR-40 D	3,030	400	50	2		42,42
GMIDR-50 D	3,520	500	50	2		49,28
GMIDR-60 D	4,010	600	50	2		56,14
GMIDR-A10 D	1,650	100	60	2		23,10
GMIDR-A20 D	2,110	200	60	2		29,54
GMIDR-A30 D	2,570	300	60	2		35,98
GMIDR-A40 D	3,250	400	60	2		45,50
GMIDR-A50 D	3,760	500	60	2		52,64
GMIDR-A60 D	4,280	600	60	2		59,92
GMIDR-B10 D	1,790	100	70	2		25,06
GMIDR-B20 D	2,280	200	70	2		31,92
GMIDR-B30 D	2,760	300	70	2		38,64
GMIDR-B40 D	3,470	400	70	2		48,58
GMIDR-B50 D	4,010	500	70	2		56,14
GMIDR-B60 D	4,550	600	70	2		63,70

**90° Dönüş Elemanı (h=100 mm)**  
**90° Flat Bend (h=100 mm)**  
угловые элементы 90°

Sipariş kodu Order code Код заявки	Ağırlık (Kg/ad.) Weight (Kg/unit) Вес (кг/шт)	A-B mm	h mm	e mm	Price list прайс-лист шт/у.е.	
					Pre-Galvanized Предв. Цинк-ия	Hot dip Galvanized гор.оцинк. HDZ
GMIDR-C10	2,500	100	100	2		35,00
GMIDR-C20	2,970	200	100	2		41,58
GMIDR-C30	3,850	300	100	2		53,90
GMIDR-C40	4,580	400	100	2		64,12
GMIDR-C50	5,690	500	100	2		79,66
GMIDR-C60	6,500	600	100	2		91,00

**T Bağlantı Elemanı Tees "T"**  
«Т» образные соединительные элементы

Sipariş kodu Order code Код заявки	Ağırlık (Kg/ad.) Weight (Kg/unit) Вес (кг/шт)	A-B-C mm	h mm	e mm	Price list прайс-лист шт/у.е.	
					Pre-Galvanized Предв. Цинк-ия	Hot dip Galvanized гор.оцинк. HDZ
GMITR-10	2,070	100	50	2		28,98
GMITR-20	2,480	200	50	2		34,72
GMITR-30	3,050	300	50	2		42,70
GMITR-40	3,520	400	50	2		49,28
GMITR-50	3,980	500	50	2		55,72
GMITR-60	4,450	600	50	2		62,30
GMITR-A10	2,270	100	60	2		31,78
GMITR-A20	2,700	200	60	2		37,80
GMITR-A30	3,280	300	60	2		45,92
GMITR-A40	3,760	400	60	2		52,64
GMITR-A50	4,240	500	60	2		59,36
GMITR-A60	4,730	600	60	2		66,22
GMITR-B10	2,470	100	70	2		34,58
GMITR-B20	2,910	200	70	2		40,74
GMITR-B30	3,520	300	70	2		49,28
GMITR-B40	4,010	400	70	2		56,14
GMITR-B50	4,510	500	70	2		63,14
GMITR-B60	5,000	600	70	2		70,00

**T Bağlantı Elemanı (h=100 mm)**  
**Tees "T" (h=100 mm)**  
«Т» образные соединительные элементы

Sipariş kodu Order code Код заявки	Ağırlık (Kg/ad.) Weight (Kg/unit) Вес (кг/шт)	A-B-C mm	h mm	e mm	Price list прайс-лист шт/у.е.	
					Pre-Galvanized Предв. Цинк-ия	Hot dip Galvanized гор.оцинк. HDZ
GMITR-C10	3,300	100	100	2		46,20
GMITR-C20	3,800	200	100	2		53,20
GMITR-C30	4,400	300	100	2		61,60
GMITR-C40	4,850	400	100	2		67,90
GMITR-C50	5,980	500	100	2		83,72
GMITR-C60	6,670	600	100	2		93,38

## RADÜSLÜ DÖNÜŞ ELEMANLARI

## Flat Bends

## Угловые элементы

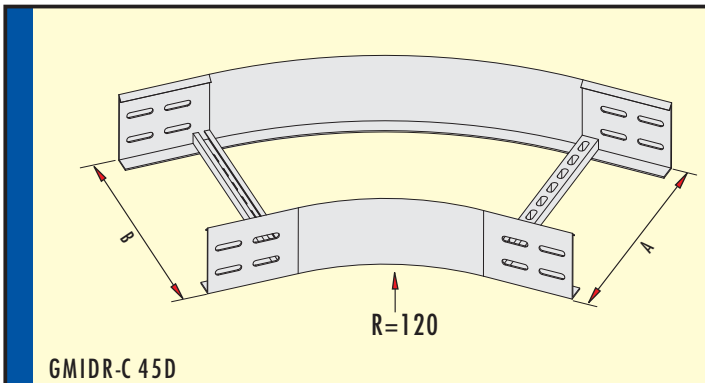
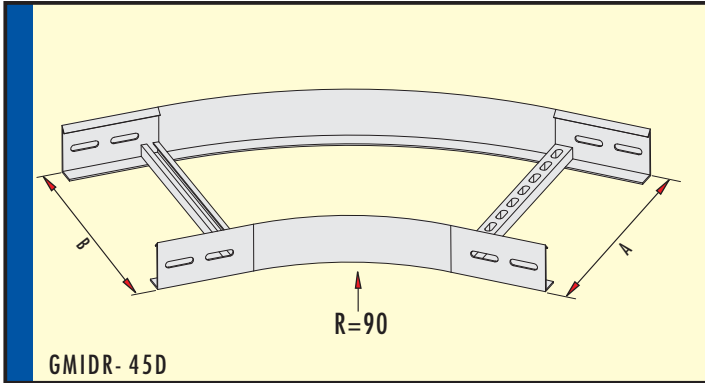
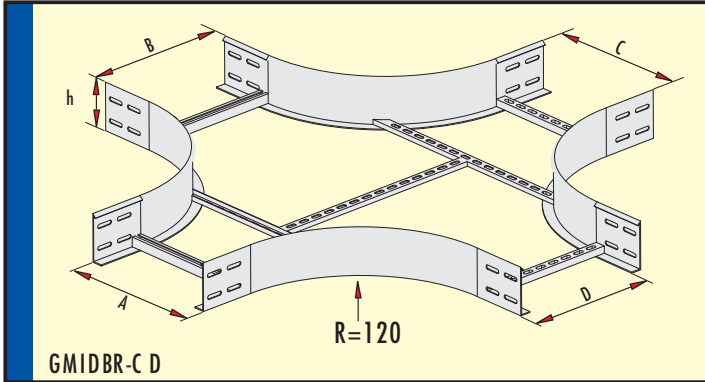
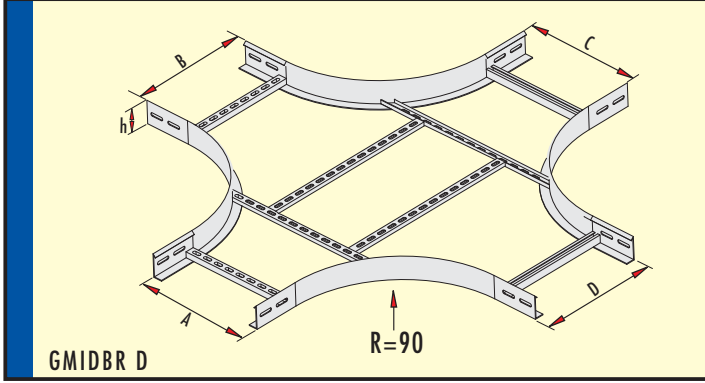

Bağlantı elemanları isteğe bağlı olarak 150-300-450-600-900 Radüslü imal edilir.  
Circles can be produced with 150-300-450-600-900 Radius.

### Dörtlü Bağlantı Elemanı Crossing Element Пересечение Покрытый Элемента

Sipariş kodu Order code Код заявки	Ağırlık (Kg/ad.) Weight (Kg/unit) Вес (кг/шт)	A-B-C-D mm	h mm	e mm	Price list прайс-лист шт/у.е.	
					Pre-Galvanized Предв. Цинк-ия	Hot dip Galvanized гор.оцинк. HDZ
GMIDBR-10D	2,400	100	50	2		33,60
GMIDBR-20D	2,670	200	50	2		37,38
GMIDBR-30D	3,100	300	50	2		43,40
GMIDBR-40D	3,420	400	50	2		47,88
GMIDBR-50D	3,750	500	50	2		52,50
GMIDBR-60D	4,070	600	50	2		56,98
GMIDBR-A10D	2,640	100	60	2		36,96
GMIDBR-A20D	2,910	200	60	2		40,74
GMIDBR-A30D	3,340	300	60	2		46,76
GMIDBR-A40D	3,660	400	60	2		51,24
GMIDBR-A50D	3,990	500	60	2		55,86
GMIDBR-A60D	4,310	600	60	2		60,34
GMIDBR-B10D	2,890	100	70	2		40,46
GMIDBR-B20D	3,160	200	70	2		44,24
GMIDBR-B30D	3,590	300	70	2		50,26
GMIDBR-B40D	3,910	400	70	2		54,74
GMIDBR-B50D	4,240	500	70	2		59,36
GMIDBR-B60D	4,560	600	70	2		63,84

### Dörtlü Bağlantı Elemanı (h=100 mm) Crossing Element (h=100 mm)

Sipariş kodu Order code Код заявки	Ağırlık (Kg/ad.) Weight (Kg/unit) Вес (кг/шт)	A-B-C-D mm	h mm	e mm	Price list прайс-лист шт/у.е.	
					Pre-Galvanized Предв. Цинк-ия	Hot dip Galvanized гор.оцинк. HDZ
GMIDBR-C10 D	3,700	100	100	2		51,80
GMIDBR-C20 D	4,250	200	100	2		59,50
GMIDBR-C30 D	4,410	300	100	2		61,74
GMIDBR-C40 D	5,780	400	100	2		80,92
GMIDBR-C50 D	6,390	500	100	2		89,46
GMIDBR-C60 D	7,010	600	100	2		98,14

### 135° Dönüş Elemanı 135° Flat Bend Element

135° Квартир Стигают Элемент

Sipariş kodu Order code Код заявки	Ağırlık (Kg/ad.) Weight (Kg/unit) Вес (кг/шт)	A-B mm	h mm	e mm	Price list прайс-лист шт/у.е.	
					Pre-Galvanized Предв. Цинк-ия	Hot dip Galvanized гор.оцинк. HDZ
GMIDR-10-45 D	1,050	100	50	2		14,70
GMIDR-20-45 D	1,140	200	50	2		15,96
GMIDR-30-45 D	1,520	300	50	2		21,28
GMIDR-40-45 D	2,180	400	50	2		30,52
GMIDR-50-45 D	2,500	500	50	2		35,00
GMIDR-60-45 D	2,830	600	50	2		39,62
GMIDR-A10-45 D	1,250	100	60	2		17,50
GMIDR-A20-45 D	1,530	200	60	2		21,42
GMIDR-A30-45 D	1,980	300	60	2		27,72
GMIDR-A40-45 D	2,320	400	60	2		32,48
GMIDR-A50-45 D	2,660	500	60	2		37,24
GMIDR-A60-45 D	3,000	600	60	2		42,00
GMIDR-B10-45 D	1,360	100	70	2		19,04
GMIDR-B20-45 D	1,660	200	70	2		23,24
GMIDR-B30-45 D	2,120	300	70	2		29,68
GMIDR-B40-45 D	2,470	400	70	2		34,58
GMIDR-B50-45 D	2,820	500	70	2		39,48
GMIDR-B60-45 D	3,170	600	70	2		44,38

### 135° Dönüş Elemanı (h=100 mm) 135° Flat Bend Element (h=100 mm)

135° Квартир Стигают Элемент

Sipariş kodu Order code Код заявки	Ağırlık (Kg/ad.) Weight (Kg/unit) Вес (кг/шт)	A-B mm	h mm	e mm	Price list прайс-лист шт/у.е.	
					Pre-Galvanized Предв. Цинк-ия	Hot dip Galvanized гор.оцинк. HDZ
GMIDR-C10-45 D	1,560	100	100	2		21,84
GMIDR-C20-45 D	2,160	200	100	2		30,24
GMIDR-C30-45 D	2,560	300	100	2		35,84
GMIDR-C40-45 D	3,270	400	100	2		45,78
GMIDR-C50-45 D	3,750	500	100	2		52,50
GMIDR-C60-45 D	4,230	600	100	2		59,22

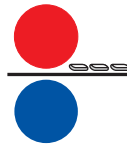

## RADÜSLÜ DÖNÜŞ ELEMANLARI

## Flat Bends

## Угловые элементы

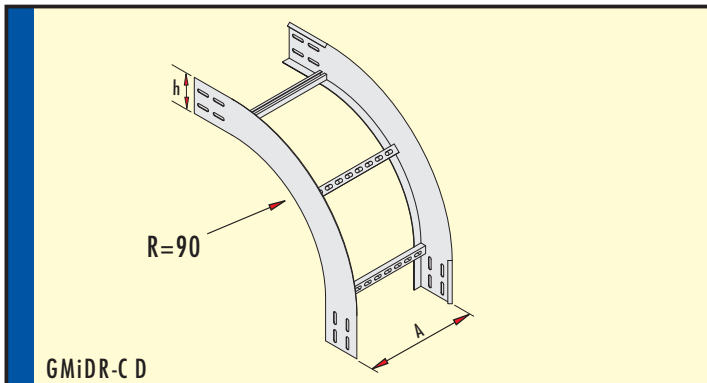
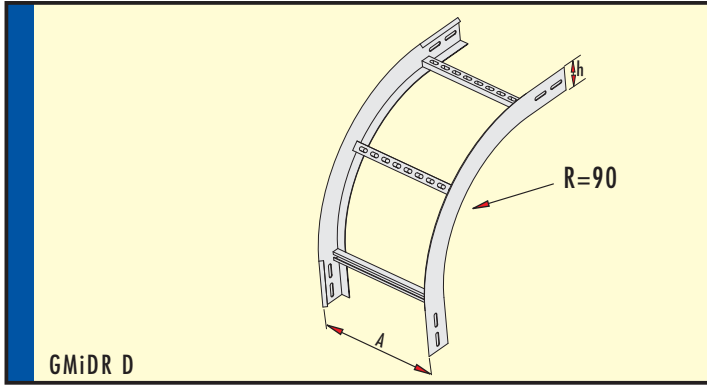
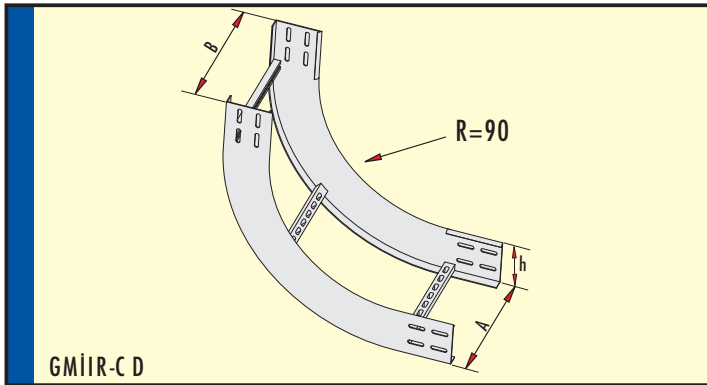
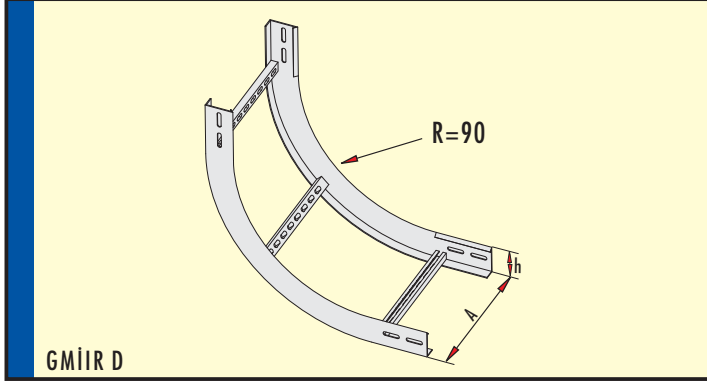

Bağlantı elemanları isteğe bağlı olarak 150-300-450-600-900 Radüslü imal edilir.  
Circles can be produced with 150-300-450-600-900 Radius.

İç Bükey Elemanı Inside Vertical Bend						
Внутри и снаружи Вертикальных Изгибов						
Sipariş kodu Order code Код заявки	Ağırlık (Kg/ad.) Weight (Kg/unit) Вес (кг/шт)	A mm	h mm	e mm	Price list прайс-лист шт/у.е.	
					Pre-Galvanized Предв. Цинк-ия	Hot dip Galvanized гор.оцинк. HDZ
GMiIR-10D	1,230	100	50	2		17,22
GMiIR-20D	1,340	200	50	2		18,76
GMiIR-30D	1,550	300	50	2		21,70
GMiIR-40D	1,720	400	50	2		24,08
GMiIR-50D	1,880	500	50	2		26,32
GMiIR-60D	2,040	600	50	2		28,56
GMiIR-A10D	1,350	100	60	2		18,90
GMiIR-A20D	1,510	200	60	2		21,14
GMiIR-A30D	1,670	300	60	2		23,38
GMiIR-A40D	1,830	400	60	2		25,62
GMiIR-A50D	2,000	500	60	2		28,00
GMiIR-A60D	2,160	600	60	2		30,24
GMiIR-B10D	1,470	100	70	2		20,58
GMiIR-B20D	1,630	200	70	2		22,82
GMiIR-B30D	1,790	300	70	2		25,06
GMiIR-B40D	1,950	400	70	2		27,30
GMiIR-B50D	2,120	500	70	2		29,68
GMiIR-B60D	2,280	600	70	2		31,92

İç Bükey Elemanı Inside Vertical Bend						
Внутри и снаружи Вертикальных Изгибов						
Sipariş kodu Order code Код заявки	Ağırlık (Kg/ad.) Weight (Kg/unit) Вес (кг/шт)	A mm	h mm	e mm	Price list прайс-лист шт/у.е.	
					Pre-Galvanized Предв. Цинк-ия	Hot dip Galvanized гор.оцинк. HDZ
GMiIR-C10D	1,600	100	100	2		22,40
GMiIR-C20D	2,130	200	100	2		29,82
GMiIR-C30D	2,360	300	100	2		33,04
GMiIR-C40D	2,590	400	100	2		36,26
GMiIR-C50D	2,820	500	100	2		39,48
GMiIR-C60D	3,050	600	100	2		42,70

Dış Bükey Elemanı Outside Vertical Bend						
Внутри и снаружи Вертикальных Изгибов						
Sipariş kodu Order code Код заявки	Ağırlık (Kg/ad.) Weight (Kg/unit) Вес (кг/шт)	A mm	h mm	e mm	Price list прайс-лист шт/у.е.	
					Pre-Galvanized Предв. Цинк-ия	Hot dip Galvanized гор.оцинк. HDZ
GMiDR-10 D	2,070	100	50	2		28,98
GMiDR-20 D	2,480	200	50	2		34,72
GMiDR-30 D	3,050	300	50	2		42,70
GMiDR-40 D	3,520	400	50	2		49,28
GMiDR-50 D	3,980	500	50	2		55,72
GMiDR-60 D	4,450	600	50	2		62,30
GMiDR-A10 D	2,270	100	60	2		31,78
GMiDR-A20 D	2,700	200	60	2		37,80
GMiDR-A30 D	3,280	300	60	2		45,92
GMiDR-A40 D	3,760	400	60	2		52,64
GMiDR-A50 D	4,240	500	60	2		59,36
GMiDR-A60 D	4,730	600	60	2		66,22
GMiDR-B10 D	2,470	100	70	2		34,58
GMiDR-B20 D	2,910	200	70	2		40,74
GMiDR-B30 D	3,520	300	70	2		49,28
GMiDR-B40 D	4,010	400	70	2		56,14
GMiDR-B50 D	4,510	500	70	2		63,14
GMiDR-B60 D	5,000	600	70	2		70,00

Dış Bükey Elemanı Outside Vertical Bend						
Внутри и снаружи Вертикальных Изгибов						
Sipariş kodu Order code Код заявки	Ağırlık (Kg/ad.) Weight (Kg/unit) Вес (кг/шт)	A mm	h mm	e mm	Price list прайс-лист шт/у.е.	
					Pre-Galvanized Предв. Цинк-ия	Hot dip Galvanized гор.оцинк. HDZ
GMiDR-C10 D	3,300	100	100	2		46,20
GMiDR-C20 D	3,800	200	100	2		53,20
GMiDR-C30 D	4,400	300	100	2		61,60
GMiDR-C40 D	4,850	400	100	2		67,90
GMiDR-C50 D	5,980	500	100	2		83,72
GMiDR-C60 D	6,670	600	100	2		93,38



## RADÜSLÜ DÖNÜŞ ELEMAN KAPAKLARI

## Flat Bend Covers

Плоских Покрытий Изгиба

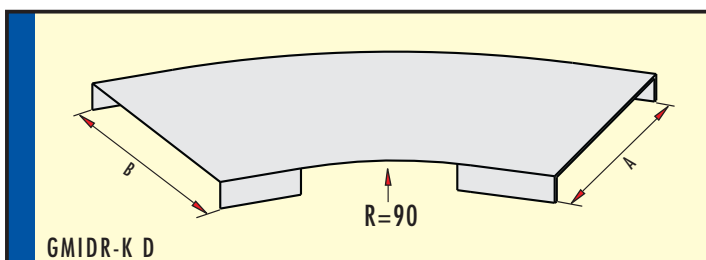
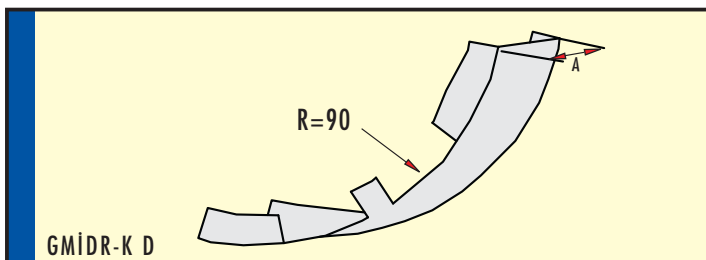
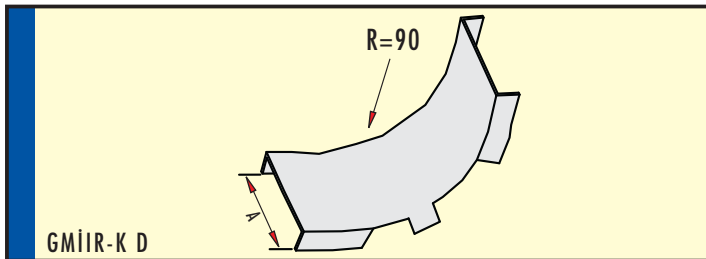
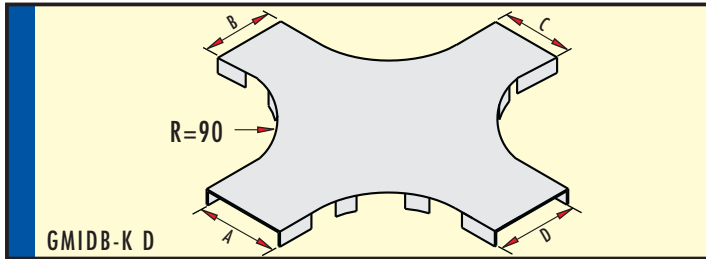
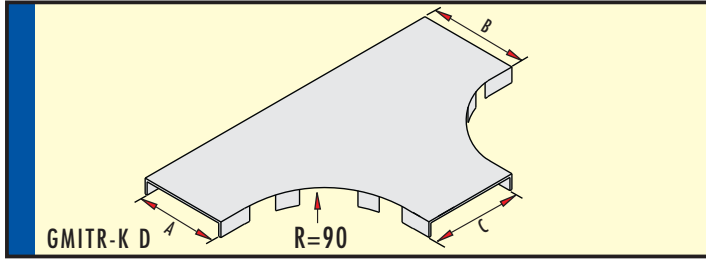
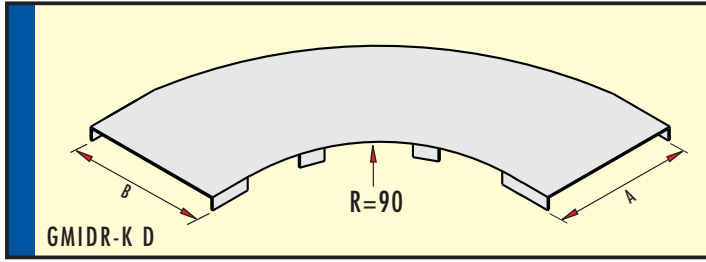

### 90° Dönüş Kapakı 90° Flat Bend Cover

«Т» образные соединительные элементы

Sipariş kodu Order code Код заявки	Ağırlık (Kg/ad.) Weight (Kg/unit) Вес (кг /шт)	A-B mm	e mm	Price list прайс-лист шт /у.е.	
				Pre-Galvanized Предв. Цинк-ия	Hot dip Galvanized гор.оцинк. HDZ
GMIDR-10K D	0.450	100	1		6,30
GMIDR-20K D	0.960	200	1		13,50
GMIDR-30K D	1.590	300	1		22,30
GMIDR-40K D	3.520	400	1,5		49,30
GMIDR-50K D	4.830	500	1,5		67,70
GMIDR-60K D	6.350	600	1,5		88,90

### T Bağlantı Kapakı Tees "T" Cover

«Т» образные соединительные элементы

Sipariş kodu Order code Код заявки	Ağırlık (Kg/ad.) Weight (Kg/unit) Вес (кг /шт)	A-B-C mm	e mm	Price list прайс-лист шт /у.е.	
				Pre-Galvanized Предв. Цинк-ия	Hot dip Galvanized гор.оцинк. HDZ
GMITR-10K D	0.720	100	1		10,08
GMITR-20K D	1.470	200	1		20,58
GMITR-30K D	2.380	300	1		33,32
GMITR-40K D	5.190	400	1,5		72,66
GMITR-50K D	7.020	500	1,5		98,28
GMITR-60K D	8.230	600	1,5		115,22

### Dörlü Bağlantı Kapakı Crossings Covers

Крестообразные соединительные элементы

Sipariş kodu Order code Код заявки	Ağırlık (Kg/ad.) Weight (Kg/unit) Вес (кг /шт)	A-B-C-D mm	e mm	Price list прайс-лист шт /у.е.	
				Pre-Galvanized Предв. Цинк-ия	Hot dip Galvanized гор.оцинк. HDZ
GMIDB-10K D	0.940	100	1		13,16
GMIDB-20K D	1.850	200	1		25,90
GMIDB-30K D	2.910	300	1		40,74
GMIDB-40K D	6.230	400	1,5		87,22
GMIDB-50K D	8.290	500	1,5		116,06
GMIDB-60K D	10.610	600	1,5		148,54

### İç Bükey Kapakı Inside Vertical Bend Cover

Внутри и снаружи Вертикального Покрытия Изгиба

Sipariş kodu Order code Код заявки	Ağırlık (Kg/ad.) Weight (Kg/unit) Вес (кг /шт)	A mm	e mm	Price list прайс-лист шт /у.е.	
				Pre-Galvanized Предв. Цинк-ия	Hot dip Galvanized гор.оцинк. HDZ
GMİIR-10K D	0,480	100	1		6,72
GMİIR-20K D	0,860	200	1		12,04
GMİIR-30K D	1,260	300	1		17,64
GMİIR-40K D	2,480	400	1,5		34,72
GMİIR-50K D	3,070	500	1,5		42,98
GMİIR-60K D	3,670	600	1,5		51,38

### Dış Bükey Kapakı Outside Vertical Bend Cover

Внутри и снаружи Вертикальных Изгибов

Sipariş kodu Order code Код заявки	Ağırlık (Kg/ad.) Weight (Kg/unit) Вес (кг /шт)	A mm	e mm	Price list прайс-лист шт /у.е.	
				Pre-Galvanized Предв. Цинк-ия	Hot dip Galvanized гор.оцинк. HDZ
GMİDR-10K D	0,480	100	1		6,72
GMİDR-20K D	0,860	200	1		12,04
GMİDR-30K D	1,260	300	1		17,64
GMİDR-40K D	2,480	400	1,5		34,72
GMİDR-50K D	3,070	500	1,5		42,98
GMİDR-60K D	3,670	600	1,5		51,38

### 135° Dönüş Eleman Kapakı 135° Flat Bend Element Cover

образные соединительные элементы

Sipariş kodu Order code Код заявки	Ağırlık (Kg/ad.) Weight (Kg/unit) Вес (кг /шт)	A-B mm	e mm	Price list прайс-лист шт /у.е.	
				Pre-Galvanized Предв. Цинк-ия	Hot dip Galvanized гор.оцинк. HDZ
GMIDR-10K-45 D	0,330	100	1		4,62
GMIDR-20K-45 D	0,900	200	1		12,60
GMIDR-30K-45 D	1,420	300	1		19,88
GMIDR-40K-45 D	2,350	400	1,5		32,90
GMIDR-50K-45 D	3,140	500	1,5		43,96
GMIDR-60K-45 D	4,050	600	1,5		56,70

Bağlantı eleman kapakları isteğe bağlı olarak 150-300-450-600-900 Radüslü imal edilir.  
Circler bend covers can be produced with 150-300-450-600-900 Radius.

KABLO KROŞESİ

Cable crochet

Крепления

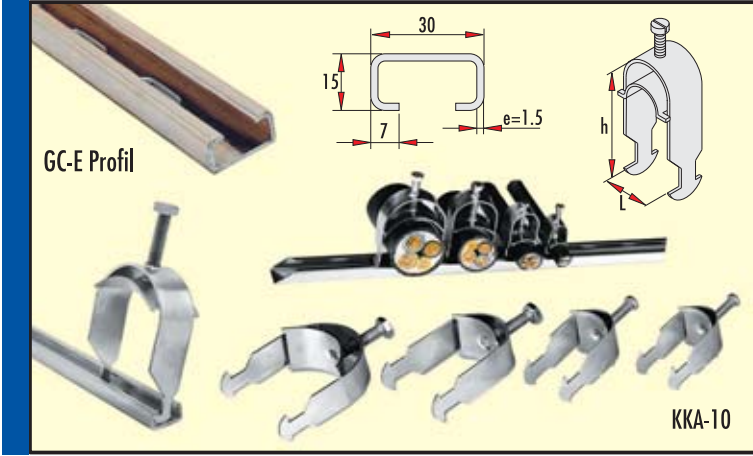

Sipariş kodu Order code Код заявки	Ağırlık (Kg/ad.) Weight (Kg/unit)	L mm	h mm	e mm	Kablo çapları Cable cross-section Сечения кабеля	Price list прайс-лист шт./у.е.
KKA-10 D	0,060	18	45	1,5	10-16	0,81
KKA-11 D	0,090	30	60	1,5	16-26	1,23
KKA-12 D	0,110	46	80	2	16-40	1,48
KKA-13 D	0,150	66	100	2	40-62	2,03

ANTİMANYETİK KROŞE (Cr-Ni)  
Antimagnetic crochet (Cr-Ni) Крепления

Sipariş kodu Order code Код заявки	Ağırlık (Kg/ad.) Weight (Kg/unit)	L mm	h mm	e mm	Price list прайс-лист шт./у.е.
KKA-10-P	0,060	18	45	1,5	1,94
KKA-11-P	0,090	30	60	1,5	2,90
KKA-12-P	0,110	46	80	2	3,55
KKA-13-P	0,150	66	100	2	4,84

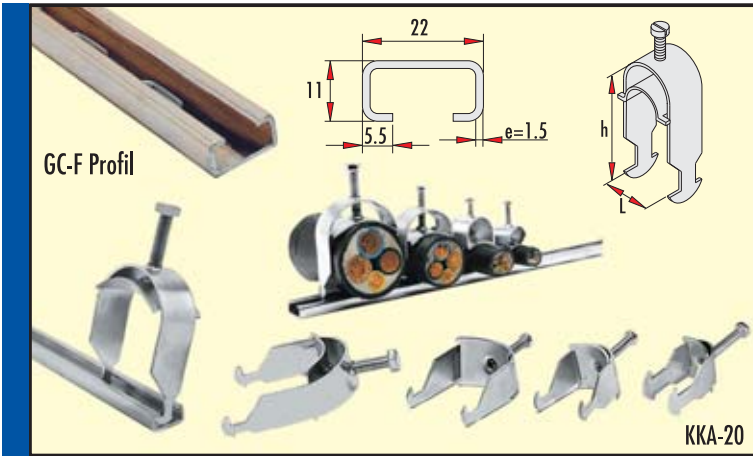

Sipariş kodu Order code Код заявки	Ağırlık (Kg/ad.) Weight (Kg/unit)	L mm	h mm	e mm	Kablo çapları Cable cross-section Сечения кабеля	Price list прайс-лист шт./у.е.
KKA-20 D	0,050	18	45	1,5	10-16	0,68
KKA-21 D	0,080	30	60	1,5	16-26	1,08
KKA-22 D	0,100	46	80	2	26-40	1,34
KKA-23 D	0,140	66	100	2	40-56	1,88

ANTİMANYETİK KROŞE (Cr-Ni)  
Antimagnetic crochet (Cr-Ni) Крепления

Sipariş kodu Order code Код заявки	Ağırlık (Kg/ad.) Weight (Kg/unit)	L mm	h mm	e mm	Price list прайс-лист шт./у.е.
KKA-20-P	0,050	18	45	1,5	1,61
KKA-21-P	0,080	30	60	1,5	2,58
KKA-22-P	0,100	46	80	2	3,23
KKA-23-P	0,140	66	100	2	4,52

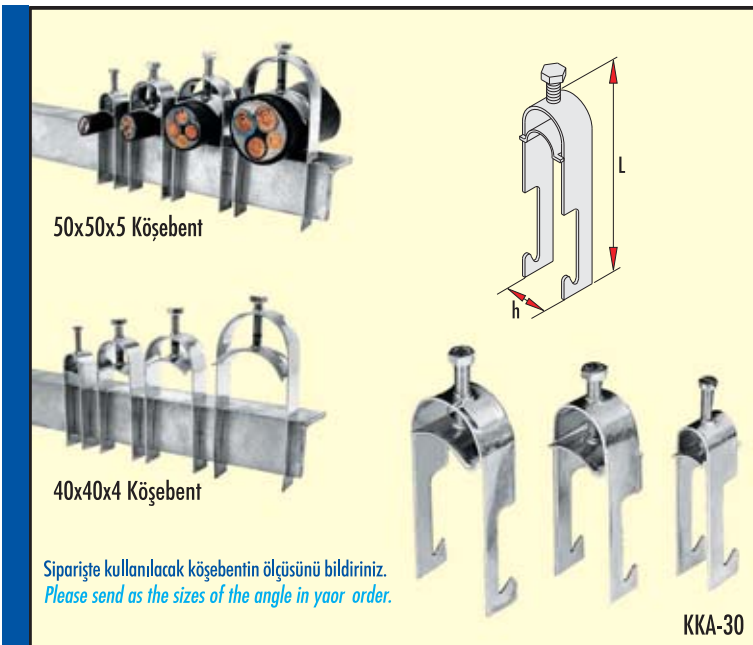

Sipariş kodu Order code Код заявки	Ağırlık (Kg/ad.) Weight (Kg/unit)	L mm	e mm	Kablo çapları Cable cross-section Сечения кабеля	Price list прайс-лист шт./у.е.
KKA-30 D	0,050	94	1,5	17,5	0,70
KKA-31 D	0,060	98	1,5	22	0,82
KKA-32 D	0,080	102	2	30	1,08
KKA-33 D	0,100	110	2	37	1,35
KKA-34 D	0,110	115	2	44	1,49
KKA-35 D	0,130	122	2	48	1,75
KKA-36 D	0,140	135	2	58	1,89
KKA-37 D	0,150	140	2	64	2,03
KKA-38 D	0,160	148	2	70	2,17

ANTİMANYETİK KROŞE (Cr-Ni)  
Antimagnetic crochet (Cr-Ni) Крепления

Sipariş kodu Order code Код заявки	Ağırlık (Kg/ad.) Weight (Kg/unit)	L mm	e mm	Price list прайс-лист шт./у.е.
KKA-30 P	0,050	94	1,5	1,61
KKA-31 P	0,060	98	1,5	1,94
KKA-32 P	0,080	102	2	2,58
KKA-33 P	0,100	110	2	3,23
KKA-34 P	0,110	115	2	3,55
KKA-35 P	0,130	122	2	4,19
KKA-36 P	0,140	135	2	4,52
KKA-37 P	0,150	140	2	4,84
KKA-38 P	0,160	148	2	5,16

KABLO KROŞESİ

Cable crochet

Крепления

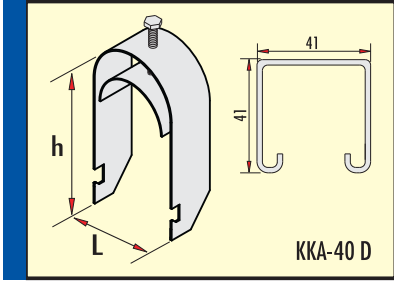

Sipariş kodu Order code Код заявки	Ağırlık (Kg/ad.) Weight (Kg/unit) Вес (кг/шт)	L mm	h mm	e mm	Price list прайс-лист шт/у.е.
KKA-40 D	0,080	18	70	2	1,08
KKA-41 D	0,120	30	82	2	1,61
KKA-42 D	0,145	46	90	2	1,96
KKA-43 D	0,180	66	102	2	2,42

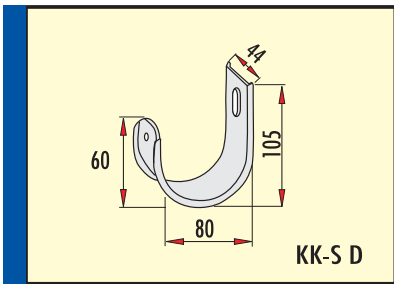
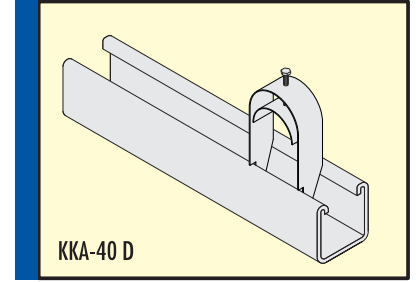

Sipariş kodu Order code Код заявки	Ağırlık (Kg/ad.) Weight (Kg/unit) Вес (кг/шт)	e mm	Price list прайс-лист шт/у.е.
KK-S-D	0,185	2	2.10
KK-SB D	0,260	2	2.80

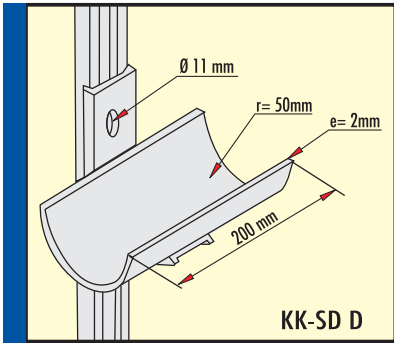
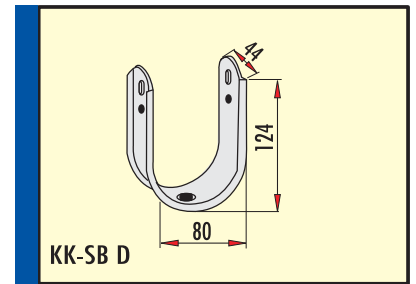

Sipariş kodu Order code Код заявки	Ağırlık (Kg/ad.) Weight (Kg/unit) Вес (кг/шт)	e mm	Price list прайс-лист шт/у.е.
KK-SD D	0.730	2	4.84
KK-P PLS	0.025	-	0.59

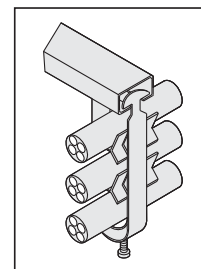
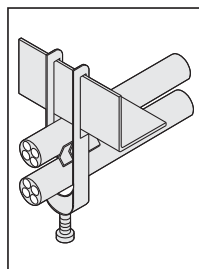
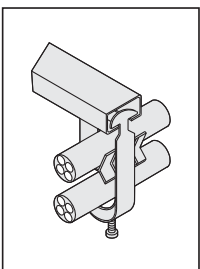
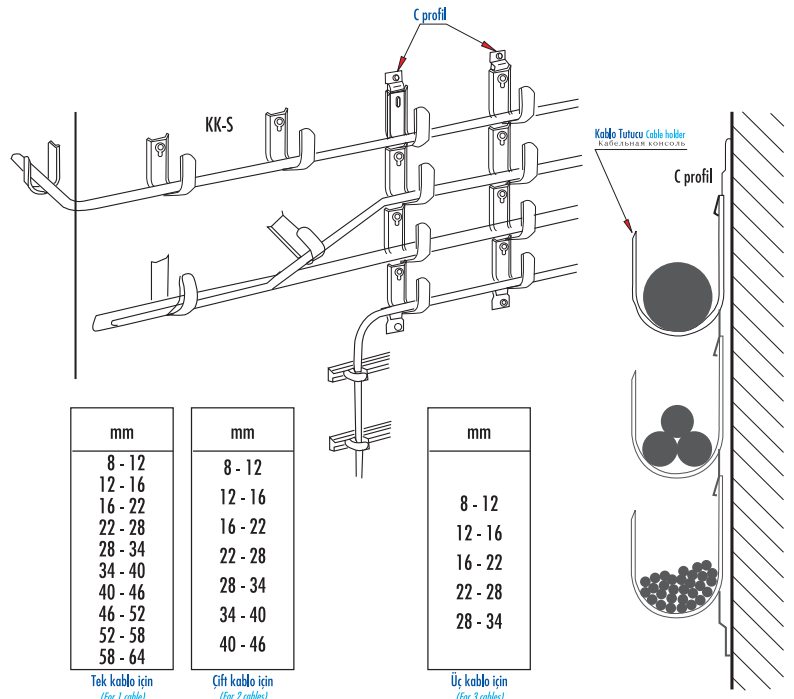
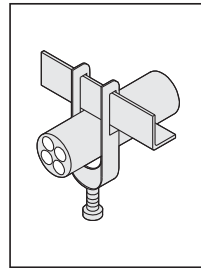
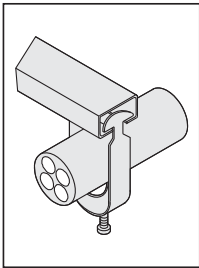
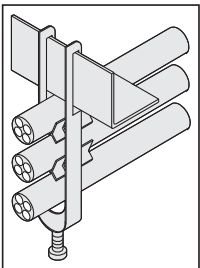
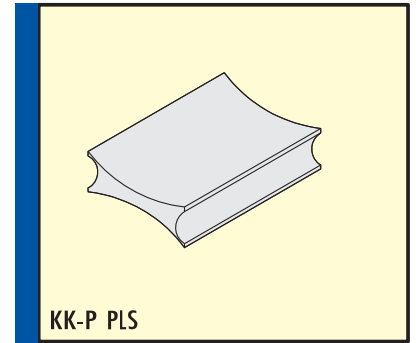

AĞIR HİZMET TİPİ KABLO MERDİVENLERİ

Heavy Duty Type Cable Ladders

Сверхмощные лестничные лотки

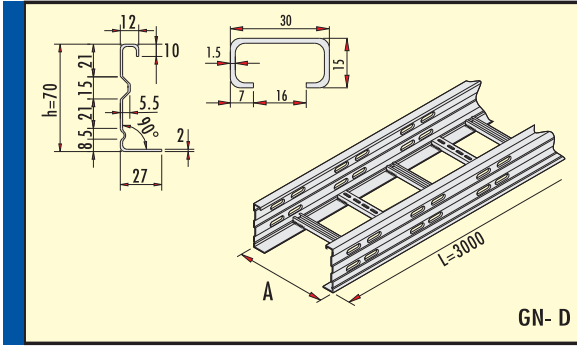

Ağır Hizmet Tipi Kablo Merdiveni  
Heavy Duty Type Cable Ladder

Сверхмощные лестничные лотки

Sipariş kodu Order code Код заявки	Ağırlık (Kg/mt.) Weight (Kg/mt) Вес (кг/м)	A mm	e mm	h mm	Price list прайс-лист М/у.е.
GN-20 D	3.900	200	2	70	39,00
GN-30 D	4.250	300	2	70	42,50
GN-40 D	4.550	400	2	70	45,50
GN-50 D	4.900	500	2	70	49,00
GN-60 D	5.150	600	2	70	51,50

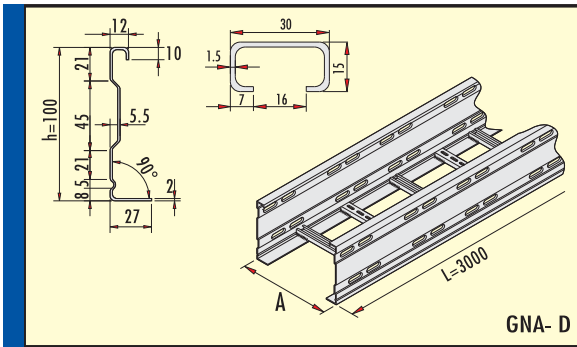

Ağır Hizmet Tipi Kablo Merdiveni  
Heavy Duty Type Cable Ladder

Сверхмощные лестничные лотки

Sipariş kodu Order code Код заявки	Ağırlık (Kg/mt.) Weight (Kg/mt) Вес (кг/м)	A mm	e mm	h mm	Price list прайс-лист М/у.е.
GNA-20 D	4.850	200	2	100	48,50
GNA-30 D	5.250	300	2	100	52,50
GNA-40 D	5.500	400	2	100	55,00
GNA-50 D	5.850	500	2	100	58,50
GNA-60 D	6.100	600	2	100	61,00

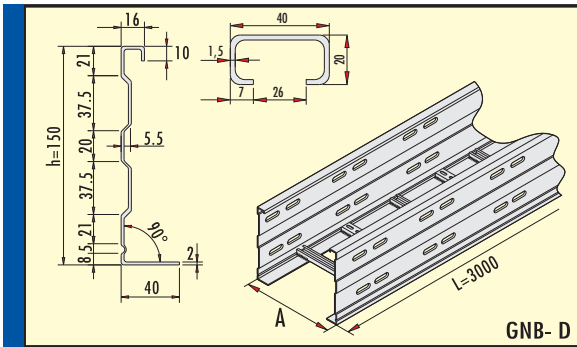

Ağır Hizmet Tipi Kablo Merdiveni  
Heavy Duty Type Cable Ladder

Сверхмощные лестничные лотки

Sipariş kodu Order code Код заявки	Ağırlık (Kg/mt.) Weight (Kg/mt) Вес (кг/м)	A mm	e mm	h mm	Price list прайс-лист М/у.е.
GNB-20 D	7.750	200	2	150	77,50
GNB-30 D	8.150	300	2	150	81,50
GNB-40 D	8.450	400	2	150	84,50
GNB-50 D	8.750	500	2	150	87,50
GNB-60 D	9.000	600	2	150	90,00

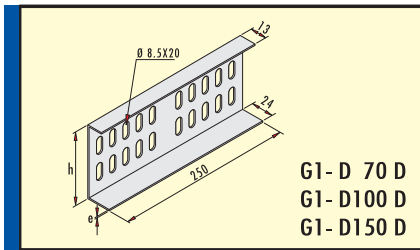

G1- D 70 D  
G1- D 100 D  
G1- D 150 D

Ek Parçası Jointing Piece

Соединительные элементы

Sipariş kodu Order code Код заявки	Ağırlık (Kg/ad.) Weight (Kg/unit) Вес (кг/шт)	e mm	h mm	Price list прайс-лист шт/у.е.
G1- D 70 D	0,400	2	76	5,60
G1- D 100 D	0,550	2	106	7,70
G1- D 150 D	0,750	2	156	10,50

En yüksek taşıma kapasitesi (Equal distance Support)  
Устанавливать на равных промежутках

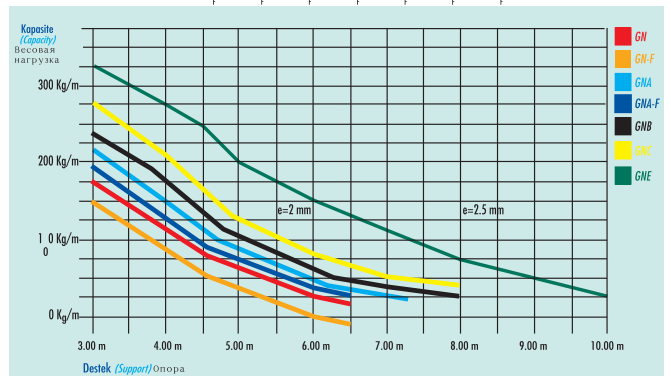

Kaplama : TS 914 EN ISO-1461 (BS-EN-ISO-1461) Sıcak Daldırma Galvaniz. Coating : TS 914 EN ISO-1461 (BS-EN-ISO-1461) Hot Dip Galvanized

Talep üzerine tüm ürünler RODINO 50® malzemesi ile kaplanarak (max) 400°C ısıya, asit, tuz ve kum etkilerine karşı mukavemet sağlar.

In case of required all type of materials can be coated with RODINO 50® which will give on extra resistant at effect of 400°C heat, acid, salt and sand for the material.



## AĞIR HİZMET TİPİ KABLO MERDİVENLERİ

## Heavy Duty Type Cable Ladders

Сверхмощные лестничные лотки

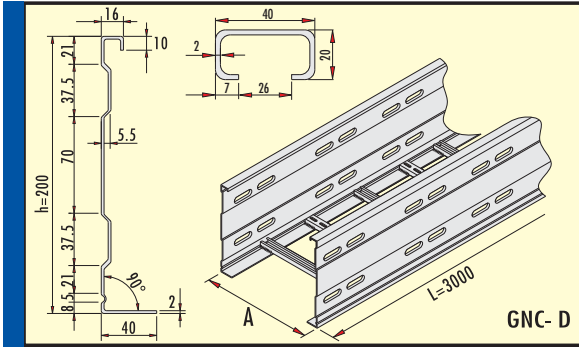

### Ağır Hizmet Tipi Kablo Merdiveni Heavy Duty Type Cable Ladder Сверхмощные лестничные лотки

Sipariş kodu Order code Код заявки	Ağırlık (Kg/mt.) Weight (Kg/mt) Вес (кг/м)	A mm	e mm	h mm	Price list прайс-лист м/у.е.
GNC-20 D	9,750	200	2	200	97,50
GNC-30 D	10,150	300	2	200	101,50
GNC-40 D	10,450	400	2	200	104,50
GNC-50 D	10,750	500	2	200	107,50
GNC-60 D	11,000	600	2	200	110,00

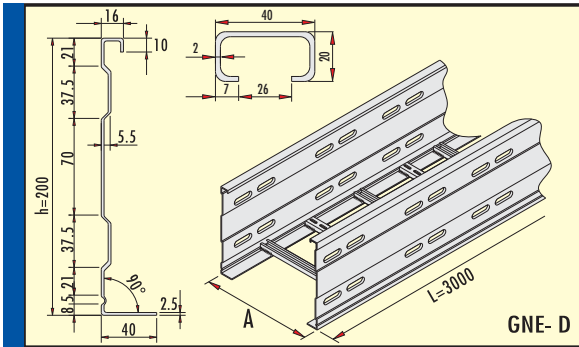

### Ağır Hizmet Tipi Kablo Merdiveni Heavy Duty Type Cable Ladder Сверхмощные лестничные лотки

Sipariş kodu Order code Код заявки	Ağırlık (Kg/mt.) Weight (Kg/mt) Вес (кг/м)	A mm	e mm	h mm	Price list прайс-лист м/у.е.
GNE-20 D	12.250	200	2,5	200	112,50
GNE-30 D	12.800	300	2,5	200	128,50
GNE-40 D	13.150	400	2,5	200	131,50
GNE-50 D	13.600	500	2,5	200	136,00
GNE-60 D	13.900	600	2,5	200	139,00

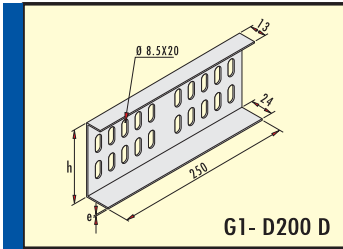

### Ek Parçası Jointing Piece Соединительные элементы

Sipariş kodu Order code Код заявки	Ağırlık (Kg/ad.) Weight (Kg/unit) Вес (кг/шт)	e mm	h mm	Price list прайс-лист шт/у.е.
G1 - D 200 D	0,950	2	206	13,30

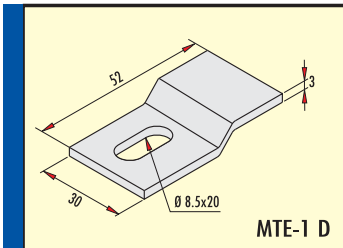
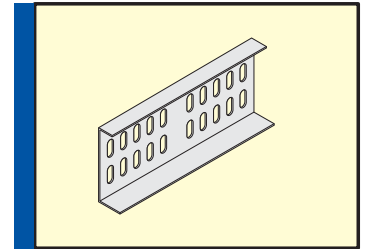

### Merdiven Duvara ve Konsola Tespit Elemanı Ladder Fixing unit For Wall and Bracket

элементы крепления лестницы к стене и к консоли

Sipariş kodu Order code Код заявки	Ağırlık (Kg/ad.) Weight (Kg/unit) Вес (кг/шт)	e mm	Price list прайс-лист шт/у.е.
MTE -1 D	0,037	3	0,75

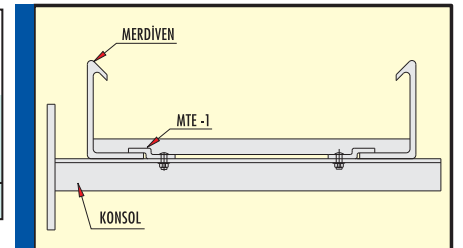

Kaplama : TS 914 EN ISO-1461 (BS-EN-ISO-1461) Sıcak Daldırma Galvaniz. Coating : TS 914 EN ISO-1461 (BS-EN-ISO-1461) Hot Dip Galvanized

L= Standart boylar 3000 mm'dir. İstek üzerine 6000 mm üretilir. L= Standart length is 30000 mm. 6000 mm length can be produced due to request.

L= стандартная длина 3000 мм. При необходимости могут быть изготовлены в размере 6000 мм согласно заказа.

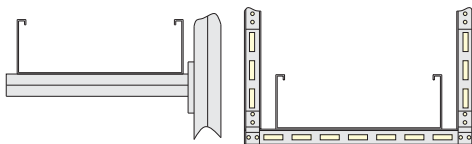

Bu tip kanalların 125 kg/m yükten sonra çift taraflı askıya alınması tavsiye edilir.

These type of ladders are recommended to be mounted

from two sides for loads more than 125 kg/m.

Эти типы лестничных лотков рекомендуется монтировать

с двух сторон несущих частей свыше 125 кг/м.

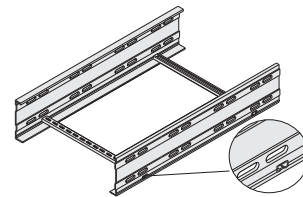

İstek üzerine basamaklar merdiven profiline yukarıdaki şekildeki gibi yan delikler açılarak kaynaklanabilir.

Rungs could be placed and welded through the holes perforated on the side of the ladder as seen on the figure above.

Звенья могут быть расположены и приварены через перфорированные отверстия на поверхности лестнице, как показано выше на рисунке.

Talep üzerine tüm ürünler RODINO 50® malzemesi ile kaplanarak (max) 400°C ısıya, asit, tuz ve kum etkilerine karşı mukavemet sağlar.

In case of required all type of materials can be coated with RODINO 50® which will give an extra resistant at effect of 400°C heat, acid, salt and sand for the material.

90° DÖNÜŞ ELEMANLARI

угловые элементы 90°

90° Flat Bends

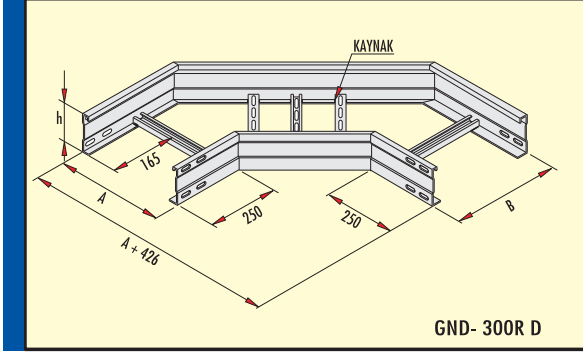

90° Dönüş Elemanı 300 Radüs 90° Flat Bend Radius 300  
угловые элементы 90° (Радиус 300)

Sipariş kodu Order code Код заявки	Ağırlık (Kg/ad.) Weight (Kg/unit) Вес (кг/шт)	A-B mm	e mm	h mm	Price list прайс-лист шт./y.e.	
					Pre-Galvanized Предв. Цинк-ия	Hot dip Galvanized гор.оцинк. HDZ
GND-20 300R D	3,900	200	2	70		54,60
GND-30 300R D	4,550	300	2	70		63,70
GND-40 300R D	5,200	400	2	70		72,80
GND-50 300R D	5,850	500	2	70		81,90
GND-60 300R D	6,550	600	2	70		91,70
GND-A20 300R D	4,750	200	2	100		66,50
GND-A30 300R D	5,500	300	2	100		77,00
GND-A40 300R D	6,250	400	2	100		87,50
GND-A50 300R D	7,000	500	2	100		98,00
GND-A60 300R D	7,700	600	2	100		107,80
GND-B20 300R D	7,400	200	2	150		103,60
GND-B30 300R D	8,400	300	2	150		117,60
GND-B40 300R D	9,400	400	2	150		131,60
GND-B50 300R D	10,300	500	2	150		144,20
GND-B60 300R D	11,350	600	2	150		158,90
GND-C20 300R D	9,300	200	2	200		130,20
GND-C30 300R D	10,450	300	2	200		146,30
GND-C40 300R D	11,550	400	2	200		161,70
GND-C50 300R D	12,700	500	2	200		177,80
GND-C60 300R D	13,850	600	2	200		193,90

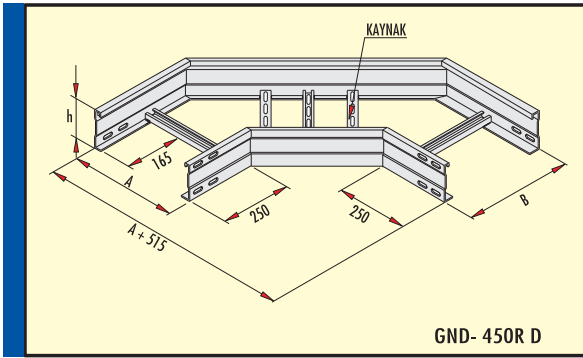

90° Dönüş Elemanı 450 Radüs 90° Flat Bend Radius 450

угловые элементы 90° (Радиус 450)

Sipariş kodu Order code Код заявки	Ağırlık (Kg/ad.) Weight (Kg/unit) Вес (кг/шт)	A-B mm	e mm	h mm	Price list прайс-лист шт./y.e.	
					Pre-Galvanized Предв. Цинк-ия	Hot dip Galvanized гор.оцинк. HDZ
GND-20 450R D	4,330	200	2	70		60,62
GND-30 450R D	4,950	300	2	70		69,30
GND-40 450R D	5,650	400	2	70		79,10
GND-50 450R D	6,250	500	2	70		87,50
GND-60 450R D	6,950	600	2	70		97,30
GND-A20 450R D	5,300	200	2	100		74,20
GND-A30 450R D	6,050	300	2	100		84,70
GND-A40 450R D	6,800	400	2	100		95,20
GND-A50 450R D	7,500	500	2	100		105,00
GND-A60 450R D	8,200	600	2	100		114,80
GND-B20 450R D	8,300	200	2	150		116,20
GND-B30 450R D	9,300	300	2	150		130,20
GND-B40 450R D	10,300	400	2	150		144,20
GND-B50 450R D	11,300	500	2	150		158,20
GND-B60 450R D	12,300	600	2	150		172,20
GND-C20 450R D	10,450	200	2	200		146,30
GND-C30 450R D	11,550	300	2	200		161,70
GND-C40 450R D	12,550	400	2	200		175,70
GND-C50 450R D	13,550	500	2	200		189,70
GND-C60 450R D	14,550	600	2	200		203,70

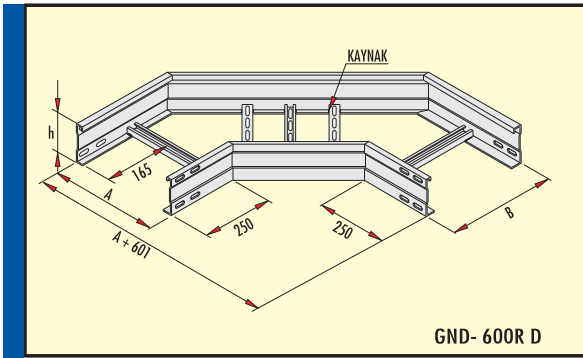

90° Dönüş Elemanı 600 Radüs 90° Flat Bend Radius 600

угловые элементы 90° (Радиус 600)

Sipariş kodu Order code Код заявки	Ağırlık (Kg/ad.) Weight (Kg/unit) Вес (кг/шт)	A-B mm	e mm	h mm	Price list прайс-лист шт./y.e.	
					Pre-Galvanized Предв. Цинк-ия	Hot dip Galvanized гор.оцинк. HDZ
GND-20 600R D	4,850	200	2	70		67,90
GND-30 600R D	5,450	300	2	70		76,30
GND-40 600R D	6,050	400	2	70		84,70
GND-50 600R D	6,650	500	2	70		93,10
GND-60 600R D	7,250	600	2	70		101,50
GND-A20 600R D	6,050	200	2	100		84,70
GND-A30 600R D	6,700	300	2	100		93,80
GND-A40 600R D	7,350	400	2	100		102,90
GND-A50 600R D	8,050	500	2	100		112,70
GND-A60 600R D	8,700	600	2	100		121,80
GND-B20 600R D	9,400	200	2	150		131,60
GND-B30 600R D	10,300	300	2	150		144,20
GND-B40 600R D	11,200	400	2	150		156,80
GND-B50 600R D	12,100	500	2	150		169,40
GND-B60 600R D	13,000	600	2	150		182,00
GND-C20 600R D	11,700	200	2	200		163,80
GND-C30 600R D	12,800	300	2	200		179,20
GND-C40 600R D	13,800	400	2	200		193,20
GND-C50 600R D	14,900	500	2	200		208,60
GND-C60 600R D	15,900	600	2	200		222,60

Kaplama : TS 914 EN ISO-1461 (BS-EN-ISO-1461) Sıcak Daldırma Galvaniz.

Coating : TS 914 EN ISO-1461 (BS-EN-ISO-1461) Hot Dip Galvanized

Talep üzerine tüm ürünler RODINO 50® malzemesi ile kaplanarak (max) 400°C ısıya, asit, tuz ve kum etkilerine karşı mukavemet sağlar.

In case of required all type of materials can be coated with RODINO 50® which will give on extra resistant at effect of 400°C heat, acid, salt and sand for the material.

90° DÖNÜŞ ELEMANI KAPAKLARI

90° Flat Bend Covers

90° Плоских Покрывтий Изгиба

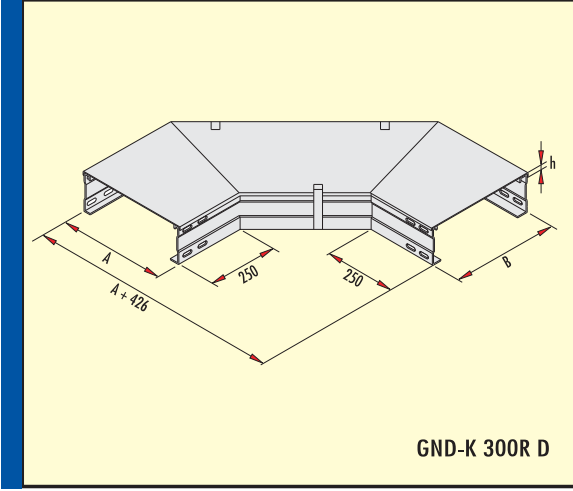

90° Dönüş Eleman Kapığı 300 Radüs

90° Flat Bend Cover Radius 300

90° Плоских Радиусов Покрывтия Изгиба 300

Sipariş kodu Order code Код заявки	Ağırlık (Kg/ad.) Weight (Kg/unit) Вес (кг/шт)	A-B mm	e mm	h mm	Price list прайс-лист шт/у.е.	
					Pre-Galvanized Предв. Цинк-ия	Hot dip Galvanized гор.оцинк. HDZ
GND-20K 300R D	1,750	200	1	9		24,50
GND-30K 300R D	2,750	300	1	9		38,50
GND-40K 300R D	6,100	400	1.5	9		85,40
GND-50K 300R D	8,250	500	1.5	9		115,50
GND-60K 300R D	10,500	600	1.5	9		147,00

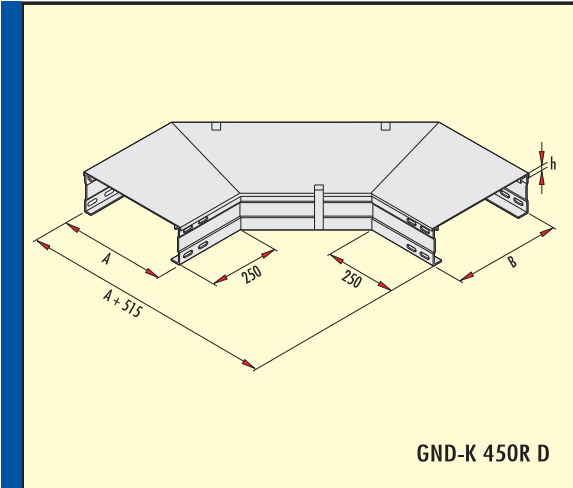

90° Dönüş Eleman Kapığı 450 Radüs

90° Flat Bend Cover Radius 450

90° Плоских Радиусов Покывтия Изгиба 450

Sipariş kodu Order code Код заявки	Ağırlık (Kg/ad.) Weight (Kg/unit) Вес (кг/шт)	A-B mm	e mm	h mm	Price list прайс-лист шт/у.е.	
					Pre-Galvanized Предв. Цинк-ия	Hot dip Galvanized гор.оцинк. HDZ
GND-20K 450R D	2,000	200	1	9		28,00
GND-30K 450R D	3,050	300	1	9		42,70
GND-40K 450R D	6,700	400	1.5	9		93,80
GND-50K 450R D	8,900	500	1.5	9		124,60
GND-60K 450R D	11,350	600	1.5	9		158,90

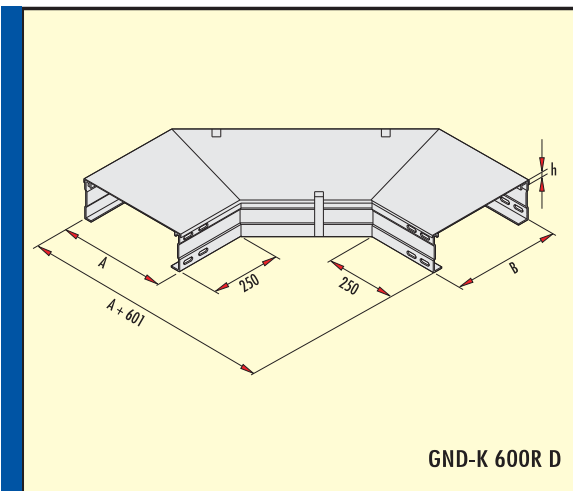

90° Dönüş Eleman Kapığı 600 Radüs

90° Flat Bend Cover Radius 600

90° Плоских Радиусов Покывтия Изгиба 600

Sipariş kodu Order code Код заявки	Ağırlık (Kg/ad.) Weight (Kg/unit) Вес (кг/шт)	A-B mm	e mm	h mm	Price list прайс-лист шт/у.е.	
					Pre-Galvanized Предв. Цинк-ия	Hot dip Galvanized гор.оцинк. HDZ
GND-20K 600R D	2,150	200	1	9		30,10
GND-30K 600R D	3,450	300	1	9		48,30
GND-40K 600R D	7,350	400	1.5	9		102,90
GND-50K 600R D	9,800	500	1.5	9		137,20
GND-60K 600R D	12,500	600	1.5	9		175,00

Kaplama : TS 914 EN ISO-1461 (BS-EN-ISO-1461) Sıcak Daldırma Galvaniz. Coating : TS 914 EN ISO-1461 (BS-EN-ISO-1461) Hot Dip Galvanized

Talep üzerine tüm ürünler RODINO 50® malzemesi ile kaplanarak (max) 400°C ısıya, asit, tuz ve kum etkilerine karşı mukavemet sağlar.

In case of required all type of materials can be coated with RODINO 50® which will give on extra resistant at effect of 400°C heat, acid, salt and sand for the material.

“T” BAĞLANTI ELEMANLARI Tee “T” Elements

«T» образные соединительные элементы

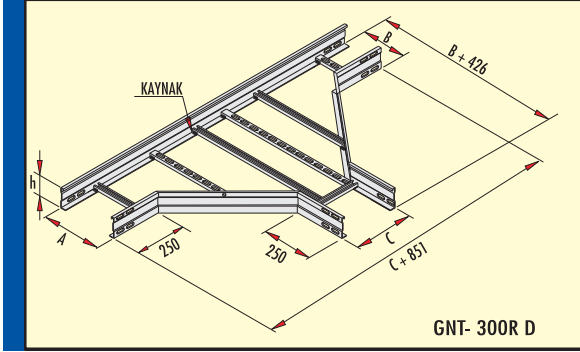

“T” Bağlantı Elemanı 300 Radius Tee “T” Element Radius 300

«T» образные соединительные элементы (Радиус 300)

Sipariş kodu Order code Код заявки	Ağırlık (Kg/ad.) Weight (Kg/unit) Вес (кг/шт)	A-B-C mm	e mm	h mm	Price list прайс-лист шт/у.е.	
					Pre-Galvanized Предв. Цинк-ия	Hot dip Galvanized гор.оцинк. HDZ
GNT-20 300R D	5,850	200	2	70		81,90
GNT-30 300R D	6,500	300	2	70		91,00
GNT-40 300R D	7,100	400	2	70		99,40
GNT-50 300R D	7,800	500	2	70		109,20
GNT-60 300R D	8,400	600	2	70		117,60
GNT-A20 300R D	7,050	200	2	100		98,70
GNT-A30 300R D	7,800	300	2	100		109,20
GNT-A40 300R D	8,550	400	2	100		119,70
GNT-A50 300R D	9,300	500	2	100		130,20
GNT-A60 300R D	10,050	600	2	100		140,70
GNT-B20 300R D	9,800	200	2	150		137,20
GNT-B30 300R D	11,500	300	2	150		161,00
GNT-B40 300R D	13,300	400	2	150		186,20
GNT-B50 300R D	15,100	500	2	150		211,40
GNT-B60 300R D	16,800	600	2	150		235,20
GNT-C20 300R D	13,350	200	2	200		186,90
GNT-C30 300R D	14,300	300	2	200		200,20
GNT-C40 300R D	15,300	400	2	200		214,20
GNT-C50 300R D	16,300	500	2	200		228,20
GNT-C60 300R D	17,300	600	2	200		242,20

“T” Bağlantı Elemanı 450 Radius Tee “T” Element Radius 450

«T» образные соединительные элементы (Радиус 450)

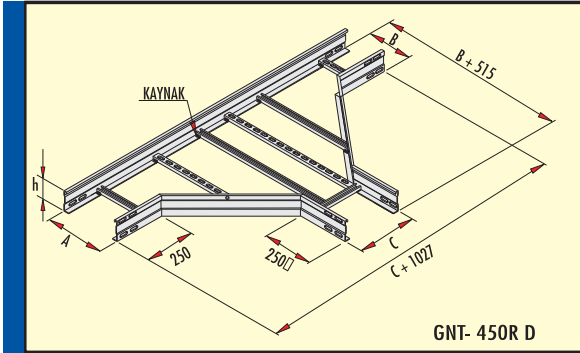

Sipariş kodu Order code Код заявки	Ağırlık (Kg/ad.) Weight (Kg/unit) Вес (кг/шт)	A-B-C mm	e mm	h mm	Price list прайс-лист шт/у.е.	
					Pre-Galvanized Предв. Цинк-ия	Hot dip Galvanized гор.оцинк. HDZ
GNT-20 450R D	6,500	200	2	70		91,00
GNT-30 450R D	7,250	300	2	70		101,50
GNT-40 450R D	8,000	400	2	70		112,00
GNT-50 450R D	8,750	500	2	70		122,50
GNT-60 450R D	9,500	600	2	70		133,00
GNT-A20 450R D	8,000	200	2	100		112,00
GNT-A30 450R D	8,750	300	2	100		122,50
GNT-A40 450R D	9,500	400	2	100		133,00
GNT-A50 450R D	10,250	500	2	100		143,50
GNT-A60 450R D	11,000	600	2	100		154,00
GNT-B20 450R D	12,300	200	2	150		172,20
GNT-B30 450R D	13,050	300	2	150		182,70
GNT-B40 450R D	13,800	400	2	150		193,20
GNT-B50 450R D	14,550	500	2	150		203,70
GNT-B60 450R D	15,300	600	2	150		214,20
GNT-C20 450R D	14,300	200	2	200		200,20
GNT-C30 450R D	16,050	300	2	200		224,70
GNT-C40 450R D	16,800	400	2	200		235,20
GNT-C50 450R D	17,550	500	2	200		245,70
GNT-C60 450R D	18,300	600	2	200		256,20

“T” Bağlantı Elemanı 600 Radius Tee “T” Element Radius 600

«T» образные соединительные элементы (Радиус 600)

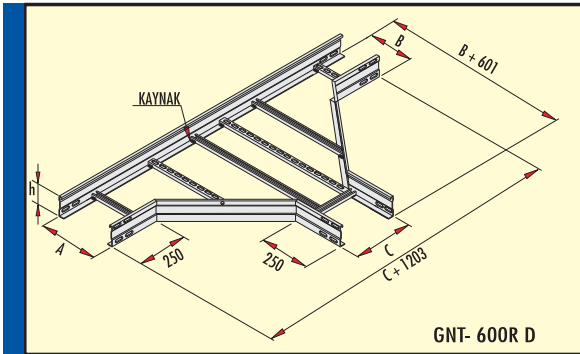

Sipariş kodu Order code Код заявки	Ağırlık (Kg/ad.) Weight (Kg/unit) Вес (кг/шт)	A-B-C mm	e mm	h mm	Price list прайс-лист шт/у.е.	
					Pre-Galvanized Предв. Цинк-ия	Hot dip Galvanized гор.оцинк. HDZ
GNT-20 600R D	7,500	200	2	70		105,00
GNT-30 600R D	8,200	300	2	70		114,80
GNT-40 600R D	8,900	400	2	70		124,60
GNT-50 600R D	9,600	500	2	70		134,40
GNT-60 600R D	10,300	600	2	70		144,20
GNT-A20 600R D	9,200	200	2	100		128,80
GNT-A30 600R D	9,950	300	2	100		139,30
GNT-A40 600R D	10,700	400	2	100		149,80
GNT-A50 600R D	11,450	500	2	100		160,30
GNT-A60 600R D	12,200	600	2	100		170,80
GNT-B20 600R D	14,200	200	2	150		198,80
GNT-B30 600R D	14,950	300	2	150		209,30
GNT-B40 600R D	15,700	400	2	150		219,80
GNT-B50 600R D	16,450	500	2	150		230,30
GNT-B60 600R D	17,200	600	2	150		240,80
GNT-C20 600R D	17,600	200	2	200		246,40
GNT-C30 600R D	18,650	300	2	200		261,10
GNT-C40 600R D	19,700	400	2	200		275,80
GNT-C50 600R D	20,750	500	2	200		290,50
GNT-C60 600R D	21,800	600	2	200		305,20

Kaplama : TS 914 EN ISO-1461 (BS-EN-ISO-1461) Sıcak Daldırma Galvaniz.  
Coating : TS 914 EN ISO-1461 (BS-EN-ISO-1461) Hot Dip Galvanized

Talep üzerine tüm ürünler RODINO 50® malzemesi ile kaplanarak (max) 400°C ısıya, asit, tuz ve kum etkilerine karşı mukavemet sağlar.  
In case of required all type of materials can be coated with RODINO 50® which will give on extra resistant at effect of 400°C heat, acid, salt and sand for the material.



"T" BAĞLANTI ELEMANI KAPAKLARI

Tee "T" Element Covers

Мишень "Т" Покрытия Элемента

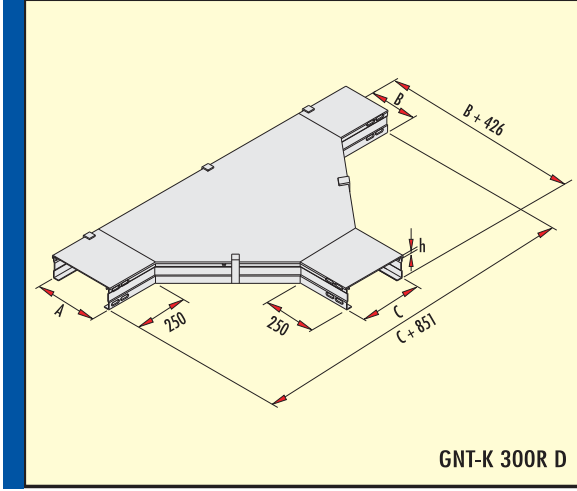

"T" Bağlantı Eleman Kapakı 300 Radius

Tee "T" Element Cover Radius 300

Мишень "Т" Радиус Покрытия Элемента 300

Sipariş kodu Order code Код заявки	Ağırlık (Kg/ad.) Weight (Kg/unit) Вес (кг/шт)	A-B-C mm	e mm	h mm	Price list прайс-лист шт/у.е.	
					Pre-Galvanized Предв. Цинк-ия	Hot dip Galvanized гор.оцинк. HDZ
GNT-20K 300R D	3,050	200	1	9		42,70
GNT-30K 300R D	4,650	300	1	9		65,10
GNT-40K 300R D	9,900	400	1.5	9		138,60
GNT-50K 300R D	12,700	500	1.5	9		177,80
GNT-60K 300R D	16,000	600	1.5	9		224,00

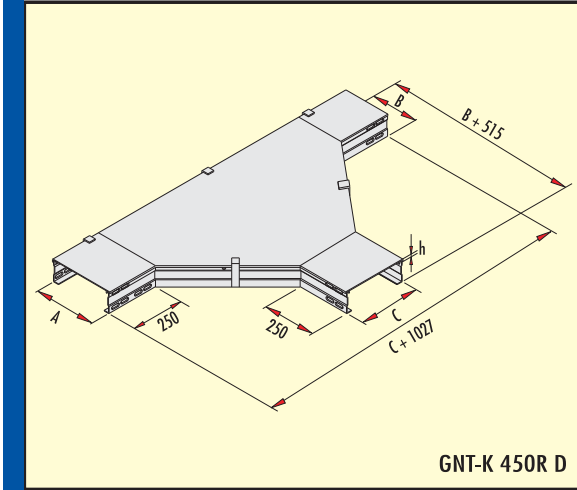

"T" Bağlantı Eleman Kapakı 450 Radius

Tee "T" Element Cover Radius 450

Мишень "Т" Радиус Покрытия Элемента 450

Sipariş kodu Order code Код заявки	Ağırlık (Kg/ad.) Weight (Kg/unit) Вес (кг/шт)	A-B-C mm	e mm	h mm	Price list прайс-лист шт/у.е.	
					Pre-Galvanized Предв. Цинк-ия	Hot dip Galvanized гор.оцинк. HDZ
GNT-20K 450R D	3,900	200	1	9		54,60
GNT-30K 450R D	5,750	300	1	9		80,50
GNT-40K 450R D	11,700	400	1.5	9		163,80
GNT-50K 450R D	15,050	500	1.5	9		210,70
GNT-60K 450R D	18,700	600	1.5	9		261,80

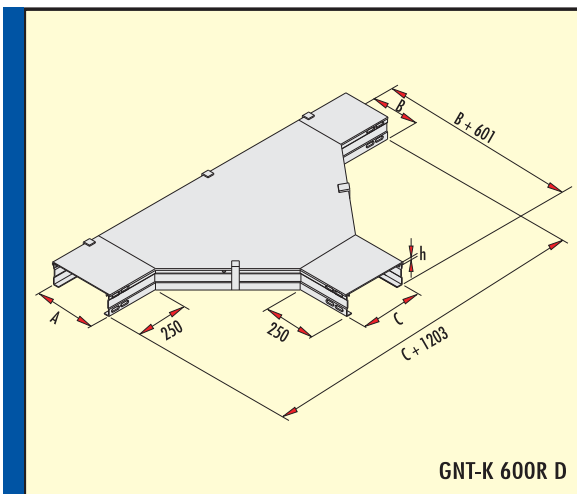

"T" Bağlantı Eleman Kapakı 600 Radius

Tee "T" Element Cover Radius 600

Мишень "Т" Радиус Покрытия Элемента 600

Sipariş kodu Order code Код заявки	Ağırlık (Kg/ad.) Weight (Kg/unit) Вес (кг/шт)	A-B-C mm	e mm	h mm	Price list прайс-лист шт/у.е.	
					Pre-Galvanized Предв. Цинк-ия	Hot dip Galvanized гор.оцинк. HDZ
GNT-20K 600R D	4,000	200	1	9		56,00
GNT-30K 600R D	7,000	300	1	9		98,00
GNT-40K 600R D	14,000	400	1.5	9		196,00
GNT-50K 600R D	17,650	500	1.5	9		247,10
GNT-60K 600R D	21,700	600	1.5	9		303,80

Kaplama : TS 914 EN ISO-1461 (BS-EN-ISO-1461) Sıcak Daldırma Galvaniz. Coating : TS 914 EN ISO-1461 (BS-EN-ISO-1461) Hot Dip Galvanized

Talep üzerine tüm ürünler RODINO 50® malzemesi ile kaplanarak (max) 400°C ısıya, asit, tuz ve kum etkilerine karşı mukavemet sağlar.

In case of required all type of materials can be coated with RODINO 50® which will give an extra resistant at effect of 400°C heat, acid, salt and sand for the material.

**DÖRTLÜ BAĞLANTI ELEMANLARI** *Crossing Elements*  
Пересечение Элементов

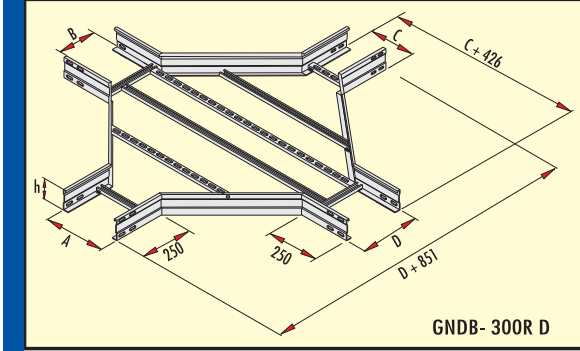

Dörtlü Bağlantı Elemanı 300 Radius Crossing Element Radius 300  
Пересечение Элементов (Радиус 300)

Sipariş kodu Order code Код заявки	Ağırlık (Kg/ad.) Weight (Kg/unit) Вес (кг /шт)	A-B-C-D mm	e mm	h mm	Price list прайс-лист шт./у.е.	
					Pre-Galvanized Предв. Цинк-ия	Hot dip Galvanized гор.оцинк. HDZ
GNDB-20 300R D	7,100	200	2	70		99,40
GNDB-30 300R D	7,600	300	2	70		106,40
GNDB-40 300R D	8,100	400	2	70		113,40
GNDB-50 300R D	8,600	500	2	70		120,40
GNDB-60 300R D	9,100	600	2	70		127,40
GNDB-A20 300R D	8,500	200	2	100		119,00
GNDB-A30 300R D	9,000	300	2	100		126,00
GNDB-A40 300R D	9,500	400	2	100		133,00
GNDB-A50 300R D	10,000	500	2	100		140,00
GNDB-A60 300R D	10,500	600	2	100		147,00
GNDB-B20 300R D	13,000	200	2	150		182,00
GNDB-B30 300R D	13,500	300	2	150		189,00
GNDB-B40 300R D	14,000	400	2	150		196,00
GNDB-B50 300R D	14,500	500	2	150		203,00
GNDB-B60 300R D	15,000	600	2	150		210,00
GNDB-C20 300R D	16,000	200	2	200		224,00
GNDB-C30 300R D	16,500	300	2	200		231,00
GNDB-C40 300R D	17,000	400	2	200		238,00
GNDB-C50 300R D	17,500	500	2	200		245,00
GNDB-C60 300R D	18,000	600	2	200		252,00

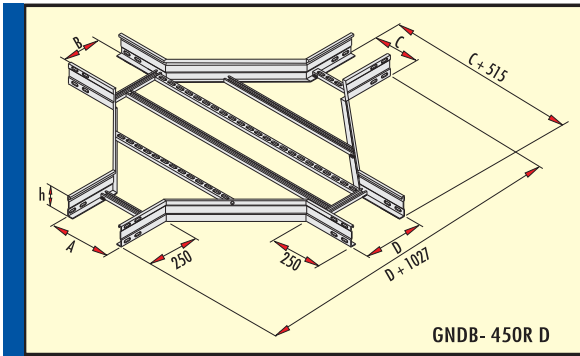

Dörtlü Bağlantı Elemanı 450 Radius Crossing Element Radius 450  
Пересечение Элементов (Радиус 450)

Sipariş kodu Order code Код заявки	Ağırlık (Kg/ad.) Weight (Kg/unit) Вес (кг /шт)	A-B-C-D mm	e mm	h mm	Price list прайс-лист шт./у.е.	
					Pre-Galvanized Предв. Цинк-ия	Hot dip Galvanized гор.оцинк. HDZ
GNDB-20 450R D	8,450	200	2	70		118,30
GNDB-30 450R D	9,000	300	2	70		126,00
GNDB-40 450R D	9,550	400	2	70		133,70
GNDB-50 450R D	10,100	500	2	70		141,40
GNDB-60 450R D	10,650	600	2	70		149,10
GNDB-A20 450R D	9,200	200	2	100		128,80
GNDB-A30 450R D	9,700	300	2	100		135,80
GNDB-A40 450R D	10,200	400	2	100		142,80
GNDB-A50 450R D	10,700	500	2	100		149,80
GNDB-A60 450R D	11,200	600	2	100		156,80
GNDB-B20 450R D	13,700	200	2	150		191,80
GNDB-B30 450R D	14,200	300	2	150		198,80
GNDB-B40 450R D	14,700	400	2	150		205,80
GNDB-B50 450R D	15,200	500	2	150		212,80
GNDB-B60 450R D	15,700	600	2	150		219,80
GNDB-C20 450R D	17,000	200	2	200		238,00
GNDB-C30 450R D	17,500	300	2	200		245,00
GNDB-C40 450R D	18,200	400	2	200		254,80
GNDB-C50 450R D	18,700	500	2	200		261,80
GNDB-C60 450R D	19,200	600	2	200		268,80

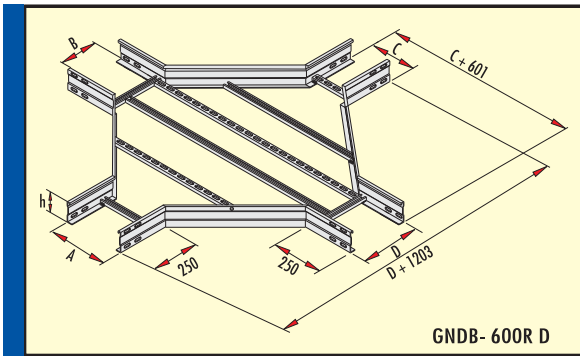

Dörtlü Bağlantı Elemanı 600 Radius Crossing Element Radius 600  
Пересечение Элементов (Радиус 600)

Sipariş kodu Order code Код заявки	Ağırlık (Kg/ad.) Weight (Kg/unit) Вес (кг /шт)	A-B-C-D mm	e mm	h mm	Price list прайс-лист шт./у.е.	
					Pre-Galvanized Предв. Цинк-ия	Hot dip Galvanized гор.оцинк. HDZ
GNDB-20 600R D	9,700	200	2	70		135,80
GNDB-30 600R D	10,200	300	2	70		142,80
GNDB-40 600R D	10,700	400	2	70		149,80
GNDB-50 600R D	11,200	500	2	70		156,80
GNDB-60 600R D	11,700	600	2	70		163,80
GNDB-A20 600R D	10,700	200	2	100		149,80
GNDB-A30 600R D	12,200	300	2	100		170,80
GNDB-A40 600R D	12,700	400	2	100		177,80
GNDB-A50 600R D	13,200	500	2	100		184,80
GNDB-A60 600R D	13,700	600	2	100		191,80
GNDB-B20 600R D	17,500	200	2	150		245,00
GNDB-B30 600R D	18,200	300	2	150		254,80
GNDB-B40 600R D	18,700	400	2	150		261,80
GNDB-B50 600R D	19,200	500	2	150		268,80
GNDB-B60 600R D	19,700	600	2	150		275,80
GNDB-C20 600R D	21,500	200	2	200		301,00
GNDB-C30 600R D	22,000	300	2	200		308,00
GNDB-C40 600R D	22,500	400	2	200		315,00
GNDB-C50 600R D	23,000	500	2	200		322,00
GNDB-C60 600R D	23,500	600	2	200		329,00

Kaplama : TS 914 EN ISO-1461 (BS-EN-ISO-1461) Sıcak Daldırma Galvaniz.  
Coating : TS 914 EN ISO-1461 (BS-EN-ISO-1461) Hot Dip Galvanized

Talep üzerine tüm ürünler RODINO 50® malzemesi ile kaplanarak (max) 400°C ısıya, asit, tuz ve kum etkilerine karşı mukavemet sağlar.  
In case of required all type of materials can be coated with RODINO 50® which will give on extra resistant at effect of 400°C heat, acid, salt and sand for the material.

DÖRTLÜ BAĞLANTI ELEMANI KAPAKLARI *Crossing "T" Element Covers*

Пересечение Покрывтий Элемента

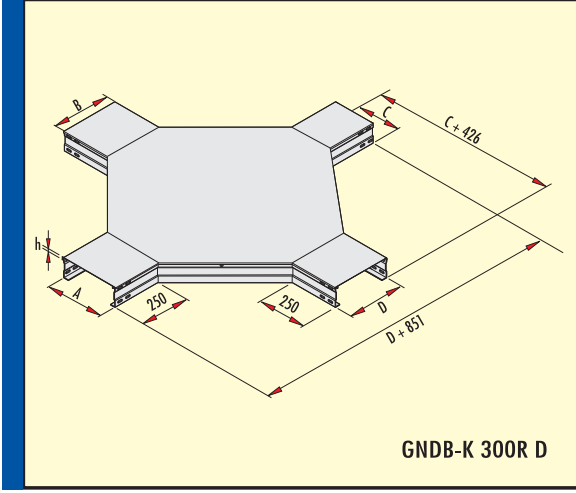

Dörtlü Bağlantı Eleman Kapığı 300 Radius  
*Crossing Element Cover Radius 300*

Пересечение Радиуса Покр ытия Элемента 300

Sipariş kodu Order code Код заявки	Ağırlık (Kg/ad.) Weight (Kg/unit) Вес (кг /шт)	A-B-C-D mm	e mm	h mm	Price list прайс-лист шт /у.е.	
					Pre-Galvanized Предв. Цинк-ия	Hot dip Galvanized гор.оцинк. HDZ
GND-B-20K 300R D	4,950	200	1	9		69,30
GND-B-30K 300R D	6,100	300	1	9		85,40
GND-B-40K 300R D	12,300	400	1.5	9		172,20
GND-B-50K 300R D	15,800	500	1.5	9		221,20
GND-B-60K 300R D	19,500	600	1.5	9		273,00

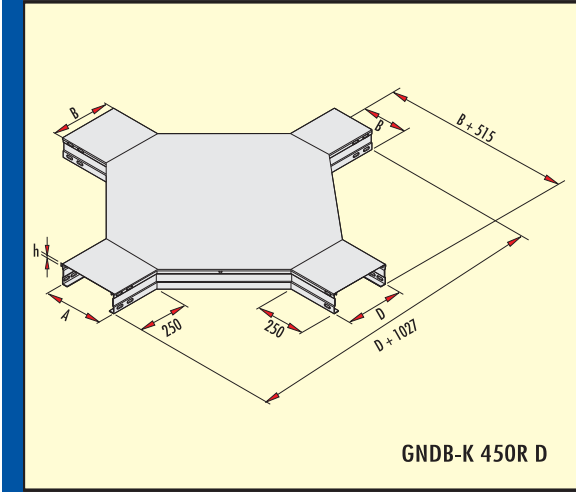

Dörtlü Bağlantı Eleman Kapığı 450 Radius  
*Crossing Element Cover Radius 450*

Пересечение Радиуса Покр ытия Элемента 450

Sipariş kodu Order code Код заявки	Ağırlık (Kg/ad.) Weight (Kg/unit) Вес (кг /шт)	A-B-C-D mm	e mm	h mm	Price list прайс-лист шт /у.е.	
					Pre-Galvanized Предв. Цинк-ия	Hot dip Galvanized гор.оцинк. HDZ
GND-B-20K 450R D	5,450	200	1	9		76,30
GND-B-30K 450R D	7,600	300	1	9		106,40
GND-B-40K 450R D	15,150	400	1.5	9		212,10
GND-B-50K 450R D	19,000	500	1.5	9		266,00
GND-B-60K 450R D	23,200	600	1.5	9		324,80

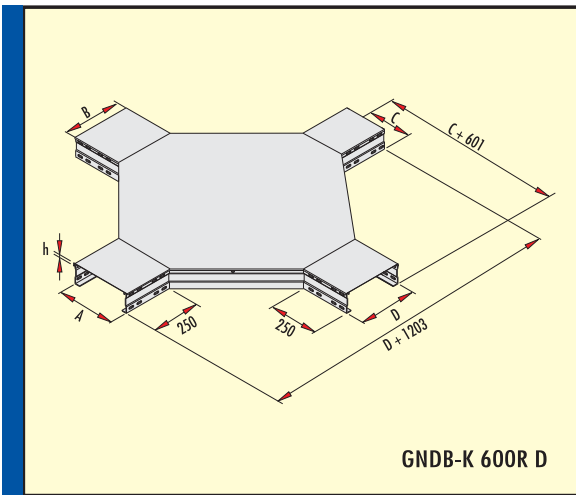

Dörtlü Bağlantı Eleman Kapığı 600 Radius  
*Crossing Element Cover Radius 600*

Пересечение Радиуса Покр ытия Элемента 600

Sipariş kodu Order code Код заявки	Ağırlık (Kg/ad.) Weight (Kg/unit) Вес (кг /шт)	A-B-C-D mm	e mm	h mm	Price list прайс-лист шт /у.е.	
					Pre-Galvanized Предв. Цинк-ия	Hot dip Galvanized гор.оцинк. HDZ
GND-B-20K 600R D	7,100	200	1	9		99,40
GND-B-30K 600R D	9,650	300	1	9		135,10
GND-B-40K 600R D	18,550	400	1.5	9		259,70
GND-B-50K 600R D	22,900	500	1.5	9		320,60
GND-B-60K 600R D	27,500	600	1.5	9		385,00

Kaplama : TS 914 EN ISO-1461 (BS-EN-ISO-1461) Sıcak Daldırma Galvaniz. Coating : TS 914 EN ISO-1461 (BS-EN-ISO-1461) Hot Dip Galvanized

Talep üzerine tüm ürünler RODINO 50® malzemesi ile kaplanarak (max) 400°C ısıya, asit, tuz ve kum etkilerine karşı mukavemet sağlar.

In case of required all type of materials can be coated with RODINO 50® which will give on extra resistant at effect of 400°C heat, acid, salt and sand for the material.

## İÇ BÜKEY ELEMANLARI

## Internal Riser Elements

Внутренние Элементы Надстрочного элемента

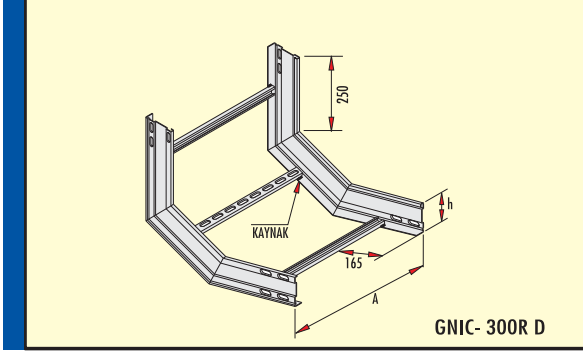

### İç Bükey Elemanı 300 Radius Internal Riser Element Radius 300

Внутренний Радиус Элемента Надстрочного элемента 300

Sipariş kodu Order code Код заявки	Ağırlık (Kg/ad.) Weight (Kg/unit) Вес (кг / шт)	A mm	e mm	h mm	Price list прайс-лист шт / у.е.	
					Pre-Galvanized Предв. Цинк-ия	Hot dip Galvanized гор.оцинк. HDZ
GNIC-20 300R D	3,600	200	2	70		50,40
GNIC-30 300R D	3,800	300	2	70		53,20
GNIC-40 300R D	4,000	400	2	70		56,00
GNIC-50 300R D	4,200	500	2	70		58,80
GNIC-60 300R D	4,400	600	2	70		61,60
GNIC-A20 300R D	4,450	200	2	100		62,30
GNIC-A30 300R D	4,650	300	2	100		65,10
GNIC-A40 300R D	4,850	400	2	100		67,90
GNIC-A50 300R D	5,050	500	2	100		70,70
GNIC-A60 300R D	5,250	600	2	100		73,50
GNIC-B20 300R D	7,100	200	2	150		99,40
GNIC-B30 300R D	7,300	300	2	150		102,20
GNIC-B40 300R D	7,500	400	2	150		105,00
GNIC-B50 300R D	7,700	500	2	150		107,80
GNIC-B60 300R D	7,900	600	2	150		110,60
GNIC-C20 300R D	8,900	200	2	200		124,60
GNIC-C30 300R D	9,200	300	2	200		128,80
GNIC-C40 300R D	9,500	400	2	200		133,00
GNIC-C50 300R D	9,800	500	2	200		137,20
GNIC-C60 300R D	10,100	600	2	200		141,40

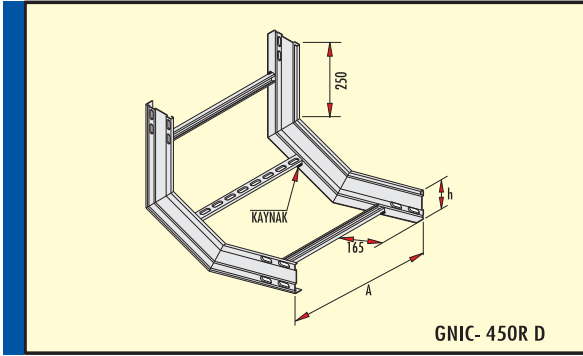

### İç Bükey Elemanı 450 Radius Internal Riser Element Radius 450

Внутренний Радиус Элемента Надстрочного элемента 450

Sipariş kodu Order code Код заявки	Ağırlık (Kg/ad.) Weight (Kg/unit) Вес (кг / шт)	A mm	e mm	h mm	Price list прайс-лист шт / у.е.	
					Pre-Galvanized Предв. Цинк-ия	Hot dip Galvanized гор.оцинк. HDZ
GNIC-20 450R D	4,000	200	2	70		56,00
GNIC-30 450R D	4,200	300	2	70		58,80
GNIC-40 450R D	4,400	400	2	70		61,60
GNIC-50 450R D	4,600	500	2	70		64,40
GNIC-60 450R D	4,800	600	2	70		67,20
GNIC-A20 450R D	5,000	200	2	100		70,00
GNIC-A30 450R D	5,200	300	2	100		72,80
GNIC-A40 450R D	5,400	400	2	100		75,60
GNIC-A50 450R D	5,600	500	2	100		78,40
GNIC-A60 450R D	5,800	600	2	100		81,20
GNIC-B20 450R D	8,000	200	2	150		112,00
GNIC-B30 450R D	8,200	300	2	150		114,80
GNIC-B40 450R D	8,400	400	2	150		117,60
GNIC-B50 450R D	8,600	500	2	150		120,40
GNIC-B60 450R D	8,800	600	2	150		123,20
GNIC-C20 450R D	10,100	200	2	200		141,40
GNIC-C30 450R D	10,300	300	2	200		144,20
GNIC-C40 450R D	10,500	400	2	200		147,00
GNIC-C50 450R D	10,700	500	2	200		149,80
GNIC-C60 450R D	10,900	600	2	200		152,60

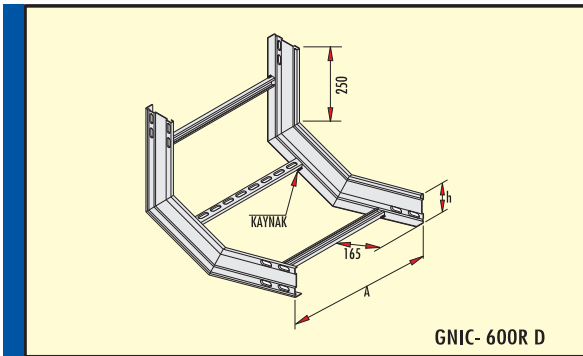

### İç Bükey Elemanı 600 Radius Internal Riser Element Radius 600

Внутренний Радиус Элемента Надстрочного элемента 600

Sipariş kodu Order code Код заявки	Ağırlık (Kg/ad.) Weight (Kg/unit) Вес (кг / шт)	A mm	e mm	h mm	Price list прайс-лист шт / у.е.	
					Pre-Galvanized Предв. Цинк-ия	Hot dip Galvanized гор.оцинк. HDZ
GNIC-20 600R D	4,450	200	2	70		62,30
GNIC-30 600R D	4,650	300	2	70		65,10
GNIC-40 600R D	4,850	400	2	70		67,90
GNIC-50 600R D	5,050	500	2	70		70,70
GNIC-60 600R D	5,250	600	2	70		73,50
GNIC-A20 600R D	5,550	200	2	100		77,70
GNIC-A30 600R D	5,750	300	2	100		80,50
GNIC-A40 600R D	5,950	400	2	100		83,30
GNIC-A50 600R D	6,150	500	2	100		86,10
GNIC-A60 600R D	6,350	600	2	100		88,90
GNIC-B20 600R D	8,900	200	2	150		124,60
GNIC-B30 600R D	9,100	300	2	150		127,40
GNIC-B40 600R D	9,300	400	2	150		130,20
GNIC-B50 600R D	9,500	500	2	150		133,00
GNIC-B60 600R D	9,700	600	2	150		135,80
GNIC-C20 600R D	11,300	200	2	200		158,20
GNIC-C30 600R D	11,500	300	2	200		161,00
GNIC-C40 600R D	11,700	400	2	200		163,80
GNIC-C50 600R D	11,900	500	2	200		166,60
GNIC-C60 600R D	12,100	600	2	200		169,40

Kaplama : TS 914 EN ISO-1461 (BS-EN-ISO-1461) Sıcak Daldırma Galvaniz.

Coating : TS 914 EN ISO-1461 (BS-EN-ISO-1461) Hot Dip Galvanized

Talep üzerine tüm ürünler RODINO 50® malzemesi ile kaplanarak (max) 400°C ısıya, asit, tuz ve kum etkilerine karşı mukavemet sağlar.

In case of required all type of materials can be coated with RODINO 50® which will give on extra resistant at effect of 400°C heat, acid, salt and sand for the material.



İÇ BÜKEY ELEMAN KAPAKLARI

Internal Riser Element Covers

Внутренние Покртия Элемента Надстрочного элемента

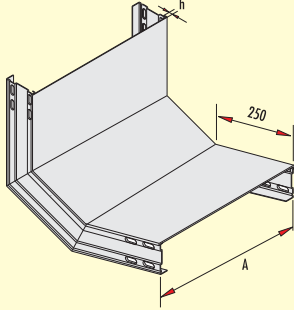

GNIC-K 300R D

İç Bükey Eleman Kapağı 300 Radüs  
Internal Riser Cover Radius 300

Внутренний Радиус Покртия Надстрочного элемента 300

Sipariş kodu Order code Код заявки	Ağırlık (Kg/ad.) Weight (Kg/unit) Вес (кг/шт)	A-B-C-D mm	e mm	h mm	Price list прайс-лист шт/у.е.	
					Pre-Galvanized Предв. Цинк-ия	Hot dip Galvanized гор.оцинк. HDZ
GNIC-20K 300R D	1,450	200	1	9		20,30
GNIC-30K 300R D	2,100	300	1	9		29,40
GNIC-40K 300R D	4,150	400	1.5	9		58,10
GNIC-50K 300R D	5,150	500	1.5	9		72,10
GNIC-60K 300R D	6,150	600	1.5	9		86,10

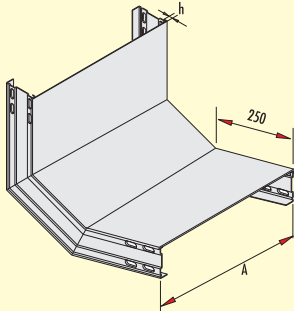

GNIC-K 450R D

İç Bükey Eleman Kapağı 450 Radüs  
Internal Riser Cover Radius 450

Внутренний Радиус Покртия Надстрочного элемента 450

Sipariş kodu Order code Код заявки	Ağırlık (Kg/ad.) Weight (Kg/unit) Вес (кг/шт)	A-B-C-D mm	e mm	h mm	Price list прайс-лист шт/у.е.	
					Pre-Galvanized Предв. Цинк-ия	Hot dip Galvanized гор.оцинк. HDZ
GNIC-20K 450R D	1,700	200	1	9		23,80
GNIC-30K 450R D	2,450	300	1	9		34,30
GNIC-40K 450R D	4,850	400	1.5	9		67,90
GNIC-50K 450R D	6,000	500	1.5	9		84,00
GNIC-60K 450R D	7,150	600	1.5	9		100,10

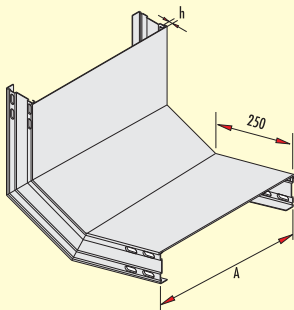

GNIC-K 600R D

İç Bükey Eleman Kapağı 600 Radüs  
Internal Riser Cover Radius 600

Внутренний Радиус Покртия Надстрочного элемента 600

Sipariş kodu Order code Код заявки	Ağırlık (Kg/ad.) Weight (Kg/unit) Вес (кг/шт)	A-B-C-D mm	e mm	h mm	Price list прайс-лист шт/у.е.	
					Pre-Galvanized Предв. Цинк-ия	Hot dip Galvanized гор.оцинк. HDZ
GNIC-20K 600R D	1,950	200	1	9		27,30
GNIC-30K 600R D	2,800	300	1	9		39,20
GNIC-40K 600R D	5,500	400	1.5	9		77,00
GNIC-50K 600R D	6,850	500	1.5	9		95,90
GNIC-60K 600R D	8,150	600	1.5	9		114,10

Kaplama : TS 914 EN ISO-1461 (BS-EN-ISO-1461) Sıcak Daldırma Galvaniz. Coating : TS 914 EN ISO-1461 (BS-EN-ISO-1461) Hot Dip Galvanized

Talep üzerine tüm ürünler RODINO 50® malzemesi ile kaplanarak (max) 400°C ısıya, asit, tuz ve kum etkilerine karşı mukavemet sağlar.

In case of required all type of materials can be coated with RODINO 50® which will give on extra resistant at effect of 400°C heat, acid, salt and sand for the material.

DIŞ BÜKEY ELEMANLARI

External Riser Elements

Внешние Элементы Надстрочного элемента

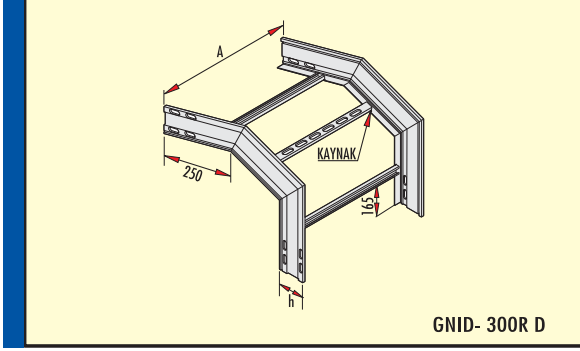

GNID- 300R D

Sipariş kodu Order code Код заявки	Ağırlık (Kg/ad.) Weight (Kg/unit) Вес (кг/шт)	A mm	e mm	h mm	Price list прайс-лист шт /у.е.	
					Pre-Galvanized Предв. Цинк-ия	Hot dip Galvanized гор.оцинк. HDZ
					Dış Bükey Elemanı 300 Radius External Riser Element Radius 300 Внутренний Радиус Элемента Надстрочного элемента 300	
GNID-20 300R D	3,600	200	2	70		50,40
GNID-30 300R D	3,800	300	2	70		53,20
GNID-40 300R D	4,000	400	2	70		56,00
GNID-50 300R D	4,200	500	2	70		58,80
GNID-60 300R D	4,400	600	2	70		61,60
GNID-A20 300R D	4,450	200	2	100		62,30
GNID-A30 300R D	4,650	300	2	100		65,10
GNID-A40 300R D	4,850	400	2	100		67,90
GNID-A50 300R D	5,050	500	2	100		70,70
GNID-A60 300R D	5,250	600	2	100		73,50
GNID-B20 300R D	7,100	200	2	150		99,40
GNID-B30 300R D	7,300	300	2	150		102,20
GNID-B40 300R D	7,500	400	2	150		105,00
GNID-B50 300R D	7,700	500	2	150		107,80
GNID-B60 300R D	7,900	600	2	150		110,60
GNID-C20 300R D	8,900	200	2	200		124,60
GNID-C30 300R D	9,200	300	2	200		128,80
GNID-C40 300R D	9,500	400	2	200		133,00
GNID-C50 300R D	9,800	500	2	200		137,20
GNID-C60 300R D	10,100	600	2	200		141,40

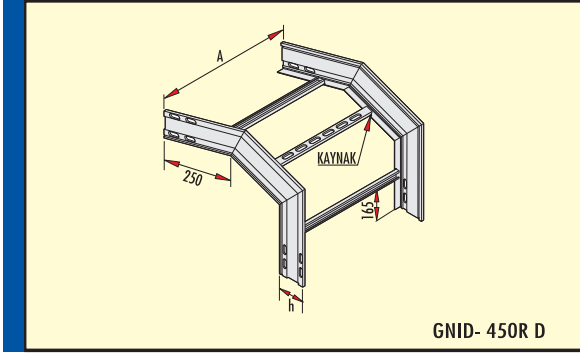

GNID- 450R D

Sipariş kodu Order code Код заявки	Ağırlık (Kg/ad.) Weight (Kg/unit) Вес (кг/шт)	A mm	e mm	h mm	Price list прайс-лист шт /у.е.	
					Pre-Galvanized Предв. Цинк-ия	Hot dip Galvanized гор.оцинк. HDZ
					Dış Bükey Elemanı 450 Radius External Riser Element Radius 450 Внутренний Радиус Элемента Надстрочного элемента 450	
GNID-20 450R D	4,000	200	2	70		56,00
GNID-30 450R D	4,200	300	2	70		58,80
GNID-40 450R D	4,400	400	2	70		61,60
GNID-50 450R D	4,600	500	2	70		64,40
GNID-60 450R D	4,800	600	2	70		67,20
GNID-A20 450R D	5,000	200	2	100		70,00
GNID-A30 450R D	5,200	300	2	100		72,80
GNID-A40 450R D	5,400	400	2	100		75,60
GNID-A50 450R D	5,600	500	2	100		78,40
GNID-A60 450R D	5,800	600	2	100		81,20
GNID-B20 450R D	8,000	200	2	150		112,00
GNID-B30 450R D	8,200	300	2	150		114,80
GNID-B40 450R D	8,400	400	2	150		117,60
GNID-B50 450R D	8,600	500	2	150		120,40
GNID-B60 450R D	8,800	600	2	150		123,20
GNID-C20 450R D	10,100	200	2	200		141,40
GNID-C30 450R D	10,300	300	2	200		144,20
GNID-C40 450R D	10,500	400	2	200		147,00
GNID-C50 450R D	10,700	500	2	200		149,80
GNID-C60 450R D	10,900	600	2	200		152,60

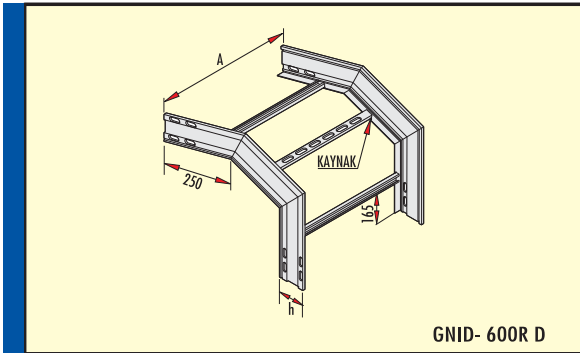

GNID- 600R D

Sipariş kodu Order code Код заявки	Ağırlık (Kg/ad.) Weight (Kg/unit) Вес (кг/шт)	A mm	e mm	h mm	Price list прайс-лист шт /у.е.	
					Pre-Galvanized Предв. Цинк-ия	Hot dip Galvanized гор.оцинк. HDZ
					Dış Bükey Elemanı 600 Radius External Riser Element Radius 600 Внутренний Радиус Элемента Надстрочного элемента 600	
GNID-20 600R D	4,450	200	2	70		62,30
GNID-30 600R D	4,650	300	2	70		65,10
GNID-40 600R D	4,850	400	2	70		67,90
GNID-50 600R D	5,050	500	2	70		70,70
GNID-60 600R D	5,250	600	2	70		73,50
GNID-A20 600R D	5,550	200	2	100		77,70
GNID-A30 600R D	5,750	300	2	100		80,50
GNID-A40 600R D	5,950	400	2	100		83,30
GNID-A50 600R D	6,150	500	2	100		86,10
GNID-A60 600R D	6,350	600	2	100		88,90
GNID-B20 600R D	8,900	200	2	150		124,60
GNID-B30 600R D	9,100	300	2	150		127,40
GNID-B40 600R D	9,300	400	2	150		130,20
GNID-B50 600R D	9,500	500	2	150		133,00
GNID-B60 600R D	9,700	600	2	150		135,80
GNID-C20 600R D	11,300	200	2	200		158,20
GNID-C30 600R D	11,500	300	2	200		161,00
GNID-C40 600R D	11,700	400	2	200		163,80
GNID-C50 600R D	11,900	500	2	200		166,60
GNID-C60 600R D	12,100	600	2	200		169,40

Kaplama : TS 914 EN ISO-1461 (BS-EN-ISO-1461) Sıcak Daldırma Galvaniz. Coating : TS 914 EN ISO-1461 (BS-EN-ISO-1461) Hot Dip Galvanized

Talep üzerine tüm ürünler RODINO 50® malzemesi ile kaplanarak (max) 400°C ısıya, asit, tuz ve kum etkilerine karşı mukavemet sağlar.

In case of required all type of materials can be coated with RODINO 50® which will give on extra resistant at effect of 400°C heat, acid, salt and sand for the material.

DİŞ BÜKEY ELEMAN KAPAKLARI *External Riser Element Covers*

Внешние Покрyтия Элемента Надстрочного элемента

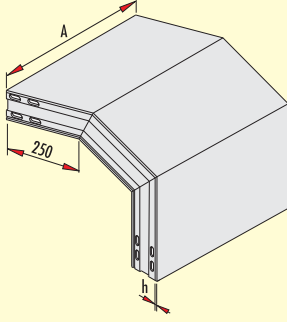

GNID-K 300R D

Dış Bükey Eleman Kapağı 300 Radüs  
*External Riser Cover Radius 300*

Внешние Радиус Покрyтия Надстрочного элемента 300

Sipariş kodu <i>Order code</i> Код заявки	Ağırlık (Kg/ad.) <i>Weight (Kg/unit)</i> Вес (кг / шт)	A mm	e mm	h mm	Price list прайс-лист шт / у.е.	
					Pre-Galvanized Предв. Цинк-ия	Hot dip Galvanized гор.оцинк. HDZ
GNID-20K 300R D	1,750	200	1	9		24,50
GNID-30K 300R D	2,550	300	1	9		35,70
GNID-40K 300R D	5,000	400	1,5	9		70,00
GNID-50K 300R D	6,200	500	1,5	9		86,80
GNID-60K 300R D	7,400	600	1,5	9		103,60

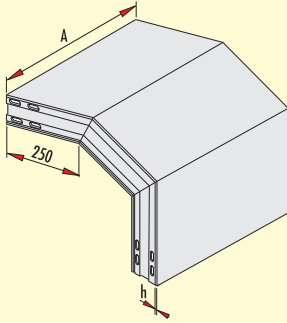

GNID-K 450R D

Dış Bükey Eleman Kapağı 450 Radüs  
*External Riser Cover Radius 450*

Внешние Радиус Покрyтия Надстрочного элемента 450

Sipariş kodu <i>Order code</i> Код заявки	Ağırlık (Kg/ad.) <i>Weight (Kg/unit)</i> Вес (кг / шт)	A mm	e mm	h mm	Price list прайс-лист шт / у.е.	
					Pre-Galvanized Предв. Цинк-ия	Hot dip Galvanized гор.оцинк. HDZ
GNID-20K 450R D	2,000	200	1	9		28,00
GNID-30K 450R D	2,900	300	1	9		40,60
GNID-40K 450R D	5,700	400	1,5	9		79,80
GNID-50K 450R D	7,100	500	1,5	9		99,40
GNID-60K 450R D	8,450	600	1,5	9		118,30

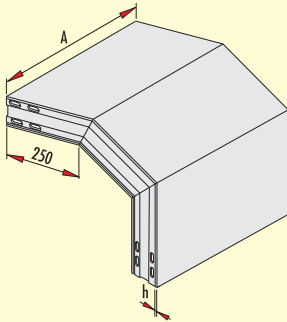

GNID-K 600R D

Dış Bükey Eleman Kapağı 600 Radüs  
*External Riser Cover Radius 600*

Внешние Радиус Покрyтия Надстрочного элемента 600

Sipariş kodu <i>Order code</i> Код заявки	Ağırlık (Kg/ad.) <i>Weight (Kg/unit)</i> Вес (кг / шт)	A mm	e mm	h mm	Price list прайс-лист шт / у.е.	
					Pre-Galvanized Предв. Цинк-ия	Hot dip Galvanized гор.оцинк. HDZ
GNID-20K 600R D	2,250	200	1	9		31,50
GNID-30K 600R D	3,250	300	1	9		45,50
GNID-40K 600R D	6,400	400	1,5	9		89,60
GNID-50K 600R D	8,000	500	1,5	9		112,00
GNID-60K 600R D	9,500	600	1,5	9		133,00

Kaplama : TS 914 EN ISO-1461 (BS-EN-ISO-1461) Sıcak Daldırma Galvaniz. *Coating : TS 914 EN ISO-1461 (BS-EN-ISO-1461) Hot Dip Galvanized*

Talep üzerine tüm ürünler RODINO 50® malzemesi ile kaplanarak (max) 400°C ısıya, asit, tuz ve kum etkilerine karşı mukavemet sağlar.

*In case of required all type of materials can be coated with RODINA 50® which will give on extra resistant at effect of 400°C heat, acid, salt and sand for the material.*

135° DÖNÜŞ ELEMANLARI

135° Flat Bend Elements

135° Квартир Сгибают Элемент

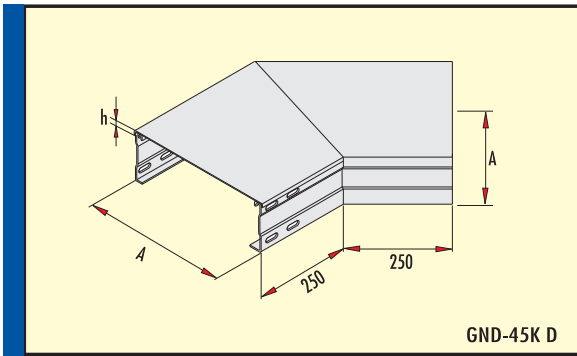
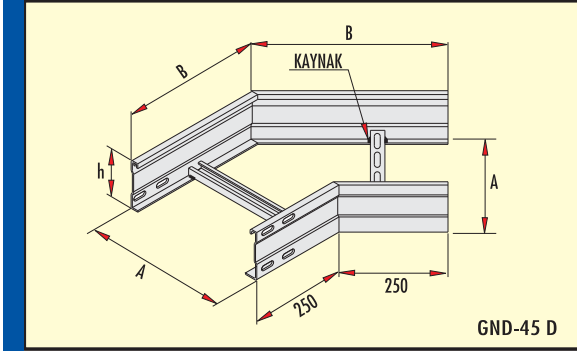

135° Dönüş Elemanı 135° Flat Bend Element						
135° Квартир Сгибают Элемент						
Sipariş kodu Order code Код заявки	Ağırlık (Kg/ad.) Weight (Kg/unit) Вес (кг / шт)	A mm	B mm	e mm	h mm	Price list прайс-лист шт/у.е.
						Pre-Galvanized Предв. Цинк-ия
GND-20-45 D	2,350	200	333	2	70	32,90
GND-30-45 D	2,600	300	375	2	70	36,40
GND-40-45 D	2,900	400	417	2	70	40,60
GND-50-45 D	3,200	500	457	2	70	44,80
GND-60-45 D	3,500	600	499	2	70	49,00
GND-A20-45 D	2,900	200	333	2	100	40,60
GND-A30-45 D	3,200	300	375	2	100	44,80
GND-A40-45 D	3,500	400	417	2	100	49,00
GND-A50-45 D	3,850	500	457	2	100	53,90
GND-A60-45 D	4,200	600	499	2	100	58,80
GND-B20-45 D	4,600	200	333	2	150	64,40
GND-B30-45 D	5,050	300	375	2	150	70,70
GND-B40-45 D	5,500	400	417	2	150	77,00
GND-B50-45 D	5,950	500	457	2	150	83,30
GND-B60-45 D	6,500	600	499	2	150	91,00
GND-C20-45 D	5,750	200	333	2	200	80,50
GND-C30-45 D	6,300	300	375	2	200	88,20
GND-C40-45 D	6,850	400	417	2	200	95,90
GND-C50-45 D	7,500	500	457	2	200	105,00
GND-C60-45 D	8,000	600	499	2	200	112,00

135° Dönüş Elemanı Kapağı 135° Flat Bend Element Cover						
135° Квартир Сгибают Покрытие Элемента						
Sipariş kodu Order code Код заявки	Ağırlık (Kg/ad.) Weight (Kg/unit) Вес (кг / шт)	A mm	B mm	e mm	h mm	Price list прайс-лист шт/у.е.
						Pre-Galvanized Предв. Цинк-ия
GND-20-45K D	1,050	200	333	1	9	14,70
GND-20-45K D	1,600	300	375	1	9	22,40
GND-20-45K D	3,200	400	417	1,5	9	44,80
GND-20-45K D	4,400	500	457	1,5	9	61,60
GND-20-45K D	5,500	600	499	1,5	9	77,00

Kaplama : TS 914 EN ISO-1461 (BS-EN-ISO-1461) Sıcak Daldırma Galvaniz. Coating : TS 914 EN ISO-1461 (BS-EN-ISO-1461) Hot Dip Galvanized

GND RADÜSLÜ 30° DIŞ BÜKEY ELEMANI

(GNID) Radiused 30° External riser

Внешние вертикальные угловые элементы 30° «GNID» с радиусом

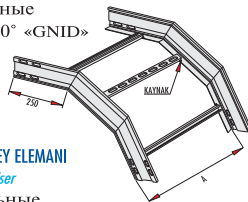

GND RADÜSLÜ 45° DIŞ BÜKEY ELEMANI

(GNID) Radiused 45° External riser

Внешние вертикальные угловые элементы 45° «GNID» с радиусом



GND RADÜSLÜ 60° DIŞ BÜKEY ELEMANI

(GNID) Radiused 60° External riser

Внешние вертикальные угловые элементы 60° «GNID» с радиусом

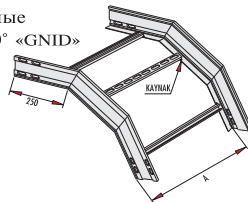

GNIC RADÜSLÜ 30° İÇ BÜKEY ELEMANI

(GNIC) Radiused 30° Internal riser

Внутренние вертикальные угловые элементы 30° «GNIC» с радиусом

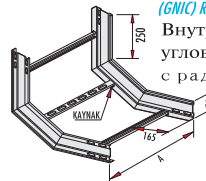

GNIC RADÜSLÜ 45° İÇ BÜKEY ELEMANI

(GNIC) Radiused 45° Internal riser

Внутренние вертикальные угловые элементы 45° «GNIC» с радиусом

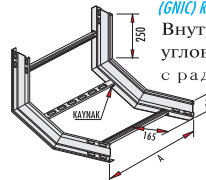

GNIC RADÜSLÜ 60° İÇ BÜKEY ELEMANI

(GNIC) Radiused 60° Internal riser

Внутренние вертикальные угловые элементы 60° «GNIC» с радиусом

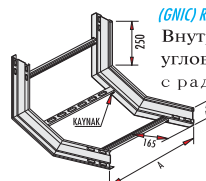

İsteğe bağlı olarak iç-dış bükelyer 300-450-600 radüslü ve 30° - 45° - 60° olarak imal edilir.  
Internal and external risers can be produced with 300 - 450 - 600 radiuses for 30° - 45° - 60° due to request.

При необходимости наружные и внутренние выпуклые элементы могут быть изготовлены диаметрами 300-450-600 для 30°-45°-60° согласно заказа.

Talep üzerine tüm ürünler RODINO 50® malzemesi ile kaplanarak (max) 400°C ısıya, asit, tuz ve kum etkilerine karşı mukavemet sağlar.

In case of required all type of materials can be coated with RODINO 50® which will give an extra resistant at effect of 400°C heat, acid, salt and sand for the material.



## SEVİYE AYAR ELEMANLARI

## Level Changer

Опорные элементы

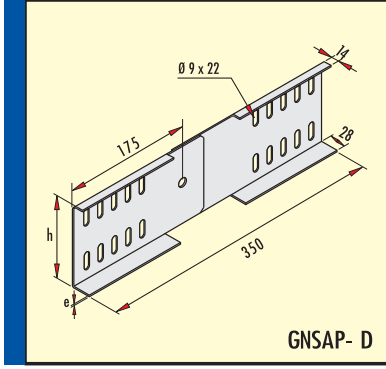

Seviye Ayar Elemanları Level Changer					
Опорные элементы					
Sipariş kodu Order code Код заявки	Ağırlık (Kg/ad.) Weight (Kg/unit) Вес (кг/шт)	h mm	e mm	Price list прайс-лист шт./у.е.	
				Pre-Galvanized Предв. Цинк-ия	Hot dip Galvanized гор.оцинк. HDZ
GNSAP-70 D	0,600	76	2		9,60
GNSAP-100 D	0,850	106	2		13,60
GNSAP-150 D	1,100	156	2		17,60
GNSAP-200 D	1,550	206	2		24,80

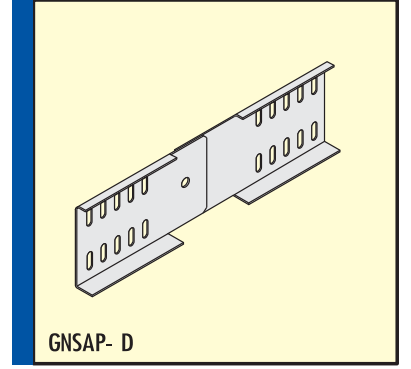

## YÖN DEĞİŞTİRME ELEMANLARI

## Direction Changer

Соединительный элемент изменяющий направление

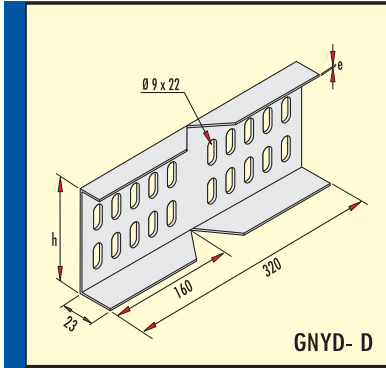

Yön Değişirme Elemanları					
Direction Changer					
Соединительный элемент изменяющий направление					
Sipariş kodu Order code Код заявки	Ağırlık (Kg/ad.) Weight (Kg/unit) Вес (кг/шт)	h mm	e mm	Price list прайс-лист шт./у.е.	
				Pre-Galvanized Предв. Цинк-ия	Hot dip Galvanized гор.оцинк. HDZ
GNYD-70 D	0,500	76	2		8,00
GNYD-100 D	0,600	106	2		9,60
GNYD-150 D	0,900	156	2		14,40
GNYD-200 D	1,200	206	2		19,20

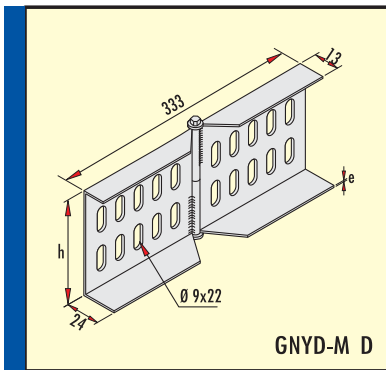
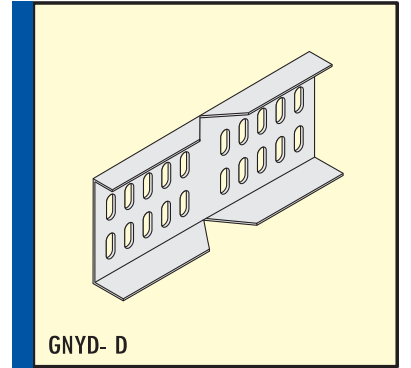

Yön Değişirme Elemanları					
Direction Changer					
Соединительный элемент изменяющий направление					
Sipariş kodu Order code Код заявки	Ağırlık (Kg/ad.) Weight (Kg/unit) Вес (кг/шт)	h mm	e mm	Price list прайс-лист шт./у.е.	
				Pre-Galvanized Предв. Цинк-ия	Hot dip Galvanized гор.оцинк. HDZ
GNYD-M70 D	0,500	76	2		8,00
GNYD-M100 D	0,600	106	2		9,60
GNYD-M150 D	0,900	156	2		14,40
GNYD-M200 D	1,200	206	2		19,20

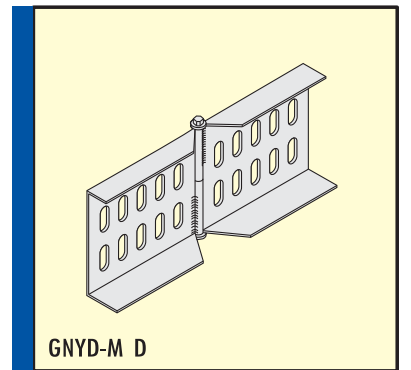

Kaplama : TS 914 EN ISO-1461 (BS-EN-ISO-1461) Sıcak Daldırma Galvaniz.  
Bu Ürünler İsteğe Bağlı Olarak Pregalvaniz ve CORTEN-A Sacdan İmal Edilebilir.

Coating : TS 914 EN ISO-1461 (BS-EN-ISO-1461) Hot Dip Galvanized

These products can be produced from Pregalvanized or CORTEN-A Steel according to the requirements.

Talep üzerine tüm ürünler RODINO 50® malzemesi ile kaplanarak (max) 400°C ısıya, asit, tuz ve kum etkilerine karşı mukavemet sağlar.

In case of required all type of materials can be coated with RODINO 50® which will give on extra resistant at effect of 400°C heat, acid, salt and sand for the material.



## AĞIR HİZMET TİPİ KABLO MERDİVENLERİ

## Heavy Duty Type Cable Ladders

Сверхмощные лестничные лотки

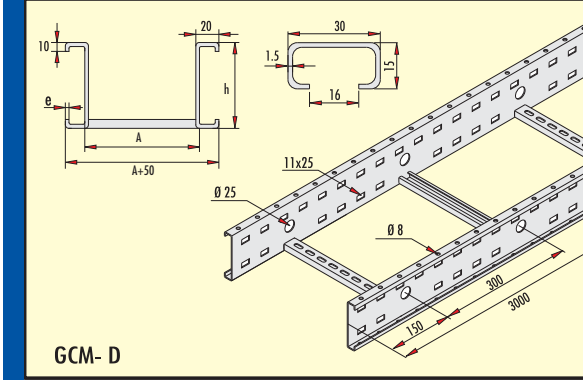

Ağır Hizmet Tipi Kablo Merdiveni (h=100 mm)  
Heavy Duty Type Cable Ladder (h=100 mm)  
Сверхмощные лестничные лотки

Sipariş kodu Order code Код заявки	Ağırlık (Kg/mt.) Weight (Kg/mt) Вес (кг/м)	A mm	e mm	h mm	Price list прайс-лист М/у.е.	
					Pre-Galvanized Предв. Цинк-ия	Hot dip Galvanized гор.оцинк. HDZ
GCM-20 D	4,150	200	2	100		41,50
GCM-30 D	4,350	300	2	100		43,50
GCM-40 D	4,550	400	2	100		45,50
GCM-50 D	4,750	500	2	100		47,50
GCM-60 D	4,950	600	2	100		49,50

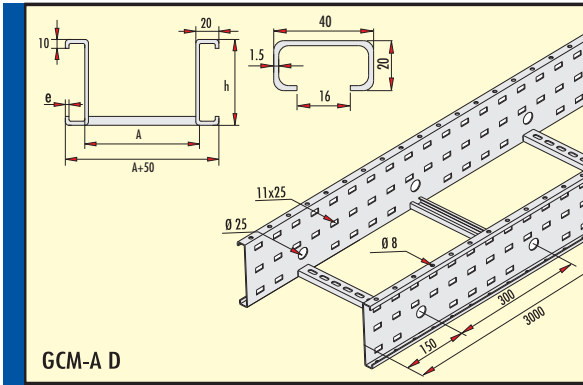

Ağır Hizmet Tipi Kablo Merdiveni (h=150 mm)  
Heavy Duty Type Cable Ladder (h=150 mm)  
Сверхмощные лестничные лотки

Sipariş kodu Order code Код заявки	Ağırlık (Kg/mt.) Weight (Kg/mt) Вес (кг/м)	A mm	e mm	h mm	Price list прайс-лист М/у.е.	
					Pre-Galvanized Предв. Цинк-ия	Hot dip Galvanized гор.оцинк. HDZ
GCM-A20 D	5,400	200	2	150		54,00
GCM-A30 D	5,600	300	2	150		56,00
GCM-A40 D	5,800	400	2	150		58,00
GCM-A50 D	6,000	500	2	150		60,00
GCM-A60 D	6,200	600	2	150		62,00

## EK PARÇASI

## Jointing Piece

Соединительные элементы

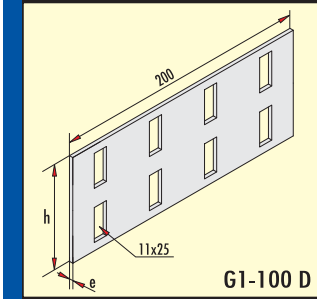

Ek Parçası Jointing Piece

Соединительные элементы

Sipariş kodu Order code Код заявки	Ağırlık (Kg/ad.) Weight (Kg/unit) Вес (кг / шт)	e mm	h mm	Price list прайс-лист шт/у.е.	
				Pre-Galvanized Предв. Цинк-ия	Hot dip Galvanized гор.оцинк. HDZ
G1-100 D	0,230	2	83		3,68
G1-150 D	0,390	2	133		6,24

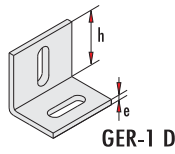
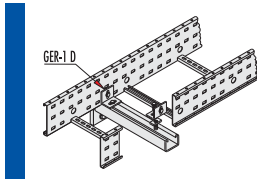
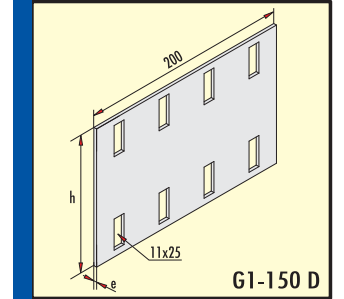

## Merdiven Duvara ve Konsola Tespit Elemanı

## Ladder Fixing unit For Wall and Bracket

элементы крепления лестницы к стене и к консоли

Sipariş kodu Order code Код заявки	Ağırlık (Kg/ad.) Weight (Kg/unit) Вес (кг/шт)	e mm	h mm	Price list прайс-лист шт/у.е.	
				Pre-Galvanized Предв. Цинк-ия	Hot dip Galvanized гор.оцинк. HDZ
GER-1 D	0,076	3	40		1,50

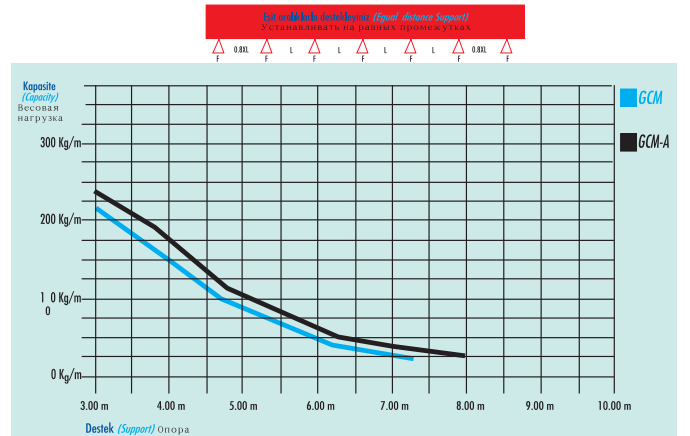

Kaplama : TS 914 EN ISO-1461 (BS-EN-ISO-1461) Sıcak Daldırma Galvaniz.  
Bu ürünler isteğe bağlı olarak Pregalvaniz ve CORTEN-A Saçdan İmal Edilebilir.

Coating : TS 914 EN ISO-1461 (BS-EN-ISO-1461) Hot Dip Galvanized  
These products can be produced from Pregalvanized or CORTEN-A Steel according to the requirements.

Talep üzerine tüm ürünler RODINO 50® malzemesi ile kaplanarak (max) 400°C ısıya, asit, tuz ve kum etkilerine karşı mukavemet sağlar.

In case of required all type of materials can be coated with RODINO 50® which will give on extra resistant at effect of 400°C heat, acid, salt and sand for the material.

DÖNÜŞ ELEMANLARI

Flat Bends

Плоский Изгиб

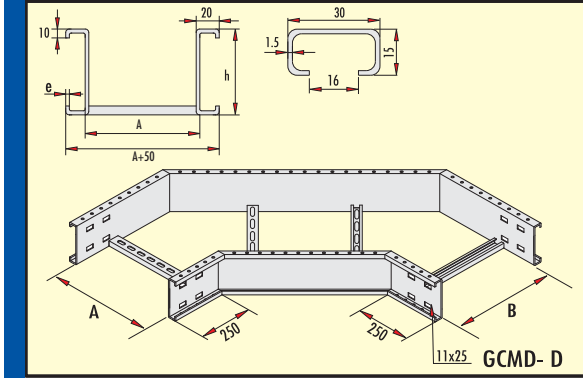

90° Dönüş Elemanı 300 Radius (h=100 mm)  
90° Flat Bend Element Radius 300 (h=100 mm)  
90° Квартир Стибают Элемент

Sipariş kodu Order code Код заявки	Ağırlık (Kg/ad.) Weight (Kg/unit) Вес (кг/шт)	A mm	e mm	h mm	Price list прайс-лист шт./у.е.	
					Pre-Galvanized Предв. Цинк-ия	Hot dip Galvanized гор.оцинк. HDZ
GCMD-20 300R D	3,930	200	2	100		55,02
GCMD-30 300R D	4,550	300	2	100		63,70
GCMD-40 300R D	5,150	400	2	100		72,10
GCMD-50 300R D	5,600	500	2	100		78,40
GCMD-60 300R D	6,350	600	2	100		88,90

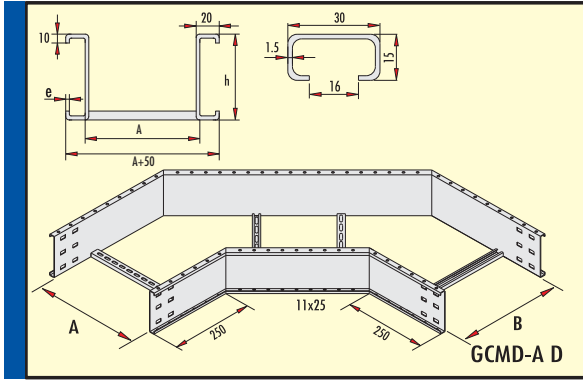

90° Dönüş Elemanı 300 Radius (h=150 mm)  
90° Flat Bend Element Radius 300 (h=150 mm)  
90° Квартир Стибают Элемент

Sipariş kodu Order code Код заявки	Ağırlık (Kg/ad.) Weight (Kg/unit) Вес (кг/шт)	A mm	B mm	e mm	h mm	Price list прайс-лист шт./у.е.	
						Pre-Galvanized Предв. Цинк-ия	Hot dip Galvanized гор.оцинк. HDZ
GCMD-A20 300R D	5,120	200	200	2	150		71,68
GCMD-A30 300R D	5,800	300	300	2	150		81,20
GCMD-A40 300R D	6,500	400	400	2	150		91,00
GCMD-A50 300R D	7,200	500	500	2	150		100,80
GCMD-A60 300R D	7,900	600	600	2	150		110,60

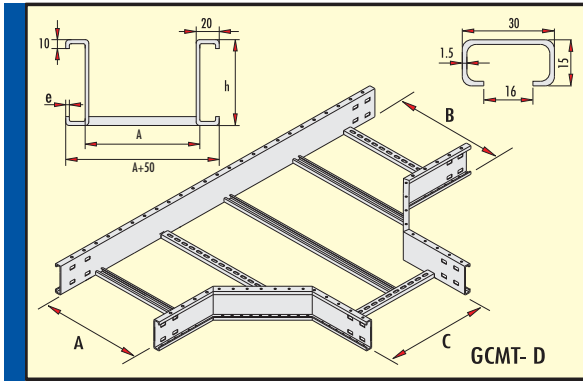

"T" Bağlantı Elemanı 300 Radius (h=100 mm)  
Tee "T" Element Radius 300 (h=100 mm)  
Мишень "Т" Квартира Стибают Элемент

Sipariş kodu Order code Код заявки	Ağırlık (Kg/ad.) Weight (Kg/unit) Вес (кг/шт)	A-B-C mm	e mm	h mm	Price list прайс-лист шт./у.е.	
					Pre-Galvanized Предв. Цинк-ия	Hot dip Galvanized гор.оцинк. HDZ
GCMT-20 300R D	5,970	200	2	100		83,60
GCMT-30 300R D	6,650	300	2	100		93,10
GCMT-40 300R D	7,300	400	2	100		102,20
GCMT-50 300R D	7,970	500	2	100		111,60
GCMT-60 300R D	8,640	600	2	100		121,00

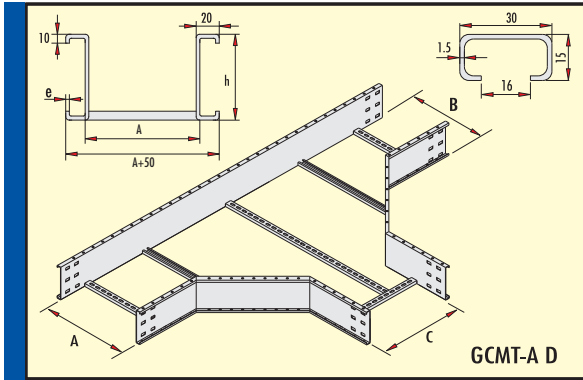

"T" Dönüş Elemanı 300 Radius (h=150 mm)  
Tee "T" Flat Bend Element Radius 300 (h=150 mm)  
Мишень "Т" Квартира Стибают Элемент

Sipariş kodu Order code Код заявки	Ağırlık (Kg/ad.) Weight (Kg/unit) Вес (кг/шт)	A-B-C mm	e mm	h mm	Price list прайс-лист шт./у.е.	
					Pre-Galvanized Предв. Цинк-ия	Hot dip Galvanized гор.оцинк. HDZ
GCMT-A20 300R D	7,550	200	2	150		105,70
GCMT-A30 300R D	8,300	300	2	150		116,20
GCMT-A40 300R D	9,000	400	2	150		126,00
GCMT-A50 300R D	9,420	500	2	150		131,88
GCMT-A60 300R D	10,060	600	2	150		140,84

Bu Ürünler İsteğe Bağlı 450 ve 600 Radüslü Olarak İmal Edilebilir. These products can be manufactured radius 450 and radius 600 due to request.  
Эти продукты могут быть изготовленными радиусом 450 и радиусом 600 из-за request.

Kaplama : TS 914 EN ISO-1461 (BS-EN-ISO-1461) Sacak Daldırma Galvaniz. Coating : TS 914 EN ISO-1461 (BS-EN-ISO-1461) Hot Dip Galvanized  
Bu Ürünler İsteğe Bağlı Olarak Pregalvaniz ve CORTEN-A Sacadan İmal Edilebilir. These products can be produced from Pregalvanized or CORTEN-A Steel according to the requirements.

Talep üzerine tüm ürünler RODINO 50® malzemesi ile kaplanarak (max) 400°C ısıya, asit, tuz ve kum etkilerine karşı mukavemet sağlar.  
In case of required all type of materials can be coated with RODINO 50® which will give on extra resistant at effect of 400°C heat, acid, salt and sand for the material.

DÖNÜŞ ELEMANLARI

Flat Bends

Плоский Изгиб

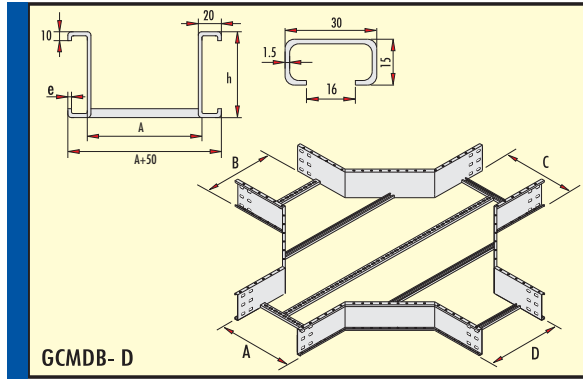

Dörtlü Bağlantı Elemanı 300 Radüs (h=100 mm)  
Crossing Element Radius 300 (h=100 mm)  
Пересечение Элемента

Sipariş kodu Order code Код заявки	Ağırlık (Kg/ad.) Weight (Kg/unit) Вес (кг/шт)	A-B-C-D mm	e mm	h mm	Price list прайс-лист шт./у.е.	
					Pre-Galvanized Предв. Цинк-ия	Hot dip Galvanized гор.оцинк. HDZ
GCMDB-20 300R D	7,660	200	2	100		107,50
GCMDB-30 300R D	8,270	300	2	100		115,80
GCMDB-40 300R D	8,890	400	2	100		124,50
GCMDB-50 300R D	9,550	500	2	100		133,70
GCMDB-60 300R D	10,110	600	2	100		141,60

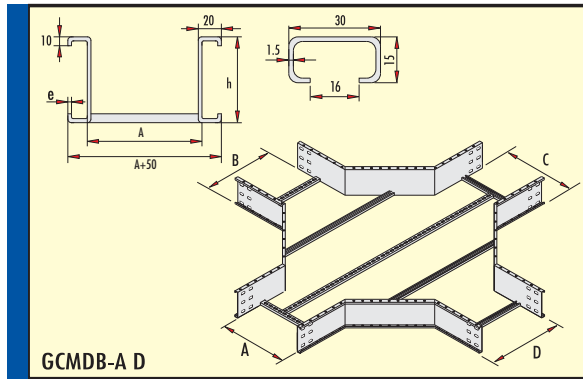

Dörtlü Bağlantı Elemanı 300 Radüs (h=150 mm)  
Crossing Element Radius 300 (h=150 mm)  
Пересечение Элемента

Sipariş kodu Order code Код заявки	Ağırlık (Kg/ad.) Weight (Kg/unit) Вес (кг/шт)	A-B-C-D mm	e mm	h mm	Price list прайс-лист шт./у.е.	
					Pre-Galvanized Предв. Цинк-ия	Hot dip Galvanized гор.оцинк. HDZ
GCMDB-A20 300R D	9,350	200	2	150		130,90
GCMDB-A30 300R D	10,140	300	2	150		142,00
GCMDB-A40 300R D	10,750	400	2	150		150,50
GCMDB-A50 300R D	11,420	500	2	150		160,00
GCMDB-A60 300R D	12,000	600	2	150		168,00

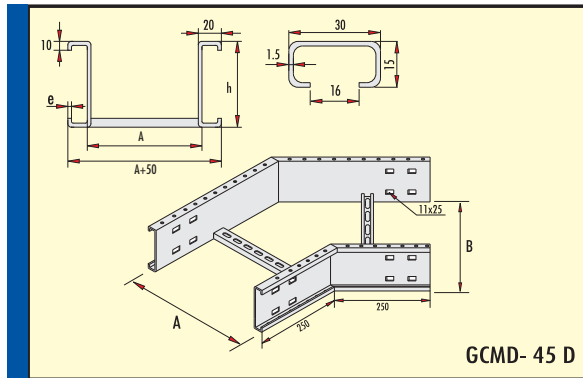

135° Dönüş Elemanı (h=100 mm)  
135° Flat Bend Element (h=100 mm)  
135° Квартир Стибают Элемент

Sipariş kodu Order code Код заявки	Ağırlık (Kg/ad.) Weight (Kg/unit) Вес (кг/шт)	A mm	B mm	e mm	h mm	Price list прайс-лист шт./у.е.	
						Pre-Galvanized Предв. Цинк-ия	Hot dip Galvanized гор.оцинк. HDZ
GCMD- 20-45 D	2,550	200	200	2	100		35,70
GCMD- 30-45 D	3,000	300	300	2	100		42,00
GCMD- 40-45 D	3,330	400	400	2	100		46,70
GCMD- 50-45 D	3,630	500	500	2	100		50,90
GCMD- 60-45 D	4,100	600	600	2	100		57,50

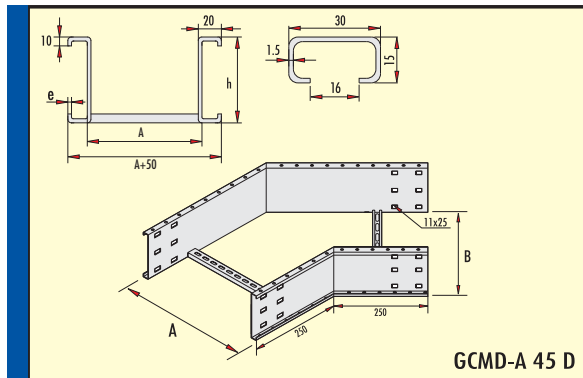

135° Dönüş Elemanı (h=150 mm)  
135° Flat Bend Element (h=150 mm)  
135° Квартир Стибают Элемент

Sipariş kodu Order code Код заявки	Ağırlık (Kg/ad.) Weight (Kg/unit) Вес (кг/шт)	A mm	B mm	e mm	h mm	Price list прайс-лист шт./у.е.	
						Pre-Galvanized Предв. Цинк-ия	Hot dip Galvanized гор.оцинк. HDZ
GCMD- A20-45 D	3,320	200	200	2	150		46,50
GCMD- A30-45 D	3,730	300	300	2	150		52,50
GCMD- A40-45 D	4,150	400	400	2	150		58,10
GCMD- A50-45 D	4,640	500	500	2	150		65,00
GCMD- A60-45 D	5,000	600	600	2	150		70,00

Bu Ürünler İsteğe Bağlı 450 ve 600 Radüslü Olarak İmal Edilebilir. *These products can be manufactured radius 450 and radius 600 due to request.*  
Эти продукты могут быть изготовленными радиусом 450 и радиусом 600 из-за request.

Kaplama : TS 914 EN ISO-1461 (BS-EN-ISO-1461) Sıcak Daldırma Galvaniz. *Coating : TS 914 EN ISO-1461 (BS-EN-ISO-1461) Hot Dip Galvanized*  
Bu Ürünler İsteğe Bağlı Olarak Pregalvaniz ve CORTEN-A Saçdan İmal Edilebilir. *These products can be produced from Pregalvanized or CORTEN-A Steel according to the requirements.*

Talep üzerine tüm ürünler RODINO 50® malzemesi ile kaplanarak (max) 400°C ısıya, asit, tuz ve kum etkilerine karşı mukavemet sağlar.  
*In case of required all type of materials can be coated with RODINO 50® which will give on extra resistant at effect of 400°C heat, acid, salt and sand for the material.*



DÖNÜŞ ELEMANLARI

Flat Bends

Плоский Изгиб

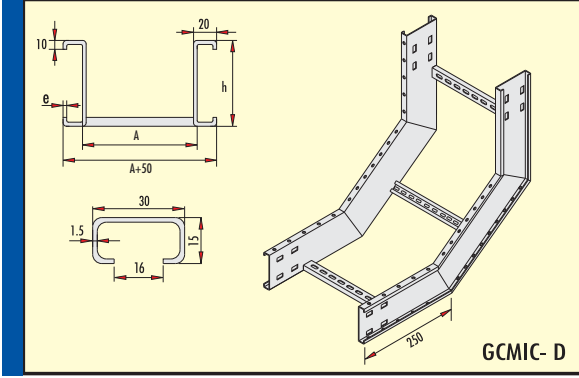

İç Bükü Elemanı (h=100 mm)

Internal Riser Element (h=100 mm)

Внутренние Элементы Надстрочного элемента

Sipariş kodu Order code Код заявки	Ağırlık (Kg/ad.) Weight (Kg/unit) Вес (кг/шт)	A mm	e mm	h mm	Price list прайс-лист шт./у.е.	
					Pre-Galvanized Предв. Цинк-ия	Hot dip Galvanized гор.оцинк. HDZ
GCMIC-20 300R D	3,800	200	2	100		53,20
GCMIC-30 300R D	4,010	300	2	100		56,20
GCMIC-40 300R D	4,220	400	2	100		59,10
GCMIC-50 300R D	4,420	500	2	100		62,00
GCMIC-60 300R D	4,630	600	2	100		65,00

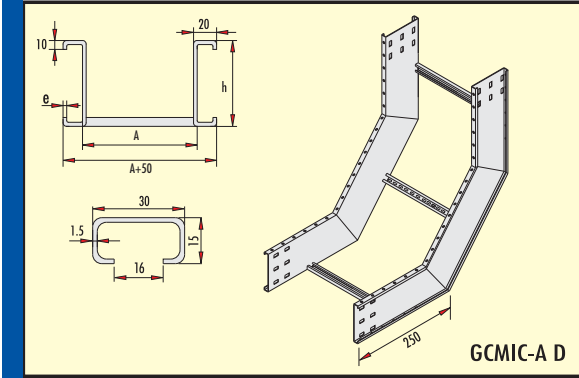

İç Bükü Elemanı (h=150 mm)

Internal Riser Element (h=150 mm)

Внутренние Элементы Надстрочного элемента

Sipariş kodu Order code Код заявки	Ağırlık (Kg/ad.) Weight (Kg/unit) Вес (кг/шт)	A mm	e mm	h mm	Price list прайс-лист шт./у.е.	
					Pre-Galvanized Предв. Цинк-ия	Hot dip Galvanized гор.оцинк. HDZ
GCMIC-A20 300R D	4,950	200	2	150		69,30
GCMIC-A30 300R D	5,150	300	2	150		72,10
GCMIC-A40 300R D	5,350	400	2	150		75,00
GCMIC-A50 300R D	5,560	500	2	150		78,00
GCMIC-A60 300R D	5,760	600	2	150		81,00

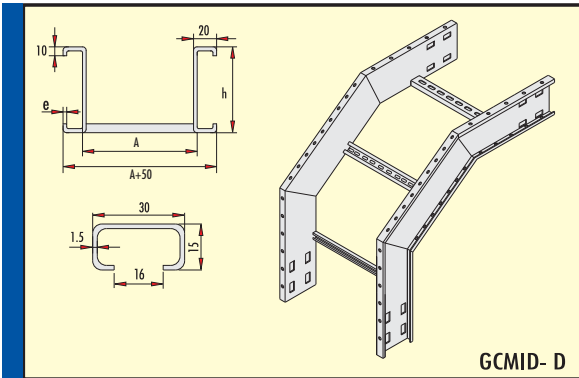

Dış Bükü Elemanı (h=100 mm)

External Riser Element (h=100 mm)

Внешние Элементы Надст очного элемента

Sipariş kodu Order code Код заявки	Ağırlık (Kg/ad.) Weight (Kg/unit) Вес (кг/шт)	A mm	e mm	h mm	Price list прайс-лист шт./у.е.	
					Pre-Galvanized Предв. Цинк-ия	Hot dip Galvanized гор.оцинк. HDZ
GCMID-20 300R D	3,800	200	2	100		53,20
GCMID-30 300R D	4,010	300	2	100		56,20
GCMID-40 300R D	4,220	400	2	100		59,10
GCMID-50 300R D	4,420	500	2	100		62,00
GCMID-60 300R D	4,630	600	2	100		65,00

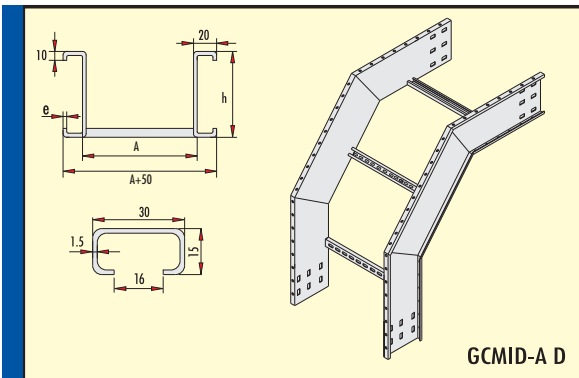

Dış Bükü Elemanı (h=150 mm)

External Riser Element (h=150 mm)

Внешние Элементы Надст очного элемента

Sipariş kodu Order code Код заявки	Ağırlık (Kg/ad.) Weight (Kg/unit) Вес (кг/шт)	A mm	e mm	h mm	Price list прайс-лист шт./у.е.	
					Pre-Galvanized Предв. Цинк-ия	Hot dip Galvanized гор.оцинк. HDZ
GCMID-A20 300R D	4,950	200	2	150		70,00
GCMID-A30 300R D	5,150	300	2	150		73,00
GCMID-A40 300R D	5,350	400	2	150		75,00
GCMID-A50 300R D	5,560	500	2	150		78,00
GCMID-A60 300R D	5,760	600	2	150		81,00

Bu Ürünler İsteğe Bağlı 450 ve 600 Radüslü Olarak İmal Edilebilir.

These products can be manufactured radius 450 and radius 600 due to request.

Эти продукты могут быть изготовленными радиусом 450 и радиусом 600 из-за request.

Kaplama : TS 914 EN ISO-1461 (BS-EN-ISO-1461) Sıcak Daldırma Galvaniz.

Coating : TS 914 EN ISO-1461 (BS-EN-ISO-1461) Hot Dip Galvanized

Bu Ürünler İsteğe Bağlı Olarak Pregalvaniz ve CORTEN-A Saçdan İmal Edilebilir.

These products can be produced from Pregalvanized or CORTEN-A Steel according to the requirements.

Talep üzerine tüm ürünler RODINO 50® malzemesi ile kaplanarak (max) 400°C ısıya, asit, tuz ve kum etkilerine karşı mukavemet sağlar.

In case of required all type of materials can be coated with RODINO 50® which will give on extra resistant at effect of 400°C heat, acid, salt and sand for the material.



AĞIR HİZMET TİPİ KABLO MERDİVENLERİ

Heavy Duty Type Cable Ladders

Сверхмощные лестничные лотки

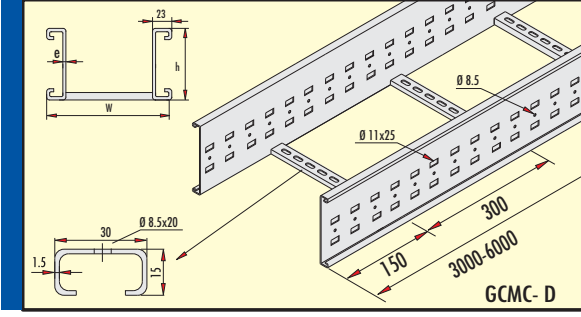

Ağır Hizmet Tipi Kablo Merdiveni (h=100mm)  
Heavy Duty Type Cable Ladder (h=100mm)

Сверхмощные лестничные лотки

Sipariş kodu Order code Код заявки	Ağırlık (Kg/mt.) Weight (Kg/mt) Вес (кг/м)	A mm	h mm	e mm	Price list прайс-лист м/у.е.	
					Pre-Galvanized Предв. Цинк-ия	Hot dip Galvanized гор.оцинк. HDZ
GCMC-20 D	5.59	200	100	2		55,90
GCMC-30 D	5.84	300	100	2		58,40
GCMC-40 D	6.10	400	100	2		61,00
GCMC-50 D	6.35	500	100	2		63,50
GCMC-60 D	6.61	600	100	2		66,10

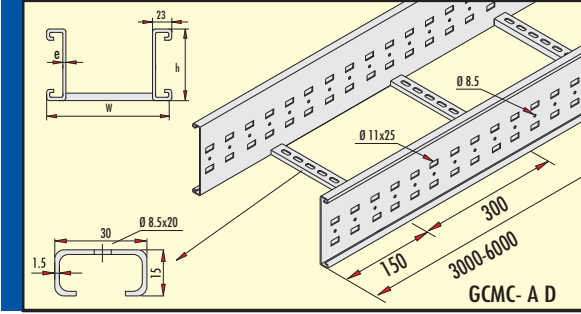

Ağır Hizmet Tipi Kablo Merdiveni (h=125mm)  
Heavy Duty Type Cable Ladder (h=125mm)

Сверхмощные лестничные лотки

Sipariş kodu Order code Код заявки	Ağırlık (Kg/mt.) Weight (Kg/mt) Вес (кг/м)	W mm	h mm	e mm	Price list прайс-лист м/у.е.	
					Pre-Galvanized Предв. Цинк-ия	Hot dip Galvanized гор.оцинк. HDZ
GCMC-A20 D	6.38	200	125	2		63,80
GCMC-A30 D	6.63	300	125	2		66,30
GCMC-A40 D	6.89	400	125	2		68,90
GCMC-A50 D	7.14	500	125	2		71,40
GCMC-A60 D	7.40	600	125	2		74,00

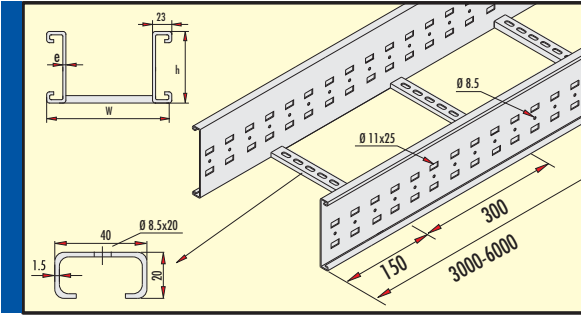

Ağır Hizmet Tipi Kablo Merdiveni (h=150mm)  
Heavy Duty Type Cable Ladder (h=150mm)

Сверхмощные лестничные лотки

Sipariş kodu Order code Код заявки	Ağırlık (Kg/mt.) Weight (Kg/mt) Вес (кг/м)	W mm	h mm	e mm	Price list прайс-лист м/у.е.	
					Pre-Galvanized Предв. Цинк-ия	Hot dip Galvanized гор.оцинк. HDZ
GCMC-B20 D	7.32	200	150	2		73,20
GCMC-B30 D	7.66	300	150	2		76,60
GCMC-B40 D	7.99	400	150	2		79,90
GCMC-B50 D	8.33	500	150	2		83,30
GCMC-B60 D	8.67	600	150	2		86,70

EK PARÇASI

Jointing Piece

Соединительные элементы

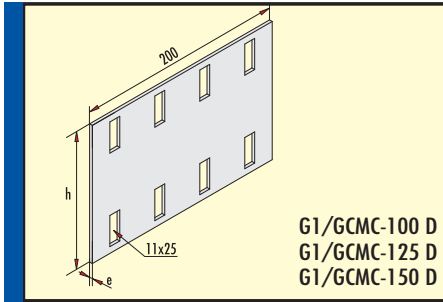

Ek Parçası Jointing Piece

Соединительные элементы

Sipariş kodu Order code Код заявки	Ağırlık (Kg/ad.) Weight (Kg/unit) Вес (кг/шт)	e mm	h mm	Price list прайс-лист шт/у.е.	
				Pre-Galvanized Предв. Цинк-ия	Hot dip Galvanized гор.оцинк. HDZ
G1/GCMC-100 D	0.260	2	83		4,16
G1/GCMC-125 D	0.339	2	108		6,24
G1/GCMC-150 D	0.417	2	133		6,67

Esti aralıkta destekleyiniz (Equal distance Support)

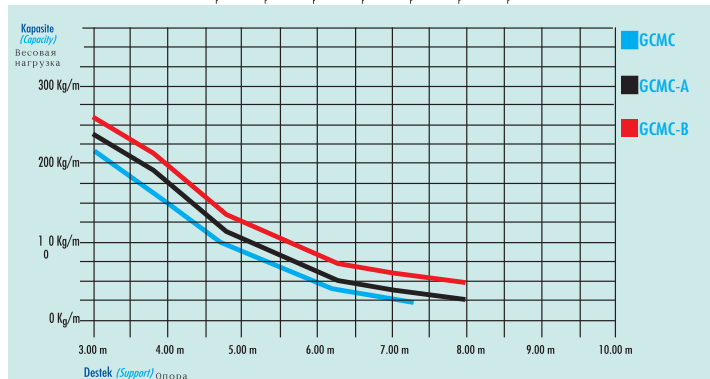

Kaplama : TS 914 EN ISO-1461 (BS-EN-ISO-1461) Sıcak Daldırma Galvaniz. Bu Ürünler İsteğe Bağlı Olarak Pregalvaniz ve CORTEN-A Saçdan İmal Edilebilir.

Coating : TS 914 EN ISO-1461 (BS-EN-ISO-1461) Hot Dip Galvanized. These products can be produced from Pregalvanized or CORTEN-A Steel according to the requirements.

Talep üzerine tüm ürünler RODINO 50® malzemesi ile kaplanarak (max) 400°C ısıya, asit, tuz ve kum etkilerine karşı mukavemet sağlar.

In case of required all type of materials can be coated with RODINO 50® which will give on extra resistant at effect of 400°C heat, acid, salt and sand for the material.

## RADÜSLÜ DÖNÜŞ ELEMANLARI

## Flat Bends

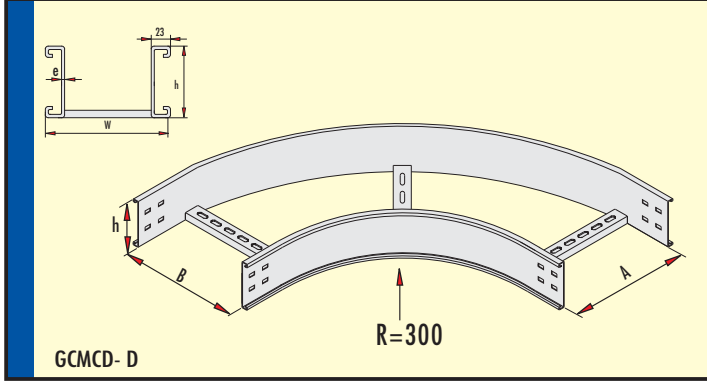

### 90° Dönüş Elemanı 90° Flat Bend

угловые элементы 90°

Sipariş kodu Order code Код заявки	Ağırlık (Kg/ad.) Weight (Kg/unit) Вес (кг / шт)	A-B mm	h mm	e mm	Price list прайс-лист шт/у.е.	
					Pre-Galvanized Предв. Цинк-ия	Hot dip Galvanized гор.оцинк. HDZ
GCMCD-10 D	5,470	100	100	2		76,60
GCMCD-20 D	6,820	200	100	2		95,50
GCMCD-30 D	7,580	300	100	2		106,15
GCMCD-40 D	8,350	400	100	2		117,00
GCMCD-50 D	9,140	500	100	2		128,00
GCMCD-60 D	10,340	600	100	2		145,80
GCMCD-A10 D	6,370	100	125	2		90,00
GCMCD-A20 D	7,220	200	125	2		101,00
GCMCD-A30 D	7,980	300	125	2		112,00
GCMCD-A40 D	8,750	400	125	2		122,50
GCMCD-A50 D	9,590	500	125	2		135,00
GCMCD-A60 D	10,740	600	125	2		150,50
GCMCD-B10 D	7,360	100	150	2		103,00
GCMCD-B20 D	8,280	200	150	2		116,00
GCMCD-B30 D	9,220	300	150	2		130,00
GCMCD-B40 D	10,550	400	150	2		148,00
GCMCD-B50 D	11,550	500	150	2		162,00
GCMCD-B60 D	12,600	600	150	2		177,00

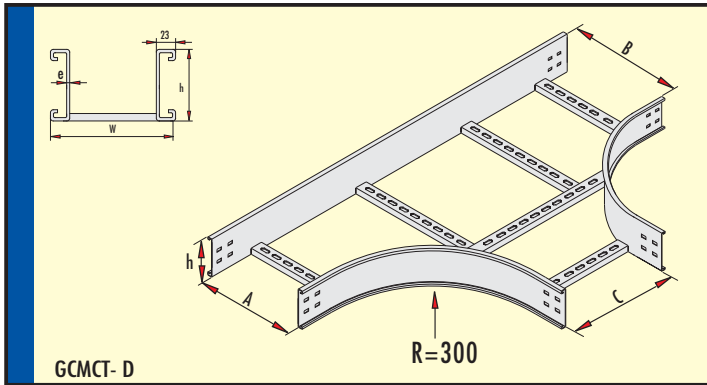

### T Bağlantı Elemanı Tees "T"

«Т» образные соединительные элементы

Sipariş kodu Order code Код заявки	Ağırlık (Kg/ad.) Weight (Kg/unit) Вес (кг / шт)	A-B-C mm	h mm	e mm	Price list прайс-лист шт/у.е.	
					Pre-Galvanized Предв. Цинк-ия	Hot dip Galvanized гор.оцинк. HDZ
GCMCT-10 D	9,110	100	100	2		127,60
GCMCT-20 D	9,710	200	100	2		136,00
GCMCT-30 D	10,530	300	100	2		148,00
GCMCT-40 D	11,210	400	100	2		157,00
GCMCT-50 D	11,880	500	100	2		166,50
GCMCT-60 D	13,020	600	100	2		182,30
GCMCT-A10 D	9,500	100	125	2		133,00
GCMCT-A20 D	10,100	200	125	2		141,50
GCMCT-A30 D	10,930	300	125	2		153,00
GCMCT-A40 D	11,610	400	125	2		162,50
GCMCT-A50 D	12,280	500	125	2		172,00
GCMCT-A60 D	13,420	600	125	2		188,90
GCMCT-B10 D	10,830	100	150	2		152,70
GCMCT-B20 D	11,560	200	150	2		162,00
GCMCT-B30 D	12,600	300	150	2		176,50
GCMCT-B40 D	13,840	400	150	2		194,80
GCMCT-B50 D	14,780	500	150	2		207,00
GCMCT-B60 D	15,720	600	150	2		220,00

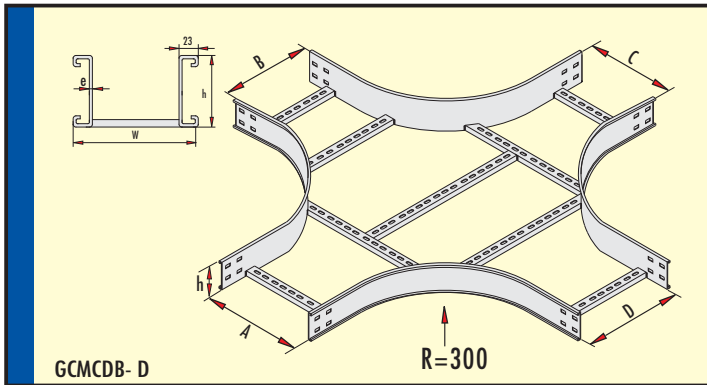

### Dörtlü Bağlantı Elemanı Crossing Element

крестообразные соединительные элементы

Sipariş kodu Order code Код заявки	Ağırlık (Kg/ad.) Weight (Kg/unit) Вес (кг / шт)	A-B-C-D mm	h mm	e mm	Price list прайс-лист шт/у.е.	
					Pre-Galvanized Предв. Цинк-ия	Hot dip Galvanized гор.оцинк. HDZ
GCMCDB-10 D	11,360	100	100	2		160,00
GCMCDB-20 D	11,740	200	100	2		165,00
GCMCDB-30 D	12,120	300	100	2		170,00
GCMCDB-40 D	12,510	400	100	2		175,20
GCMCDB-50 D	12,890	500	100	2		180,50
GCMCDB-60 D	13,270	600	100	2		186,00
GCMCDB-A10 D	11,760	100	125	2		165,00
GCMCDB-A20 D	12,140	200	125	2		170,00
GCMCDB-A30 D	12,520	300	125	2		175,50
GCMCDB-A40 D	12,910	400	125	2		181,00
GCMCDB-A50 D	13,290	500	125	2		187,00
GCMCDB-A60 D	13,670	600	125	2		192,50
GCMCDB-B10 D	13,290	100	150	2		186,00
GCMCDB-B20 D	13,900	200	150	2		194,60
GCMCDB-B30 D	14,400	300	150	2		201,60
GCMCDB-B40 D	13,310	400	150	2		187,00
GCMCDB-B50 D	15,920	500	150	2		223,00
GCMCDB-B60 D	16,520	600	150	2		231,50

Bağlantı elemanları isteğe bağlı olarak 300-450-600-900 Radüslü imal edilir.

Circler can be produced with 300-450-600-900 Radius.

Соединительные элементы по заказу можно изготовить радиусом 300-450-600-900

## RADÜSLÜ DÖNÜŞ ELEMANLARI

## Flat Bends

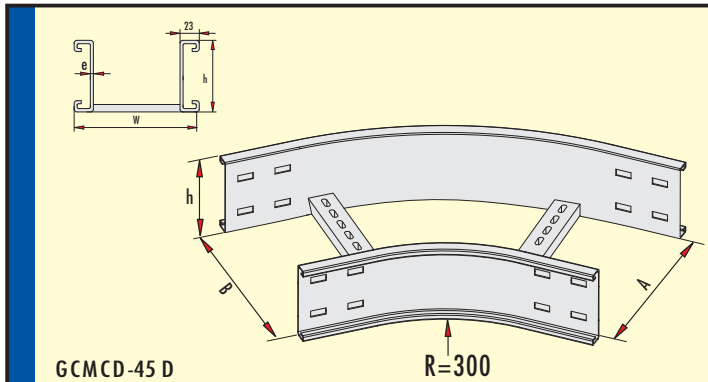
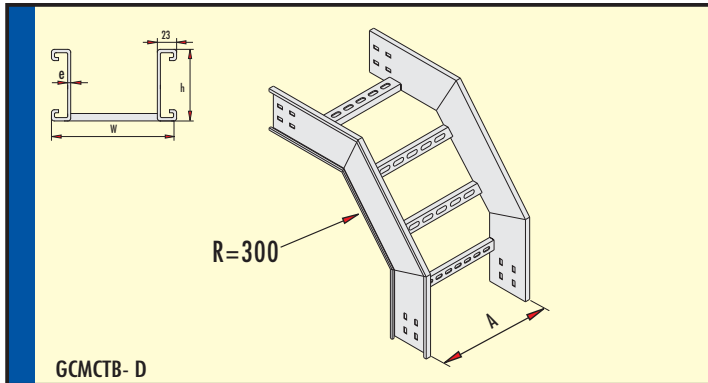
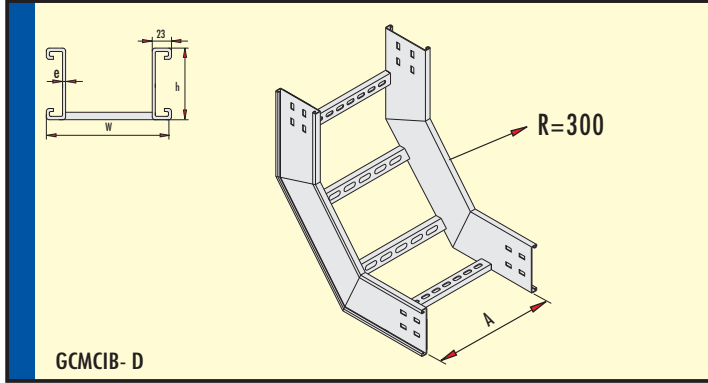

### İç Bükey Elemanı Inside Vertical Bend

Внутри и снаружи Вертикальных Изгибов

Sipariş kodu Order code Код заявки	Ağırlık (Kg/ad.) Weight (Kg/unit) Вес (кг / шт)	A mm	h mm	e mm	Price list прайс-лист шт /у.е.	
					Pre-Galvanized Предв. Цинк-ия	Hot dip Galvanized гор.оцинк. HDZ
GCMCIB-10 D	4,280	100	100	2		60,00
GCMCIB-20 D	4,590	200	100	2		64,50
GCMCIB-30 D	4,890	300	100	2		68,50
GCMCIB-40 D	5,200	400	100	2		72,80
GCMCIB-50 D	5,500	500	100	2		77,00
GCMCIB-60 D	5,810	600	100	2		81,50
GCMCIB-A10 D	4,680	100	125	2		65,50
GCMCIB-A20 D	4,990	200	125	2		70,00
GCMCIB-A30 D	5,290	300	125	2		74,00
GCMCIB-A40 D	5,600	400	125	2		78,50
GCMCIB-A50 D	5,900	500	125	2		82,60
GCMCIB-A60 D	6,210	600	125	2		87,00
GCMCIB-B10 D	5,260	100	150	2		74,00
GCMCIB-B20 D	5,560	200	150	2		78,00
GCMCIB-B30 D	5,860	300	150	2		82,00
GCMCIB-B40 D	6,170	400	150	2		86,50
GCMCIB-B50 D	6,980	500	150	2		97,80
GCMCIB-B60 D	7,380	600	150	2		103,50

### Dış Bükey Elemanı Outside Vertical Bend

Внутри и снаружи Вертикальных Изгибов

Sipariş kodu Order code Код заявки	Ağırlık (Kg/ad.) Weight (Kg/unit) Вес (кг / шт)	A mm	h mm	e mm	Price list прайс-лист шт /у.е.	
					Pre-Galvanized Предв. Цинк-ия	Hot dip Galvanized гор.оцинк. HDZ
GCMCTB-10 D	4,280	100	100	2		60,00
GCMCTB-20 D	4,590	200	100	2		64,50
GCMCTB-30 D	4,890	300	100	2		68,50
GCMCTB-40 D	5,200	400	100	2		73,00
GCMCTB-50 D	5,500	500	100	2		77,00
GCMCTB-60 D	5,810	600	100	2		82,00
GCMCTB-A10 D	4,680	100	125	2		65,50
GCMCTB-A20 D	4,940	200	125	2		70,00
GCMCTB-A30 D	5,290	300	125	2		74,00
GCMCTB-A40 D	5,600	400	125	2		78,50
GCMCTB-A50 D	5,900	500	125	2		82,60
GCMCTB-A60 D	6,210	600	125	2		87,00
GCMCTB-B10 D	5,260	100	150	2		73,70
GCMCTB-B20 D	5,560	200	150	2		78,00
GCMCTB-B30 D	5,860	300	150	2		82,00
GCMCTB-B40 D	6,170	400	150	2		86,50
GCMCTB-B50 D	6,980	500	150	2		98,00
GCMCTB-B60 D	7,380	600	150	2		103,50

### 135° Dönüş Elemanı 135° Flat Bend Element

135° Квартир Сгибают Элемент

Sipariş kodu Order code Код заявки	Ağırlık (Kg/ad.) Weight (Kg/unit) Вес (кг / шт)	A-B mm	h mm	e mm	Price list прайс-лист шт /у.е.	
					Pre-Galvanized Предв. Цинк-ия	Hot dip Galvanized гор.оцинк. HDZ
GCMCD-10-45 D	3,190	100	100	2		45,00
GCMCD-20-45 D	4,870	200	100	2		68,50
GCMCD-30-45 D	5,410	300	100	2		76,00
GCMCD-40-45 D	5,970	400	100	2		83,60
GCMCD-50-45 D	6,520	500	100	2		91,50
GCMCD-60-45 D	7,390	600	100	2		103,50
GCMCD-A10-45 D	4,550	100	125	2		63,70
GCMCD-A20-45 D	5,160	200	125	2		72,30
GCMCD-A30-45 D	5,700	300	125	2		79,80
GCMCD-A40-45 D	6,250	400	125	2		87,50
GCMCD-A50-45 D	6,850	500	125	2		95,90
GCMCD-A60-45 D	7,670	600	125	2		107,50
GCMCD-B10-45 D	5,260	100	150	2		73,70
GCMCD-B20-45 D	5,910	200	150	2		82,80
GCMCD-B30-45 D	6,590	300	150	2		92,30
GCMCD-B40-45 D	7,540	400	150	2		105,60
GCMCD-B50-45 D	8,250	500	150	2		115,50
GCMCD-B60-45 D	9,000	600	150	2		126,00

Bağlantı elemanları isteğe bağlı olarak 300-450-600-900 Radüslü imal edilir.

Circles can be produced with 300-450-600-900 Radius.

Соединительные элементы по заказу можно изготовить радиусом 300-450-600-900



## RADÜSLÜ DÖNÜŞ ELEMAN KAPAKLARI

## Flat Bend Covers

Плоских Покрытий Изгиба

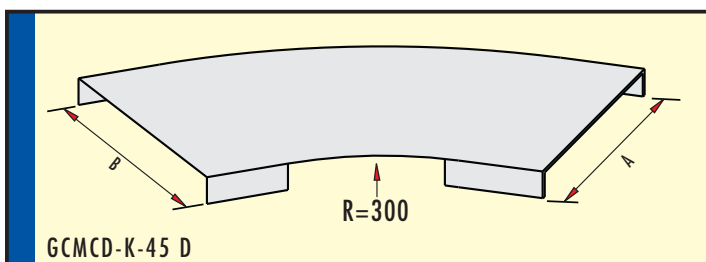
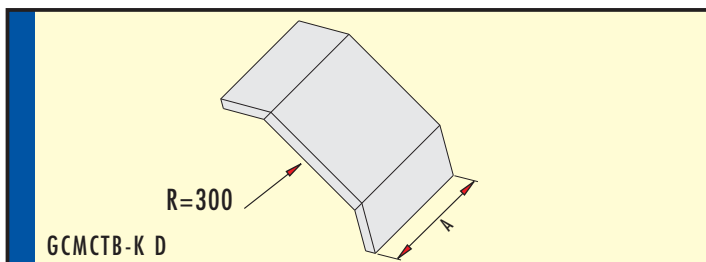
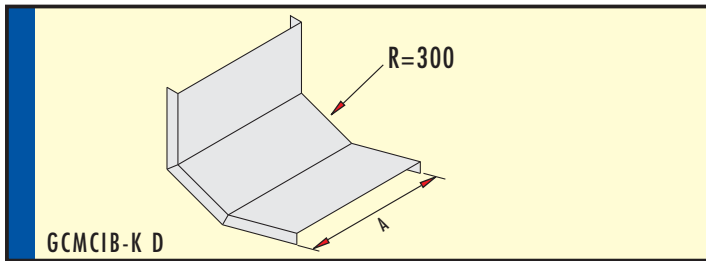
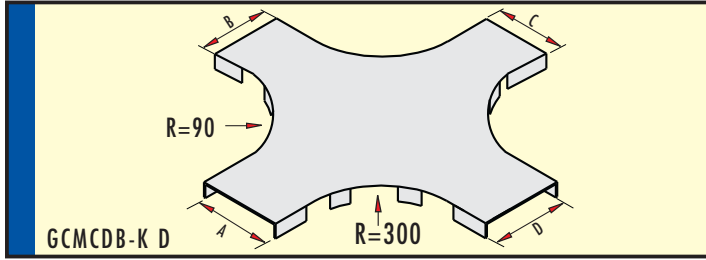
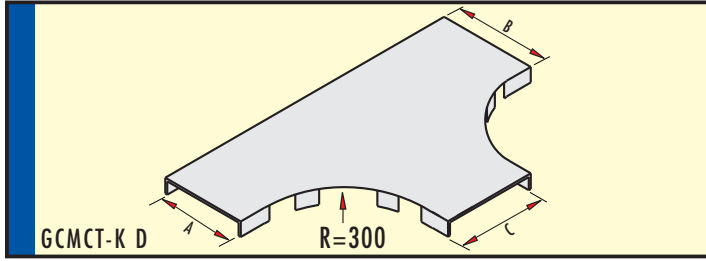
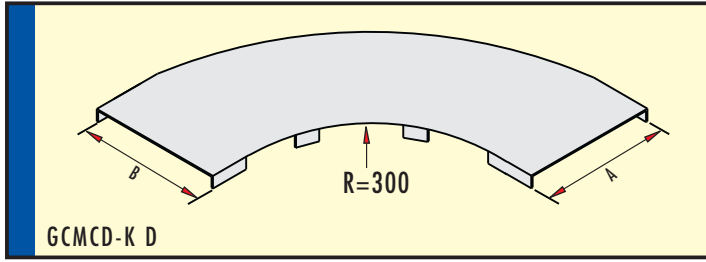

### 90° Dönüş Kapağı 90° Flat Bend Cover

Крышка для угла 90°

Sipariş kodu Order code Код заявки	Ağırlık (Kg/ad.) Weight (Kg/unit) Вес (кг/шт)	A-B mm	e mm	Price list прайс-лист шт/у.е.	
				Pre-Galvanized Предв. Цинк-ия	Hot dip Galvanized гор.оцинк. HDZ
GCMCD-10K D	0,520	150	1		7,50
GCMCD-20K D	1,100	250	1		15,50
GCMCD-30K D	1,820	350	1		25,50
GCMCD-40K D	4,050	450	1,5		56,70
GCMCD-50K D	5,550	550	1,5		77,70
GCMCD-60K D	7,300	650	1,5		102,50

### T Bağlantı Kapağı Tees "T" Cover

«Т» образные соединительные элементы

Sipariş kodu Order code Код заявки	Ağırlık (Kg/ad.) Weight (Kg/unit) Вес (кг/шт)	A-B-C mm	e mm	Price list прайс-лист шт/у.е.	
				Pre-Galvanized Предв. Цинк-ия	Hot dip Galvanized гор.оцинк. HDZ
GCMCT-10K D	0,830	150	1		11,70
GCMCT-20K D	1,690	250	1		23,70
GCMCT-30K D	2,740	350	1		38,40
GCMCT-40K D	5,960	450	1,5		84,60
GCMCT-50K D	8,070	550	1,5		113,00
GCMCT-60K D	9,470	650	1,5		132,60

### Dörtlü Bağlantı Kapağı Crossings Covers

Крестообразные соединительные элементы

Sipariş kodu Order code Код заявки	Ağırlık (Kg/ad.) Weight (Kg/unit) Вес (кг/шт)	A-B-C mm	e mm	Price list прайс-лист шт/у.е.	
				Pre-Galvanized Предв. Цинк-ия	Hot dip Galvanized гор.оцинк. HDZ
GCMCDB-10K D	1,090	150	1		15,30
GCMCDB-20K D	2,130	250	1		30,00
GCMCDB-30K D	3,350	350	1		47,00
GCMCDB-40K D	7,160	450	1,5		100,50
GCMCDB-50K D	9,530	550	1,5		134,00
GCMCDB-60K D	12,200	650	1,5		171,00

### İç Bükme Kapağı Inside Vertical Bend Cover

Внутри и снаружи Вертикального Покрытия Изгиба

Sipariş kodu Order code Код заявки	Ağırlık (Kg/ad.) Weight (Kg/unit) Вес (кг/шт)	A mm	e mm	Price list прайс-лист шт/у.е.	
				Pre-Galvanized Предв. Цинк-ия	Hot dip Galvanized гор.оцинк. HDZ
GCMCIB-10K D	1,200	150	1		17,00
GCMCIB-20K D	1,450	250	1		20,50
GCMCIB-30K D	2,100	350	1		29,50
GCMCIB-40K D	4,150	450	1,5		58,50
GCMCIB-50K D	5,150	550	1,5		72,50
GCMCIB-60K D	6,150	650	1,5		86,50

### Dış Bükme Kapağı Outside Vertical Bend Cover

Внутри и снаружи Вертикального Покрытия Изгиба

Sipariş kodu Order code Код заявки	Ağırlık (Kg/ad.) Weight (Kg/unit) Вес (кг/шт)	A mm	e mm	Price list прайс-лист шт/у.е.	
				Pre-Galvanized Предв. Цинк-ия	Hot dip Galvanized гор.оцинк. HDZ
GCMCTB-10K D	1,550	150	1		21,70
GCMCTB-20K D	1,750	250	1		24,50
GCMCTB-30K D	2,550	350	1		35,70
GCMCTB-40K D	5,000	450	1,5		70,00
GCMCTB-50K D	6,200	550	1,5		86,80
GCMCTB-60K D	7,400	650	1,5		103,60

### 135° Dönüş Eleman Kapağı 135° Flat Bend Element Cover

135° Квартир Стигают Покрытие Элемента

Sipariş kodu Order code Код заявки	Ağırlık (Kg/ad.) Weight (Kg/unit) Вес (кг/шт)	A-B mm	e mm	Price list прайс-лист шт/у.е.	
				Pre-Galvanized Предв. Цинк-ия	Hot dip Galvanized гор.оцинк. HDZ
GCMCD-10K-45 D	0,380	150	1		5,50
GCMCD-20K-45 D	1,040	250	1		14,60
GCMCD-30K-45 D	1,640	350	1		23,00
GCMCD-40K-45 D	2,700	450	1,5		34,00
GCMCD-50K-45 D	3,610	550	1,5		50,60
GCMCD-60K-45 D	4,650	650	1,5		65,10

Bağlantı eleman kapakları isteğe bağlı olarak 150-300-450-600-900 Radüslü imal edilir.  
Circlar bend covers can be produced with 150-300-450-600-900 Radius.

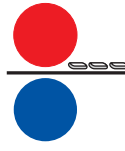

## ŞAFT KAPAĞI

## Shaft Access Cover

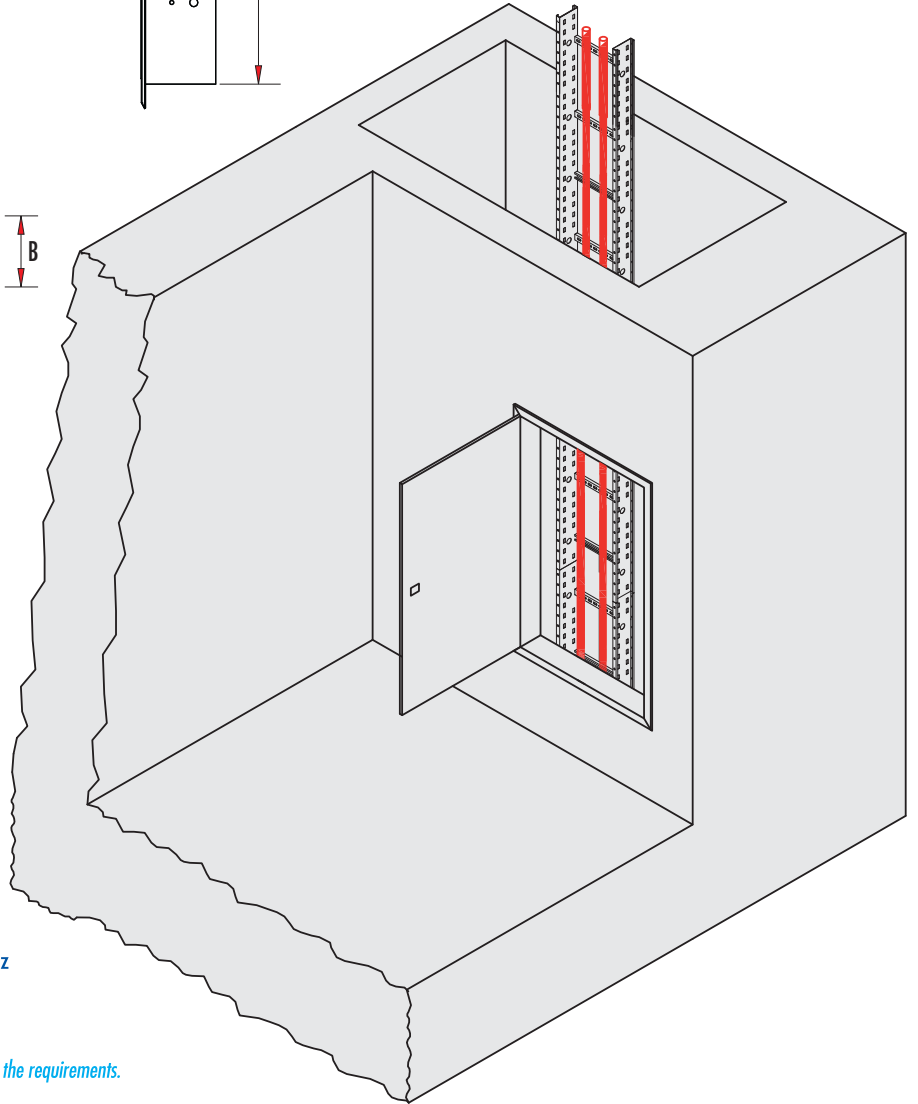
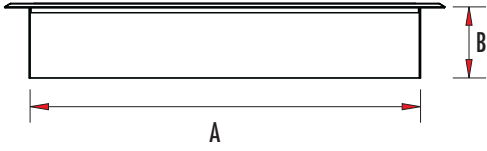
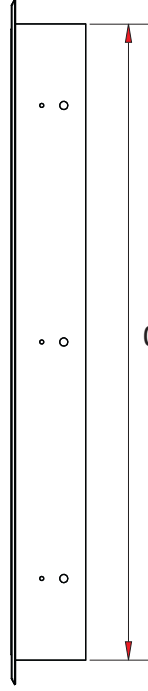
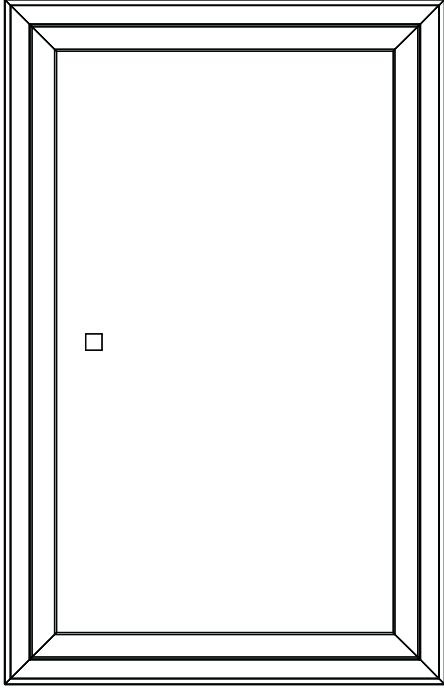

Kaplama : TS 914 EN ISO-1461 (BS-EN-ISO-1461) Sıcak Daldırma Galvaniz  
Coating : TS 914 EN ISO-1461 (BS-EN-ISO-1461) Hot Dip Galvanized

Bu Ürünler İsteğe Bağlı Olarak PREGALVANİZ ve CORTEN-A Sacdan İmal Edilebilir.  
These products can be produced from PREGALVANIZED or CORTEN-A Steel according to the requirements.

A-C-B Belirleyeceğiniz ölçülerde özel imalat yapılacaktır.  
Items will specially be manufactured due to the needed dimensions.

При необходимости комплектующие могут быть изготовлены необходимых размеров.

AĞIR HİZMET TİPİ KABLO MERDİVENLERİ

Heavy Duty Type Cable Ladders

Сверхмощные лестничные лотки

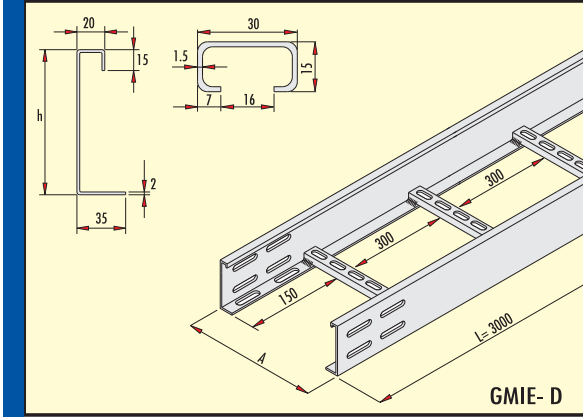

Ağır Hizmet Tipi Kablo Merdiveni

Heavy Duty Type Cable Ladder

Сверхмощные лестничные лотки

Sipariş kodu Order code Код заявки	Ağırlık (Kg/ad.) Weight (Kg/unit) Вес (кг/шт)	A mm	h mm	e mm	Price list прайс-лист М/у.е.	
					Pre-Galvanized Предв. Цинк-ия	Hot dip Galvanized гор.оцинк. HDZ
GMIE-150 D	5,750	150	100	2		57,50
GMIE-200 D	5,950	200	100	2		59,50
GMIE-300 D	6,150	300	100	2		61,50
GMIE-450 D	6,500	450	100	2		65,00
GMIE-600 D	6,800	600	100	2		68,00
GMIE-750 D	7,150	750	100	2		71,50
GMIE-900 D	7,500	900	100	2		75,00

Kaplama : TS 914 EN ISO-1461 (BS-EN-ISO-1461) Sıcak Daldırma Galvaniz.  
Bu Ürünler İsteğe Bağlı Olarak Pregalvaniz ve CORTEN-A Saçdan İmal Edilebilir.

Coating : TS 914 EN ISO-1461 (BS-EN-ISO-1461) Hot Dip Galvanized

These products can be produced from Pregalvanized or CORTEN-A Steel according to the requirements.

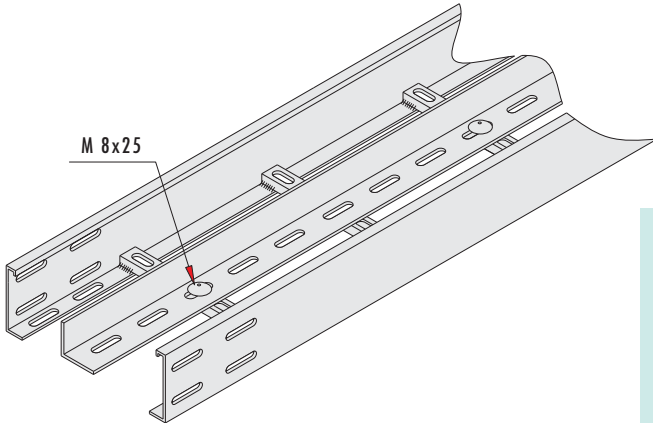
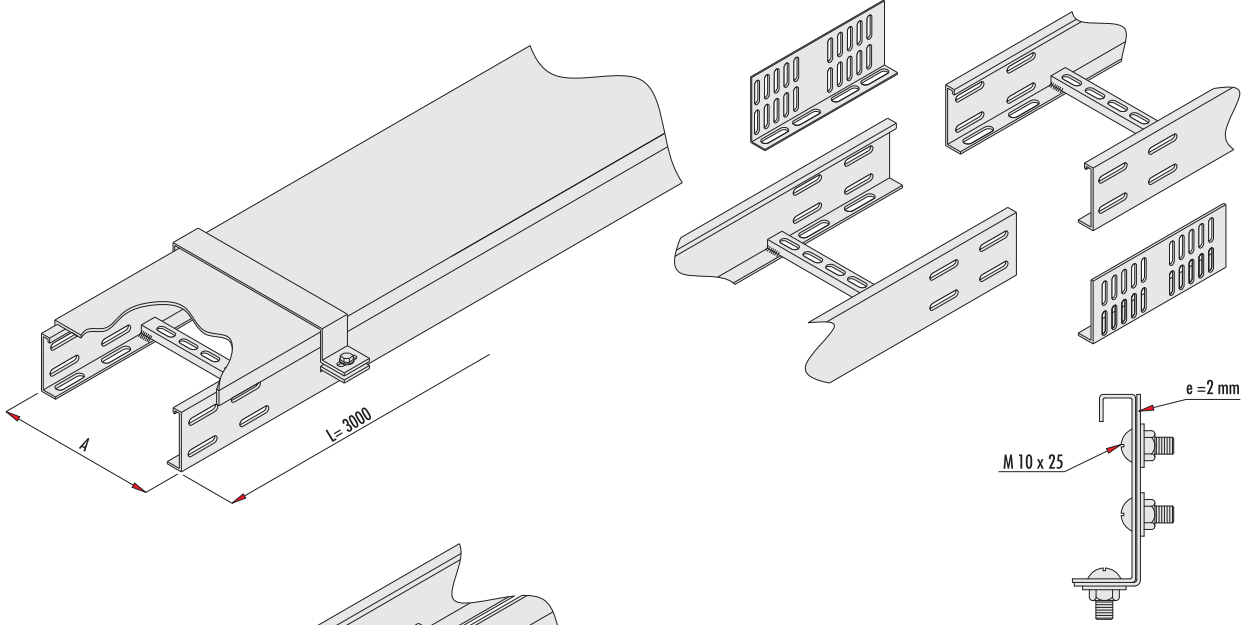

Eşit aralıklarda destekleyiniz (Equal distance Support)  
Устанавливать на равных промежутках

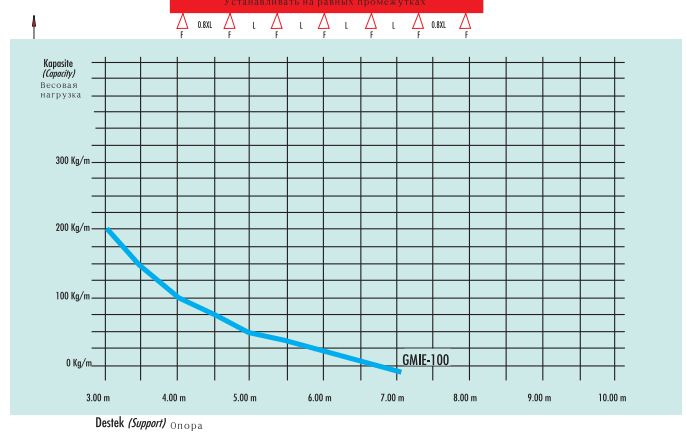

Talep üzerine tüm ürünler RODINA 50® malzemesi ile kaplanarak (max) 400°C ısıya, asit, tuz ve kum etkilerine karşı mukavemet sağlar.

In case of required all type of materials can be coated with RODINA 50® which will give on extra resistant at effect of 400°C heat, acid, salt and sand for the material.

DÖNÜŞ ELEMANLARI

Flat Bends

Плоский Изгиб

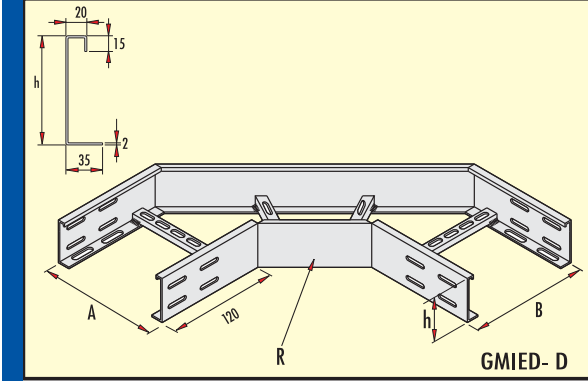

90° Dönüş Elemanı 300 Radius (h=100 mm)  
90° Flat Bend Element Radius 300 (h=100 mm)  
90° Квартир Сгибает Элемент

Sipariş kodu Order code Код заявки	Ağırlık (Kg/ad.) Weight (Kg/unit) Вес (кг/шт)	A-B mm	h mm	R mm	Price list прайс-лист шт./у.е.	
					Pre-Galvanized Предв. Цинк-ия	Hot dip Galvanized гор.оцинк. HDZ
GMIED-150 D	4,000	150	100	300		56,00
GMIED-200 D	4,250	200	100	300		59,50
GMIED-300 D	5,000	300	100	300		70,00
GMIED-450 D	6,350	450	100	300		88,90
GMIED-600 D	8,100	600	100	300		113,40
GMIED-750 D	9,100	750	100	300		127,40
GMIED-900 D	10,100	900	100	300		141,40

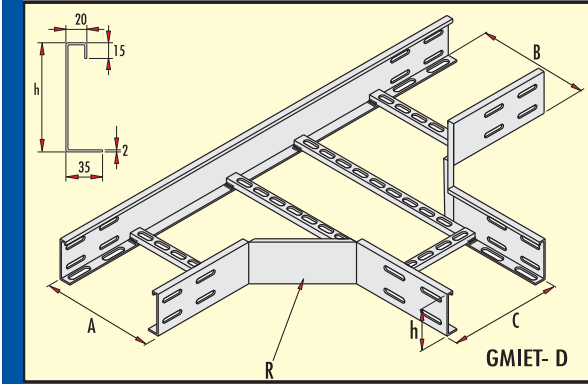

"T" Bağlantı Elemanı 300 Radius (h=100 mm)  
Tee "T" Element Radius 300 (h=100 mm)  
Мишень "Т" Квартира Сгибает Элемент

Sipariş kodu Order code Код заявки	Ağırlık (Kg/ad.) Weight (Kg/unit) Вес (кг/шт)	A-B-C mm	h mm	R mm	Price list прайс-лист шт./у.е.	
					Pre-Galvanized Предв. Цинк-ия	Hot dip Galvanized гор.оцинк. HDZ
GMIIET-150 D	5,500	150	100	300		77,00
GMIIET-200 D	5,800	200	100	300		81,20
GMIIET-300 D	6,400	300	100	300		89,60
GMIIET-450 D	7,400	450	100	300		103,60
GMIIET-600 D	9,400	600	100	300		131,60
GMIIET-750 D	10,400	750	100	300		145,60
GMIIET-900 D	11,400	900	100	300		159,60

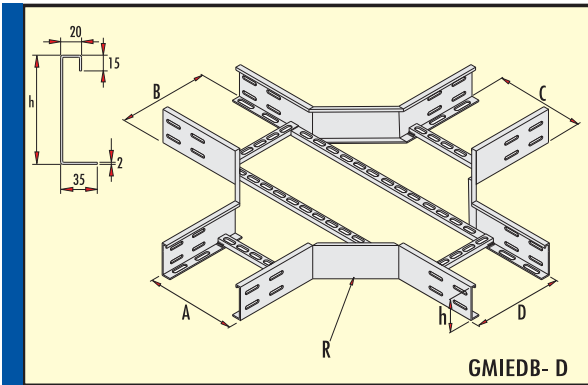

Dörtlü Bağlantı Elemanı 300 Radius (h=100 mm)  
Crossing Element Radius 300 (h=100 mm)  
Пересечение Элемента

Sipariş kodu Order code Код заявки	Ağırlık (Kg/ad.) Weight (Kg/unit) Вес (кг/шт)	A-B-C-D mm	h mm	R mm	Price list прайс-лист шт./у.е.	
					Pre-Galvanized Предв. Цинк-ия	Hot dip Galvanized гор.оцинк. HDZ
GMIEDB-150 D	6,600	150	100	300		92,40
GMIEDB-200 D	6,800	200	100	300		95,20
GMIEDB-300 D	7,200	300	100	300		100,80
GMIEDB-450 D	8,850	450	100	300		123,90
GMIEDB-600 D	10,500	600	100	300		147,00
GMIEDB-750 D	11,500	750	100	300		161,00
GMIEDB-900 D	12,500	900	100	300		175,00

Kaplama : TS 914 EN ISO-1461 (BS-EN-ISO-1461) Sıcak Daldırma Galvaniz.

Coating : TS 914 EN ISO-1461 (BS-EN-ISO-1461) Hot Dip Galvanized

Bu Ürünler İsteğe Bağlı Olarak Pregalvaniz ve CORTEN-A Saçdan İmal Edilebilir.

These products can be produced from Pregalvanized or CORTEN-A Steel according to the requirements.

Talep üzerine tüm ürünler RODINA 50® malzemesi ile kaplanarak (max) 400°C ısıya, asit, tuz ve kum etkilerine karşı mukavemet sağlar.

In case of required all type of materials can be coated with RODINA 50® which will give on extra resistant at effect of 400°C heat, acid, salt and sand for the material.



AĞIR HİZMET TİP KABLO KANALLARI *Heavy Duty Type Cable Trays*

Тяжелые Подносы Кабеля Типа Обязанности

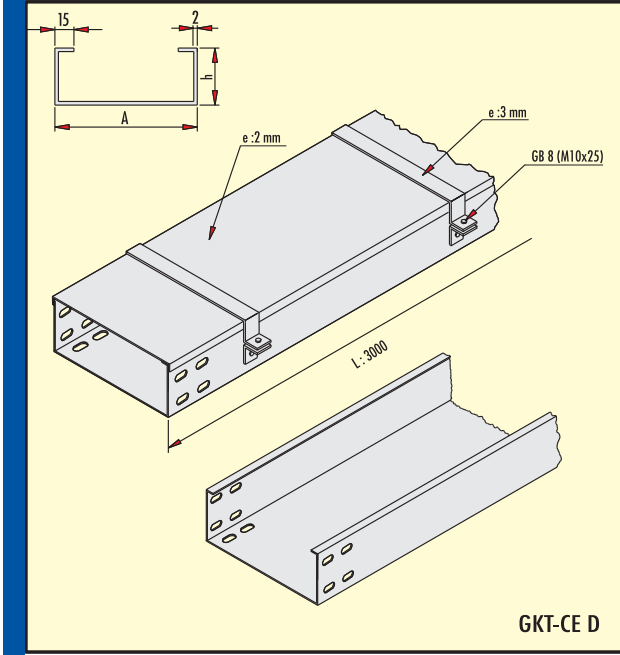

Ağır Hizmet Tip Kablo Kanalı  
*Heavy Duty Type Cable Tray*

Тяжелые Подносы Кабеля Типа Обязанности

Sipariş kodu Order code Код заявки	Ağırlık (Kg/m.) Weight (Kg/m) Вес (кг/м)	A mm	h mm	Price list прайс-лист М/у.е.	
				Pre-Galvanized Предв. Цинк-ия	Hot dip Galvanized гор.оцинк. HDZ
GKT-CE 150 D	10,540	150	100		105,40
GKT-CE 200 D	11,430	200	100		114,30
GKT-CE 300 D	14,750	300	100		147,50
GKT-CE 450 D	19,730	450	100		197,30
GKT-CE 600 D	24,710	600	100		247,10
GKT-CE 750 D	29,540	750	100		295,40
GKT-CE 900 D	34,520	900	100		345,20

Not: Bu kodlara kapak ve kapak kelepçesi dahildir.

Note: Covers and cover clamps are included to the above reference codes.

Отметьте: Покртия и моллюск покрытия после включенный в вышеупомянутые коды ссылки.

EK PARÇASI *Joining Piece* Соединительные элементы

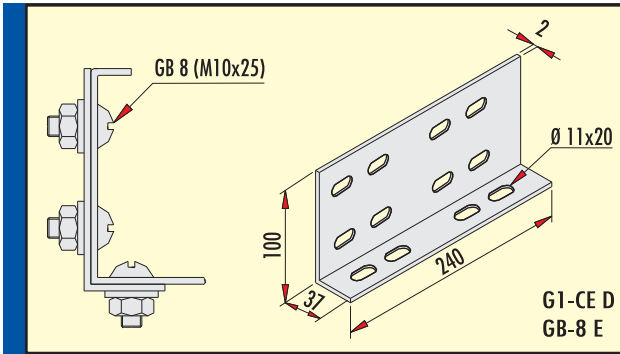

Ek Parçası *Joining Piece*

Соединительные элементы

Sipariş kodu Order code Код заявки	Ağırlık (Kg/ad.) Weight (Kg/unit) Вес (кг/шт)	Price list прайс-лист шт/у.е.	
		Pre-Galvanized Предв. Цинк-ия	Hot dip Galvanized гор.оцинк. HDZ
G1 -CE D	0,520		8,32
GB -8 E	0,020		0,40

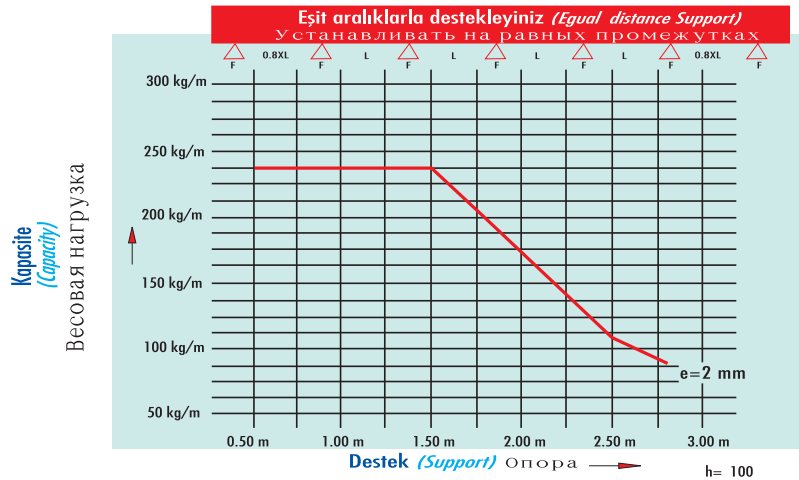

Kaplama : TS 914 EN ISO-1461 (BS-EN-ISO-1461) Sıcak Daldırma Galvaniz.  
Bu ürünler isteğe Bağlı Olarak Pregalvaniz ve CORTEN-A Saçdan İmal Edilebilir.

Coating : TS 914 EN ISO-1461 (BS-EN-ISO-1461) Hot Dip Galvanized  
These products can be produced from Pregalvanized or CORTEN-A Steel according to the requirements.

Talep üzerine tüm ürünler RODINA 50® malzemesi ile kaplanarak (max) 400°C ısıya, asit, tuz ve kum etkilerine karşı mukavemet sağlar.

In case of required all type of materials can be coated with RODINA 50® which will give on extra resistant at effect of 400°C heat, acid, salt and sand for the material.

DÖNÜŞ ELEMANLARI

Flat Bends

Плоский Изгиб

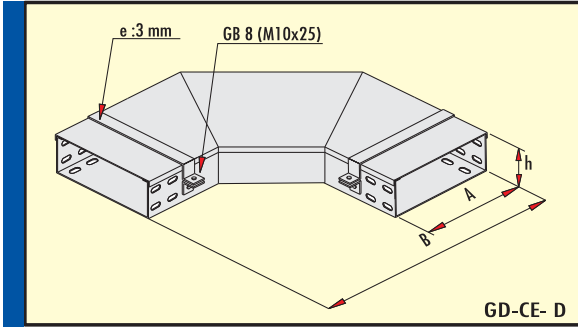

90° Dönüş Elemanı 300 Radius (h=100 mm)  
90° Flat Bend Element Radius 300 (h=100 mm)  
90° Квартир Стибают Элемент

Sipariş kodu Order code Код заявки	Ağırlık (Kg/ad.) Weight (Kg/unit) Вес (кг/шт)	A mm	B mm	e mm	h mm	R mm	Price list прайс-лист шт./у.е.	
							Pre-Galvanized Предв. Цинк-ия	Hot dip Galvanized гор.оцинк. HDZ
GD-CE- 150 D	8,400	150	150	2	100	300		117,60
GD-CE- 200 D	10,300	200	200	2	100	300		144,20
GD-CE- 300 D	14,600	300	300	2	100	300		204,40
GD-CE- 450 D	21,900	450	450	2	100	300		306,60
GD-CE- 600 D	30,360	600	600	2	100	300		425,04
GD-CE- 750 D	41,760	750	750	2	100	300		584,64
GD-CE- 900 D	52,820	900	900	2	100	300		739,48

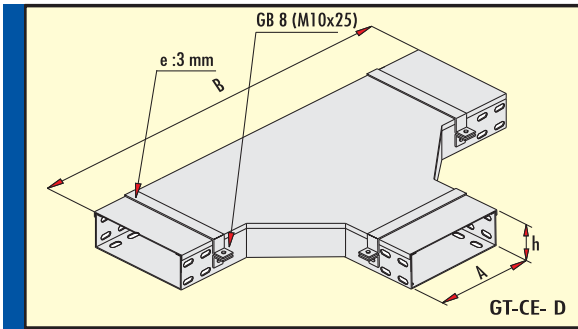

"T" Bağlantı Elemanı 300 Radius (h=100 mm)  
Tee "T" Element Radius 300 (h=100 mm)  
Мишень "Т" Квартира Стибают Элемент

Sipariş kodu Order code Код заявки	Ağırlık (Kg/ad.) Weight (Kg/unit) Вес (кг/шт)	A mm	B mm	e mm	h mm	R mm	Price list прайс-лист шт./у.е.	
							Pre-Galvanized Предв. Цинк-ия	Hot dip Galvanized гор.оцинк. HDZ
GT-CE- 150 D	14,350	150	1000	2	100	300		200,90
GT-CE- 200 D	16,900	200	1050	2	100	300		236,60
GT-CE- 300 D	23,100	300	1150	2	100	300		323,40
GT-CE- 450 D	33,600	450	1300	2	100	300		470,40
GT-CE- 600 D	45,300	600	1450	2	100	300		634,20
GT-CE- 750 D	61,130	750	1600	2	100	300		855,82
GT-CE- 900 D	76,600	900	1750	2	100	300		1072,40

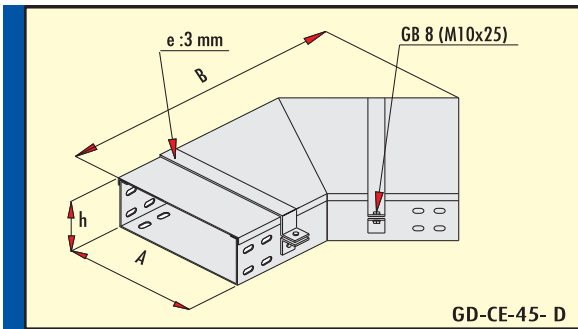

135° Dönüş Elemanı 135° Flat Bend Element  
135° Квартир Стибают Элемент

Sipariş kodu Order code Код заявки	Ağırlık (Kg/ad.) Weight (Kg/unit) Вес (кг/шт)	A mm	B mm	e mm	h mm	Price list прайс-лист шт./у.е.	
						Pre-Galvanized Предв. Цинк-ия	Hot dip Galvanized гор.оцинк. HDZ
GD-CE-45 150 D	5,800	150	532	2	100		81,20
GD-CE-45 200 D	7,900	200	576	2	100		110,60
GD-CE-45 300 D	9,700	300	638	2	100		135,80
GD-CE-45 450 D	11,270	450	744	2	100		157,78
GD-CE-45 600 D	19,100	600	850	2	100		267,40
GD-CE-45 750 D	25,580	750	956	2	100		358,12
GD-CE-45 900 D	32,000	900	1062	2	100		448,00

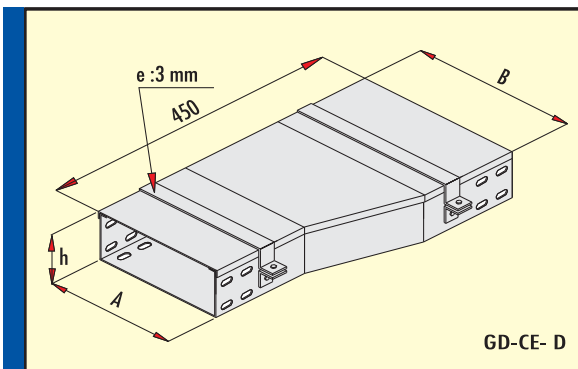

Redüksiyon Reducer  
Редуктор

Sipariş kodu Order code Код заявки	Ağırlık (Kg/ad.) Weight (Kg/unit) Вес (кг/шт)	A mm	B mm	e mm	h mm	Price list прайс-лист шт./у.е.	
						Pre-Galvanized Предв. Цинк-ия	Hot dip Galvanized гор.оцинк. HDZ
GD-CE-20/30 D	6,710	200	300	2	100		93,94
GD-CE-20/45 D	8,170	200	450	2	100		114,38
GD-CE-20/60 D	9,700	200	600	2	100		135,80
GD-CE-20/75 D	11,200	200	750	2	100		156,80
GD-CE-20/90 D	12,750	200	900	2	100		178,50
GD-CE-30/45 D	8,880	300	450	2	100		124,32
GD-CE-30/60 D	10,370	300	600	2	100		145,18
GD-CE-30/75 D	11,900	300	750	2	100		166,60
GD-CE-30/90 D	12,320	300	900	2	100		172,48
GD-CE-45/60 D	11,450	450	600	2	100		160,30
GD-CE-45/75 D	12,950	450	750	2	100		181,30
GD-CE-45/90 D	14,430	450	900	2	100		202,02
GD-CE-60/75 D	14,000	600	750	2	100		196,00
GD-CE-60/90 D	15,480	600	900	2	100		216,72
GD-CE-75/90 D	16,560	750	900	2	100		231,84

Kaplama : TS 914 EN ISO-1461 (BS-EN-ISO-1461) Sıcak Daldırma Galvaniz.

Coating : TS 914 EN ISO-1461 (BS-EN-ISO-1461) Hot Dip Galvanized

Bu ürünler isteğe Bağlı Olarak Pregalvaniz ve CORTEN-A Saçdan İmal Edilebilir.

These products can be produced from Pregalvanized or CORTEN-A Steel according to the requirements.

Talep üzerine tüm ürünler RODINA 50® malzemesi ile kaplanarak (max) 400°C ısıya, asit, tuz ve kum etkilerine karşı mukavemet sağlar.

In case of required all type of materials can be coated with RODINA 50® which will give on extra resistant at effect of 400°C heat, acid, salt and sand for the material.

KABLO MERDİVENLERİ

Cable Ladders

лестничные лотки

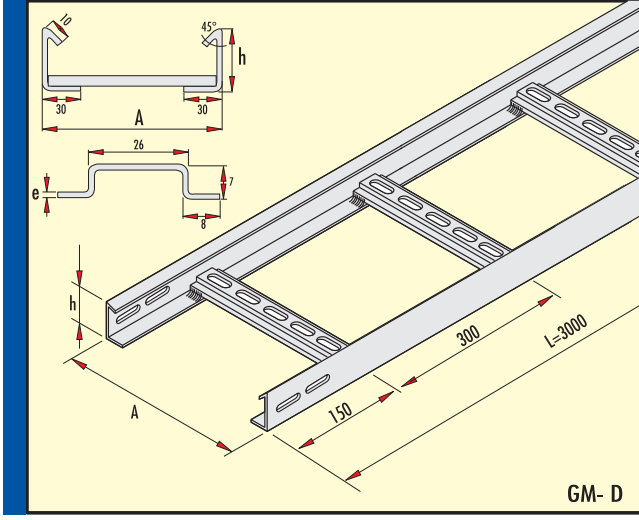

Kablo Merdiveni  
Cable Ladder

лестничные лотки

Sipariş kodu Order code Код заявки	Ağırlık (Kg/mt.) Weight (Kg/mt) Вес (кг/м)	A mm	h mm	e mm	Price list прайс-лист М/у.е.	
					Pre-Galvanized Предв. Цинк-ия	Hot dip Galvanized гор.оцинк. HDZ
GM-10 D	2,350	100	50	1,5		23,50
GM-20 D	2,500	200	50	1,5		25,00
GM-30 D	2,650	300	50	1,5		26,50
GM-40 D	3,600	400	50	2		36,00
GM-50 D	3,750	500	50	2		37,50
GM-60 D	3,900	600	50	2		39,00
GM-B10 D	2,500	100	60	1,5		25,00
GM-B20 D	2,600	200	60	1,5		26,00
GM-B30 D	2,800	300	60	1,5		28,00
GM-B40 D	3,900	400	60	2		39,00
GM-B50 D	4,050	500	60	2		40,50
GM-B60 D	4,300	600	60	2		43,00

EK PARÇASI

Jointing Piece

Соединительные элементы

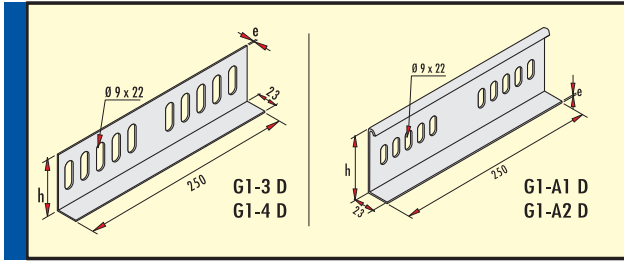

Ek Parçası Jointing Piece

Соединительные элементы

Sipariş kodu Order code Код заявки	Ağırlık (Kg/ad.) Weight (Kg/unit) Вес (кг/шт)	h mm	e mm	Price list прайс-лист ШТ/у.е.	
				Pre-Galvanized Предв. Цинк-ия	Hot dip Galvanized гор.оцинк. HDZ
G1 - 3 D	0,240	50	2		3,36
G1 - 4 D	0,270	60	2		3,80
G1 - A1 D	0,300	54	2		4,20
G1 - A2 D	0,330	64	2		4,60

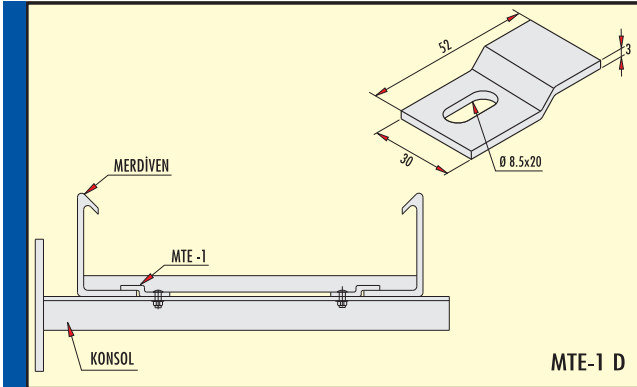

Merdiven Duvara ve Konsola Tespit Elemanı  
Ladder Fixing unit For Wall and Bracket

дементы крепления лестницы к стене и к консоли

Sipariş kodu Order code Код заявки	Ağırlık (Kg/ad.) Weight (Kg/unit) Вес (кг/шт)	e mm	Price list прайс-лист ШТ/у.е.	
			Pre-Galvanized Предв. Цинк-ия	Hot dip Galvanized гор.оцинк. HDZ
MTE - 1 D	0,037	3		0,75

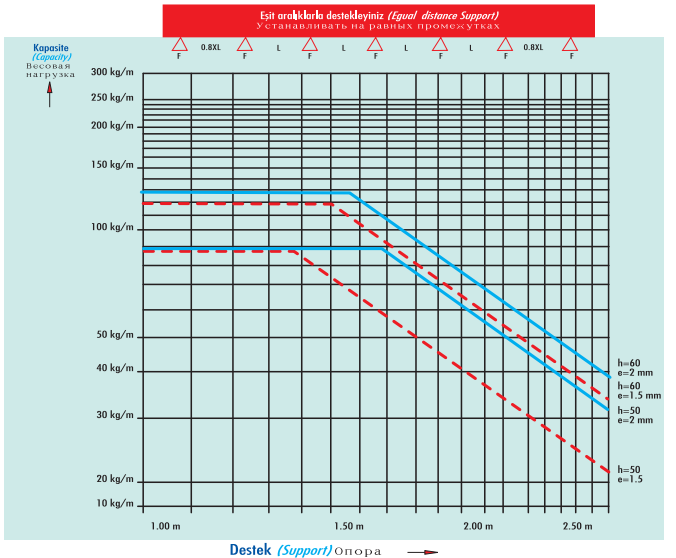

Kaplama : TS 914 EN ISO-1461 (BS-EN-ISO-1461) Sıcak Daldırma Galvaniz.  
Bu Ürünler İsteğe Bağlı Olarak Pregalvaniz ve CORTEN-A Saçdan İmal Edilebilir.

Coating : TS 914 EN ISO-1461 (BS-EN-ISO-1461) Hot Dip Galvanized  
These products can be produced from Pregalvanized or CORTEN-A Steel according to the requirements.

Talep üzerine tüm ürünler RODINA 50® malzemesi ile kaplanarak (max) 400°C ısıya, asit, tuz ve kum etkilerine karşı mukavemet sağlar.

In case of required all type of materials can be coated with RODINA 50® which will give an extra resistant to the effect of 400°C heat, acid, salt and sand for the material.

DÖNÜŞ ELEMANLARI

Flat Bend Elements

Плоский Изгиб

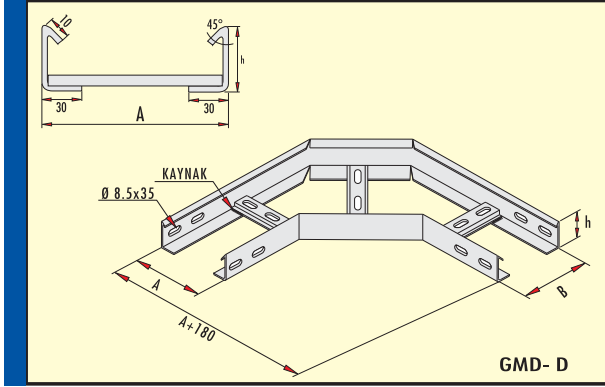

Sipariş kodu Order code Код заявки	Ağırlık (Kg/ad.) Weight (Kg/unit) Вес (кг/шт)	A-B mm	e mm	h mm	Price list прайс-лист шт./у.е.	
					Pre-Galvanized Предв. Цинк-ия	Hot dip Galvanized гор.оцинк. HDZ
					90° Dönüş Elemanı 90° Квартир Сгибают Элемент	90° Flat Bend Element
GMD-10 D	1,600	100	2	50		22,40
GMD-20 D	1,900	200	2	50		26,60
GMD-30 D	2,500	300	2	50		35,00
GMD-40 D	3,100	400	2	50		43,40
GMD-50 D	3,700	500	2	50		51,80
GMD-60 D	4,300	600	2	50		60,20
GMD-B10 D	1,800	100	2	60		25,20
GMD-B20 D	2,100	200	2	60		29,40
GMD-B30 D	2,700	300	2	60		37,80
GMD-B40 D	3,300	400	2	60		46,20
GMD-B50 D	3,900	500	2	60		54,60
GMD-B60 D	4,500	600	2	60		63,00

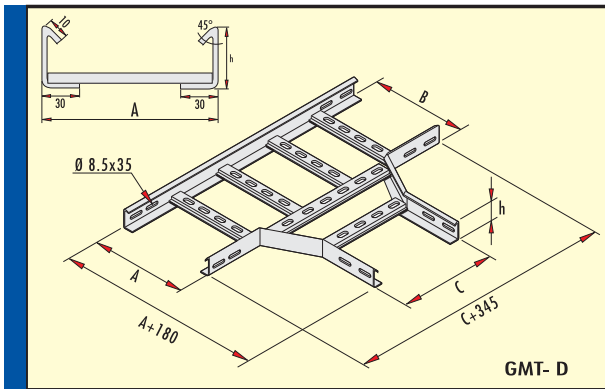

Sipariş kodu Order code Код заявки	Ağırlık (Kg/ad.) Weight (Kg/unit) Вес (кг/шт)	A-B-C mm	e mm	h mm	Price list прайс-лист шт./у.е.	
					Pre-Galvanized Предв. Цинк-ия	Hot dip Galvanized гор.оцинк. HDZ
					"T" Bağlantı Elemanı Тee "Т" Element	Мишень "Т" Квартира Сгибают Элемент
GMT-10 D	2,100	100	2	50		29,40
GMT-20 D	2,500	200	2	50		35,00
GMT-30 D	2,900	300	2	50		40,60
GMT-40 D	3,400	400	2	50		47,60
GMT-50 D	3,850	500	2	50		53,90
GMT-60 D	4,250	600	2	50		59,50
GMT-B10 D	2,250	100	2	60		31,50
GMT-B20 D	2,650	200	2	60		37,10
GMT-B30 D	3,100	300	2	60		43,40
GMT-B40 D	3,550	400	2	60		49,70
GMT-B50 D	4,000	500	2	60		56,00
GMT-B60 D	4,450	600	2	60		62,30

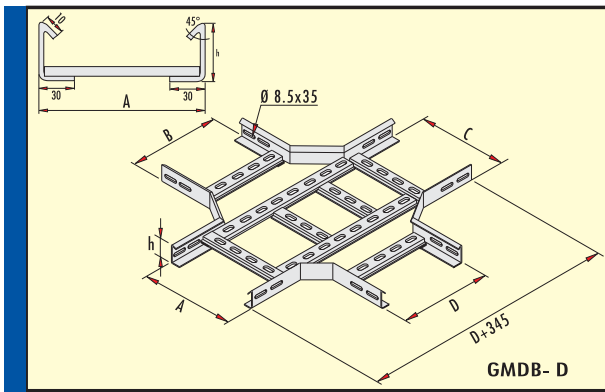

Sipariş kodu Order code Код заявки	Ağırlık (Kg/ad.) Weight (Kg/unit) Вес (кг/шт)	A-B-C mm	e mm	h mm	Price list прайс-лист шт./у.е.	
					Pre-Galvanized Предв. Цинк-ия	Hot dip Galvanized гор.оцинк. HDZ
					Dörtlü Bağlantı Elemanı Пересечение Элемента	Crossing Element
GMDB-10 D	2,400	100	2	50		33,60
GMDB-20 D	2,900	200	2	50		40,60
GMDB-30 D	3,450	300	2	50		48,30
GMDB-40 D	4,250	400	2	50		59,50
GMDB-50 D	4,900	500	2	50		68,60
GMDB-60 D	5,950	600	2	50		83,30
GMDB-B10 D	2,800	100	2	60		39,20
GMDB-B20 D	3,200	200	2	60		44,80
GMDB-B30 D	3,750	300	2	60		52,50
GMDB-B40 D	4,500	400	2	60		63,00
GMDB-B50 D	5,350	500	2	60		74,90
GMDB-B60 D	6,100	600	2	60		85,40

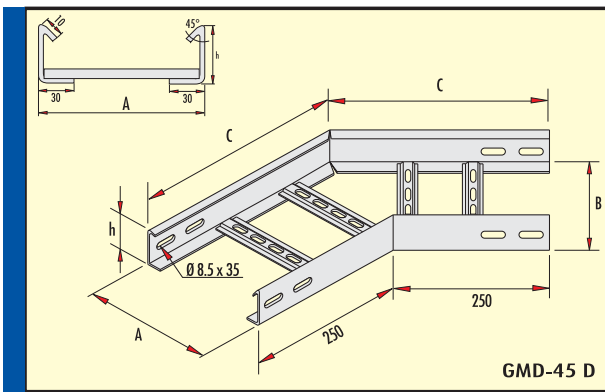

Sipariş kodu Order code Код заявки	Ağırlık (Kg/ad.) Weight (Kg/unit) Вес (кг/шт)	A-B mm	C mm	e mm	h mm	Price list прайс-лист шт./у.е.	
						Pre-Galvanized Предв. Цинк-ия	Hot dip Galvanized гор.оцинк. HDZ
						135° Dönüş Elemanı 135° Квартир Сгибают Элемент	135° Flat Bend Element
GMD-10-45 D	1,600	100	333	2	50		22,40
GMD-20-45 D	1,950	200	333	2	50		27,30
GMD-30-45 D	2,300	300	374	2	50		32,20
GMD-40-45 D	2,600	400	416	2	50		36,40
GMD-50-45 D	2,950	500	457	2	50		41,30
GMD-60-45 D	3,250	600	499	2	50		45,50
GMD-B10-45 D	1,750	100	333	2	60		24,50
GMD-B20-45 D	2,050	200	333	2	60		28,70
GMD-B30-45 D	2,400	300	374	2	60		33,60
GMD-B40-45 D	2,750	400	416	2	60		38,50
GMD-B50-45 D	3,100	500	457	2	60		43,40
GMD-B60-45 D	3,450	600	499	2	60		48,30

Kaplama : TS 914 EN ISO-1461 (BS-EN-ISO-1461) Sıcak Daldırma Galvaniz.  
Bu Ürünler İsteğe Bağlı Olarak Pregalvaniz ve CORTEN-A Saçdan İmal Edilebilir.

Coating : TS 914 EN ISO-1461 (BS-EN-ISO-1461) Hot Dip Galvanized  
These products can be produced from Pregalvanized or CORTEN-A Steel according to the requirements.

Talep üzerine tüm ürünler RODINA 50® malzemesi ile kaplanarak (max) 400°C ısıya, asit, tuz ve kum etkilerine karşı mukavemet sağlar.

In case of required all type of materials can be coated with RODINA 50® which will give on extra resistant at effect of 400°C heat, acid, salt and sand for the material.



DÖNÜŞ ELEMAN KAPAKLARI

Flat Bend Element Covers

Плоские Покртия Элемента Изгиба

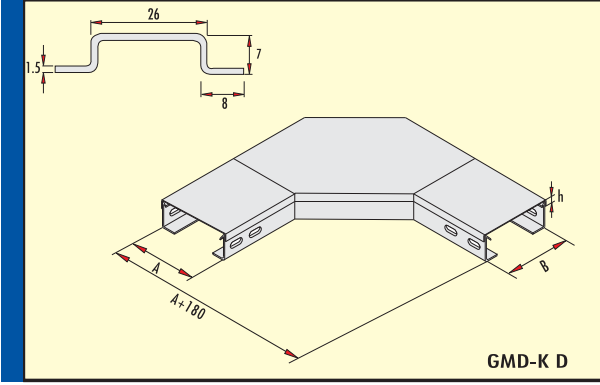

GMD-K D

90° Dönüş Eleman Kapağı 90° Flat Bend Element Cover  
90° Квартир Сгибают Элемент Покртия

Sipariş kodu Order code Код заявки	Ağırlık (Kg/ad.) Weight (Kg/unit) Вес (кг/шт)	A-B mm	e mm	h mm	Price list прайс-лист шт./у.е.	
					Pre-Galvanized Предв. Цинк-ия	Hot dip Galvanized гор.оцинк. HDZ
GMD-10K D	0,500	100	1	9		7,00
GMD-20K D	0,800	200	1	9		11,20
GMD-30K D	1,400	300	1	9		19,60
GMD-40K D	3,500	400	1,5	9		49,00
GMD-50K D	4,650	500	1,5	9		65,10
GMD-60K D	6,450	600	1,5	9		90,30

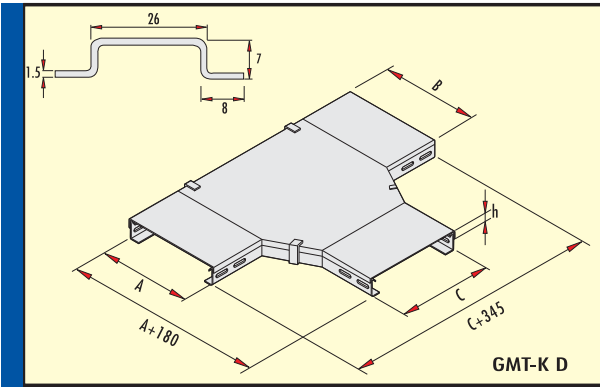

GMT-K D

"T" Bağlantı Eleman Kapağı Tee "T" Element Cover  
Мишень "Т" Квартира Сгибают Элемент Покртия

Sipariş kodu Order code Код заявки	Ağırlık (Kg/ad.) Weight (Kg/unit) Вес (кг/шт)	A-B-C mm	e mm	h mm	Price list прайс-лист шт./у.е.	
					Pre-Galvanized Предв. Цинк-ия	Hot dip Galvanized гор.оцинк. HDZ
GMT-10K D	1,000	100	1	9		14,00
GMT-20K D	1,300	200	1	9		18,20
GMT-30K D	2,150	300	1	9		30,10
GMT-40K D	4,750	400	1,5	9		66,50
GMT-50K D	6,500	500	1,5	9		91,00
GMT-60K D	8,400	600	1,5	9		117,60

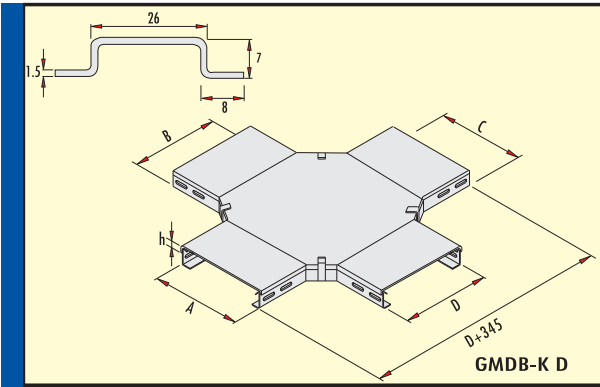

GMDB-K D

Dörtlü Bağlantı Eleman Kapağı Crossing Element Cover  
Пересечение Элемента Покртия

Sipariş kodu Order code Код заявки	Ağırlık (Kg/ad.) Weight (Kg/unit) Вес (кг/шт)	A-B-C-D mm	e mm	h mm	Price list прайс-лист шт./у.е.	
					Pre-Galvanized Предв. Цинк-ия	Hot dip Galvanized гор.оцинк. HDZ
GMDB-10K D	1,200	100	1	9		16,80
GMDB-20K D	1,700	200	1	9		23,80
GMDB-30K D	2,700	300	1	9		37,80
GMDB-40K D	6,050	400	1,5	9		84,70
GMDB-50K D	8,200	500	1,5	9		114,80
GMDB-60K D	10,600	600	1,5	9		148,40

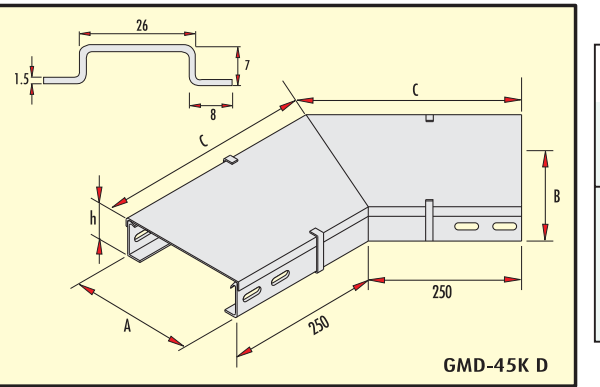

GMD-45K D

135° Dönüş Eleman Kapağı 135° Flat Bend Element Cover  
135° Квартир Сгибают Элемент Покртия

Sipariş kodu Order code Код заявки	Ağırlık (Kg/ad.) Weight (Kg/unit) Вес (кг/шт)	A-B mm	C mm	e mm	h mm	Price list прайс-лист шт./у.е.	
						Pre-Galvanized Предв. Цинк-ия	Hot dip Galvanized гор.оцинк. HDZ
GMD-10-45K D	0,800	100	333	1	9		11,20
GMD-20-45K D	1,050	200	333	1	9		14,70
GMD-30-45K D	1,600	300	374	1	9		22,40
GMD-40-45K D	3,200	400	416	1,5	9		44,80
GMD-50-45K D	4,400	500	457	1,5	9		61,60
GMD-60-45K D	5,500	600	499	1,5	9		77,00

Kaplama : TS 914 EN ISO-1461 (BS-EN-ISO-1461) Sıcak Daldırma Galvaniz. Bu Ürünler İsteğe Bağlı Olarak Pregalvaniz ve CORTEN-A Saçdan İmal Edilebilir.

Coating : TS 914 EN ISO-1461 (BS-EN-ISO-1461) Hot Dip Galvanized. These products can be produced from Pregalvanized or CORTEN-A Steel according to the requirements.

Talep üzerine tüm ürünler RODINA 50® malzemesi ile kaplanarak (max) 400°C ısıya, asit, tuz ve kum etkilerine karşı mukavemet sağlar.

In case of required all type of materials can be coated with RODINA 50® which will give on extra resistant at effect of 400°C heat, acid, salt and sand for the material.

DÖNÜŞ ELEMANLARI

Flat Bend Elements

Плоский Изгиб

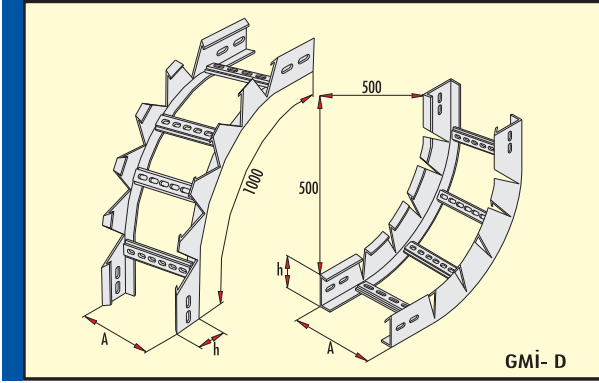

İç-Dış Büküye Bağlantılar Inside And Outside Vertical Bends  
Внутри и снаружи Вертикальных Изгибов

Sipariş kodu Order code Код заявки	Ağırlık (Kg/ad.) Weight (Kg/unit) Вес (кг/шт)	A mm	e mm	h mm	Price list прайс-лист шт./у.е.	
					Pre-Galvanized Предв. Цинк-ия	Hot dip Galvanized гор.оцинк. HDZ
GMi-10 D	2,700	100	2	50		37,80
GMi-20 D	3,000	200	2	50		42,00
GMi-30 D	3,290	300	2	50		46,06
GMi-40 D	3,500	400	2	50		49,00
GMi-50 D	3,730	500	2	50		52,22
GMi-60 D	3,900	600	2	50		54,60
GMi-B10	3,400	100	2	60		47,60
GMi-B20	3,600	200	2	60		50,40
GMi-B30	3,800	300	2	60		53,20
GMi-B40	4,000	400	2	60		56,00
GMi-B50	4,250	500	2	60		59,50
GMi-B60	4,430	600	2	60		62,02

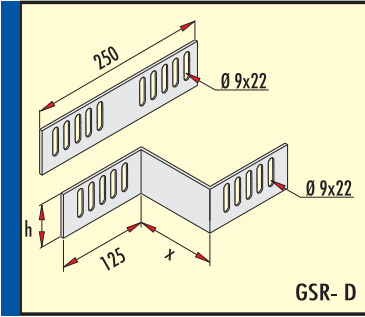

Redüksiyon X=100 mm'ye göre. Reducer

Sipariş kodu Order code Код заявки	Ağırlık (Kg/ad.) Weight (Kg/unit) Вес (кг/шт)	h mm	e mm	Price list прайс-лист шт./у.е.	
				Pre-Galvanized Предв. Цинк-ия	Hot dip Galvanized гор.оцинк. HDZ
GSR-50/100 D	0,500	50	2		7,00
GSR-60/100 D	0,600	60	2		8,40

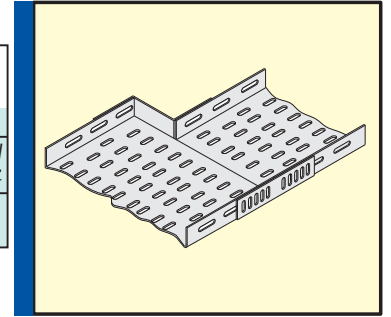

GSR redüksiyon siparişlerinde sağ veya sol redüksiyon olduğunu lütfen belirtiniz. For GSR reducer orders, please inform if you require left or right reducer.  
Для ваших заказов пожалуйста информируйте нас типу редуктора который является правым типом или левым типом.

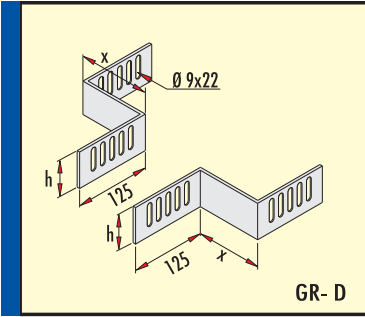

Redüksiyon X=100 mm'ye göre. Reducer

Sipariş kodu Order code Код заявки	Ağırlık (Kg/ad.) Weight (Kg/unit) Вес (кг/шт)	h mm	e mm	Price list прайс-лист шт./у.е.	
				Pre-Galvanized Предв. Цинк-ия	Hot dip Galvanized гор.оцинк. HDZ
GR-50/100 D	0,600	50	2		8,40
GR-60/100 D	0,750	60	2		10,50

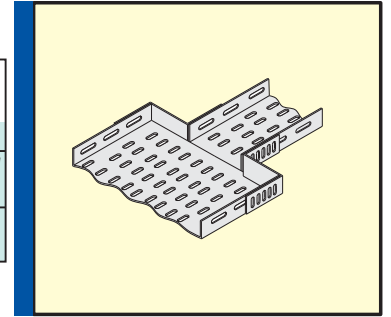

x ölçüsü değişkendir. Fiyat verilen siparişe göre belirlenecektir. Sipariş Örneği: GR-70 x=100  
Dimension "x" variable. Price will be given due to the order Ordering example  
Размер «x» изменяется. Цены могут быть указаны в зависимости от заказа.

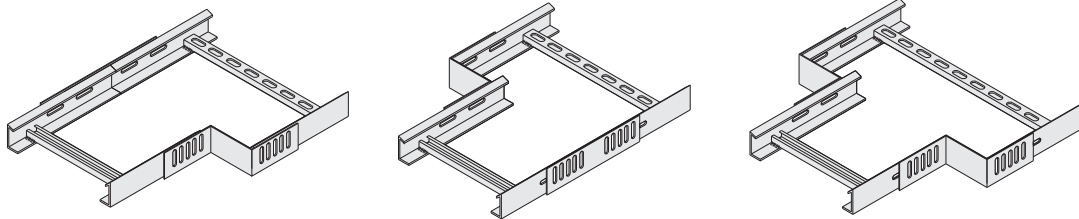

Kaplama : TS 914 EN ISO-1461 (BS-EN-ISO-1461) Sıcak Daldırma Galvaniz.  
Bu Ürünler İsteğe Bağlı Olarak Pregalvaniz ve CORTEN-A Saçdan İmal Edilebilir.

Coating : TS 914 EN ISO-1461 (BS-EN-ISO-1461) Hot Dip Galvanized  
These products can be produced from Pregalvanized or CORTEN-A Steel according to the requirements.

Talep üzerine tüm ürünler RODINA 50® malzemesi ile kaplanarak (max) 400°C ısıya, asit, tuz ve kum etkilerine karşı mukavemet sağlar.  
In case of required all type of materials can be coated with RODINA 50® which will give on extra resistant at effect of 400°C heat, acid, salt and sand for the material.

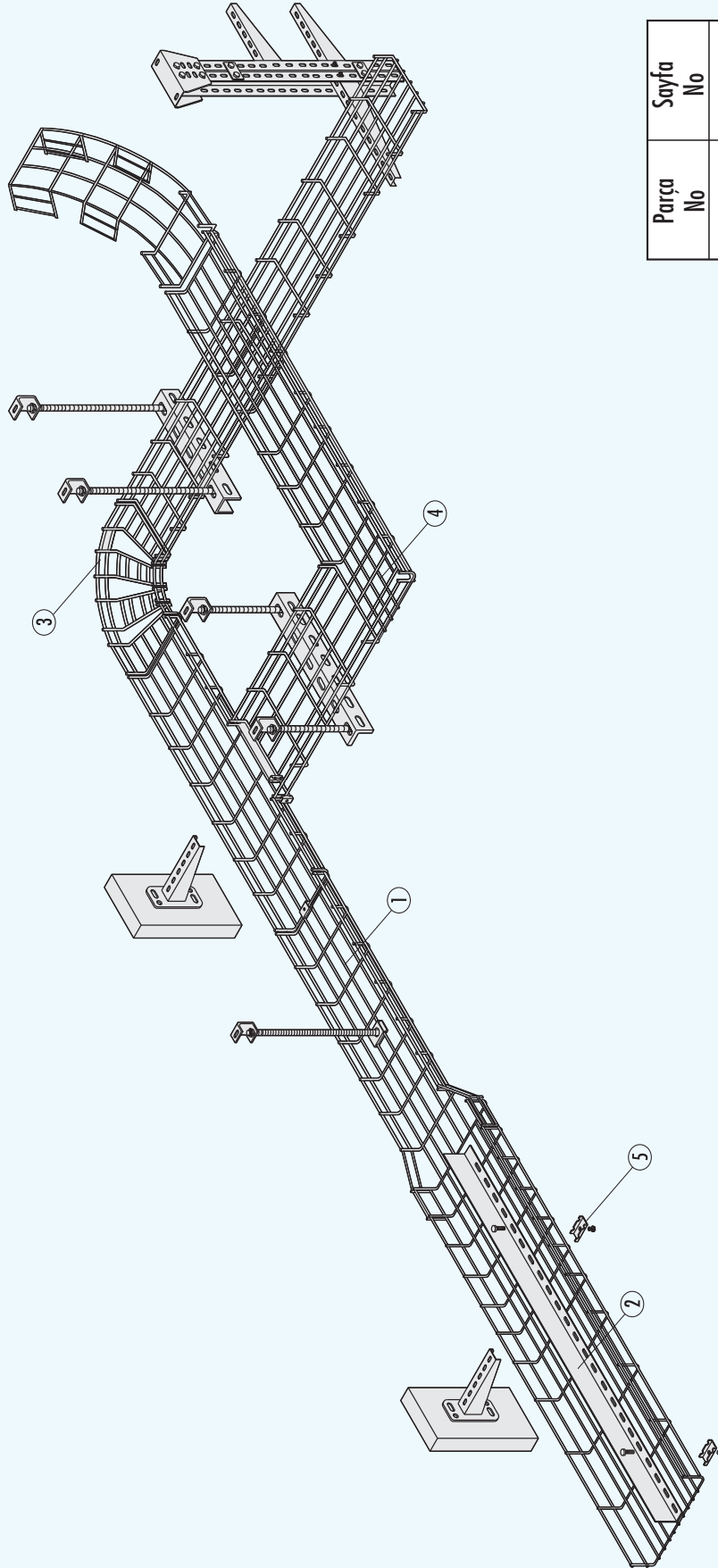
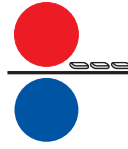

Parça No	Sayfa No
1	276
2	188
3	281
4	283
5	276

**TEL KABLO KANALLARI**

**Wire-mesh Cable Trays**

**Проволочный лоток**

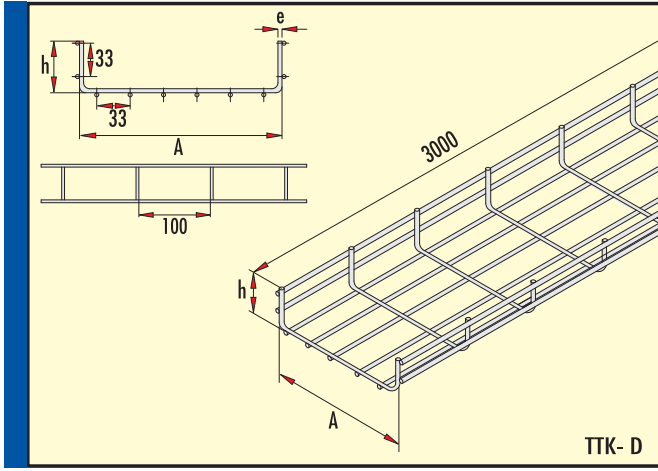

**Tel Kablo Kanalı (h=50 mm)**  
**Wire-mesh Cable Tray (h=50 mm)**  
Проволочный лоток

Sipariş kodu Order code Код заявки	Ağırlık (Kg/mt.) Weight (Kg/mt) Вес (кг/м)	A mm	h mm	e mm	Price list прайс-лист м/у.е.
TTK -10 D	0,900	100	50	4	11,00
TTK -20 D	1,300	200	50	4	16,00
TTK -30 D	1,700	300	50	4	20,50
TTK -40 D	2,100	400	50	4	25,50
TTK -50 D	2,500	500	50	4	30,00
TTK -60 D	2,940	600	50	4	35,50

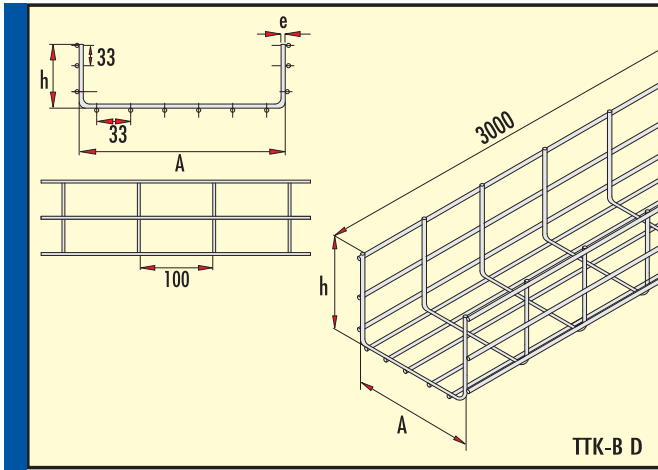

**Tel Kablo Kanalı (h=85 mm)**  
**Wire-mesh Cable Tray (h=85 mm)**  
Проволочный лоток

Sipariş kodu Order code Код заявки	Ağırlık (Kg/mt.) Weight (Kg/mt) Вес (кг/м)	A mm	h mm	e mm	Price list прайс-лист м/у.е.
TTK -B10 D	1,200	100	85	4	14,50
TTK -B20 D	1,600	200	85	4	19,50
TTK -B30 D	2,000	300	85	4	24,00
TTK -B40 D	2,400	400	85	4	29,00
TTK -B50 D	2,800	500	85	4	34,00
TTK -B60 D	3,200	600	85	4	39,00

**EK PARÇASI**

**Jointing Piece**

**Соединительные элементы**

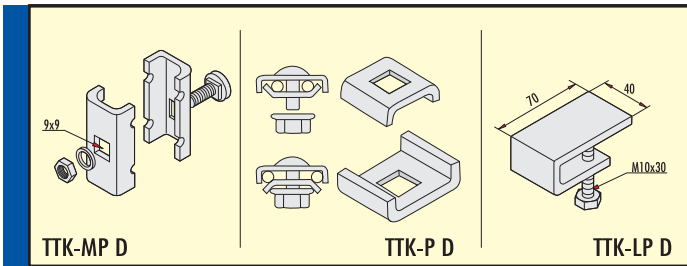

**Ek Parçası Jointing Piece**  
Соединительные элементы

Sipariş kodu Order code Код заявки	Ağırlık (Kg/ad.) Weight (Kg/unit) Вес (кг/шт)	e mm	Price list прайс-лист шт/у.е.
TTK - MP D	0,070	2	1,40
TTK - P D	0,060	2	1,20
TTK - LP D	0,300	5	5,00

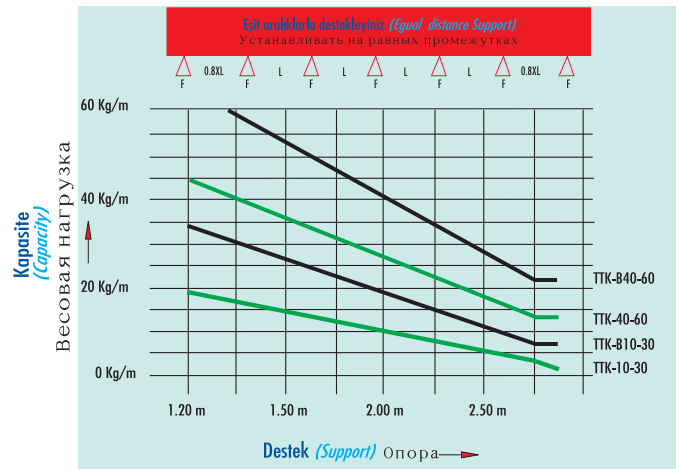

**Kaplama : TS 914 EN ISO-1461 (BS-EN-ISO-1461) Sıcak Daldırma Galvaniz. Coating : TS 914 EN ISO-1461 (BS-EN-ISO-1461) Hot Dip Galvanized**

Talep üzerine tel kablo kanallarının göz aralıklarını 50x100 mm olarak yapılmaktadır.

Talep üzerine tüm ürünler RODINA 50® malzemesi ile kaplanarak (max) 400°C ısıya, asit, tuz ve kum etkilerine karşı mukavemet sağlar.

In case of required all type of materials can be coated with RODINA 50® which will give on extra resistant at effect of 400°C heat, acid, salt and sand for the material.





TEL KABLO KANALLARI

Wire-mesh Cable Trays

Проволочный лоток

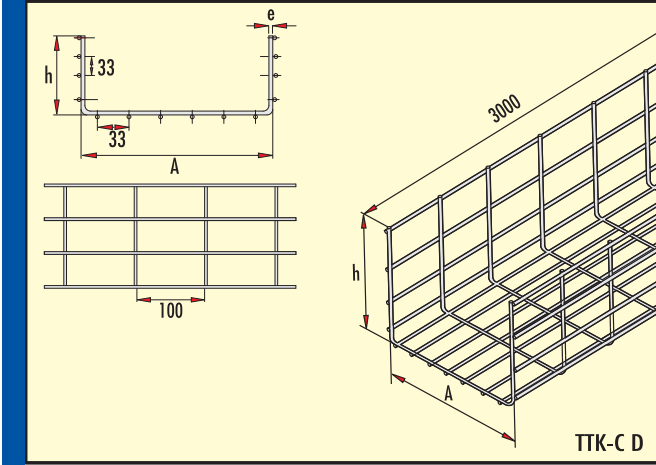

Tel Kablo Kanalı (h=120 mm)  
Wire-mesh Cable Tray (h=120 mm)

Проволочный лоток

Sipariş kodu Order code Код заявки	Ağırlık (Kg/mt.) Weight (Kg/mt) Вес (кг/м)	A mm	h mm	e mm	Price list прайс-лист М/у.е.
TTK - C 20 D	1,800	200	120	4	22,00
TTK - C 30 D	2,200	300	120	4	27,00
TTK - C 40 D	2,600	400	120	4	31,50
TTK - C 50 D	3,000	500	120	4	36,00
TTK - C 60 D	3,400	600	120	4	41,00

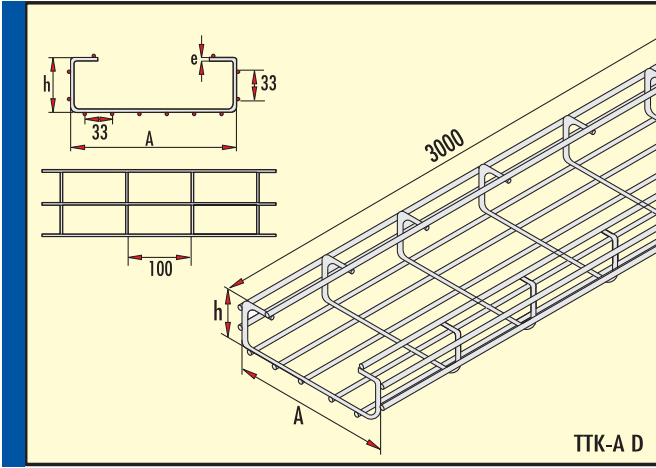

Tel Kablo Kanalı (h=60 mm)  
Wire-mesh Cable Tray (h=60 mm)

Проволочный лоток

Sipariş kodu Order code Код заявки	Ağırlık (Kg/mt.) Weight (Kg/mt) Вес (кг/м)	A mm	h mm	e mm	Price list прайс-лист М/у.е.
TTK - A 10 D	1,200	100	60	4	15,00
TTK - A 20 D	1,600	200	60	4	20,00
TTK - A 30 D	2,000	300	60	4	28,00
TTK - A 40 D	2,400	400	60	4	29,00
TTK - A 50 D	2,800	500	60	4	34,00
TTK - A 60 D	3,200	600	60	4	39,00

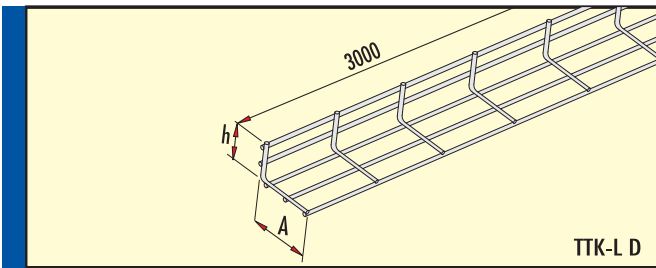

Tel Kablo Kanalı (h=60 mm)  
Wire-mesh Cable Tray (h=60 mm)

Проволочный лоток

Sipariş kodu Order code Код заявки	Ağırlık (Kg/mt.) Weight (Kg/mt) Вес (кг/м)	A mm	h mm	e mm	Price list прайс-лист М/у.е.
TTK - L D	0,650	85	50	4	8,00

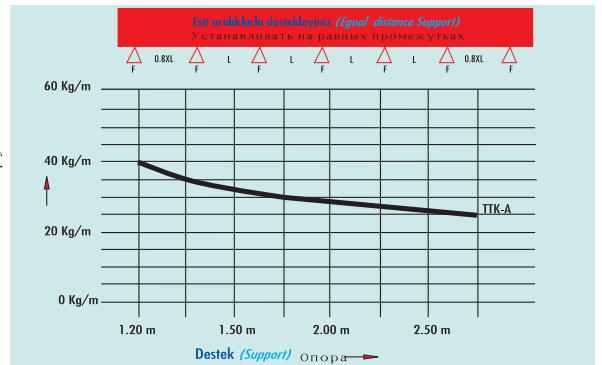
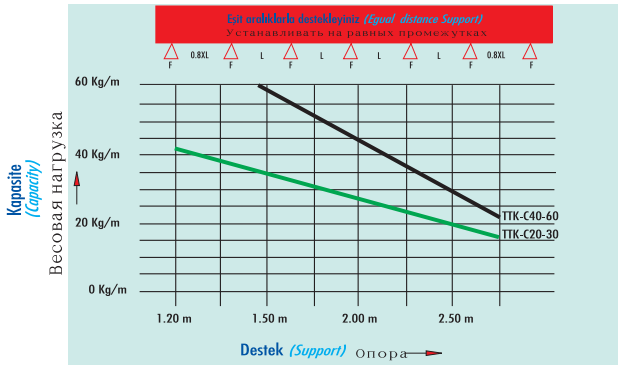

Kaplama : TS 914 EN ISO-1461 (BS-EN-ISO-1461) Sıcak Daldırma Galvaniz. Coating : TS 914 EN ISO-1461 (BS-EN-ISO-1461) Hot Dip Galvanized

Talep üzerine tel kablo kanallarının göz aralıklarını 50x100 mm olarak yapılmaktadır.

Talep üzerine tüm ürünler RODINA 50® malzemesi ile kaplanarak (max) 400°C ısıya, asit, tuz ve kum etkilerine karşı mukavemet sağlar.

In case of required all type of materials can be coated with RODINA 50® which will give on extra resistant at effect of 400°C heat, acid, salt and sand for the material.

TEL KABLO KANALLARI

Wire-mesh Cable Trays

Проволочный лоток

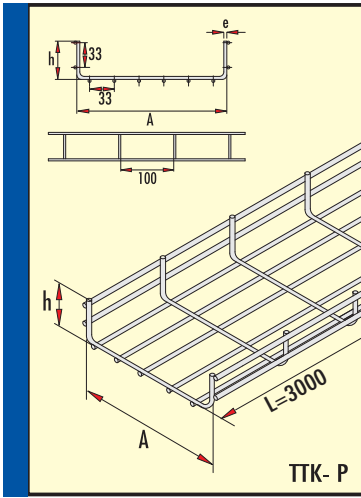

Tel Kablo Kanalı h=50 mm PASLANMAZ TEL (Cr-Ni)  
Wire-mesh Cable Tray h=50 mm Stainless Steel (Cr-Ni)  
Проволочный лоток

Sipariş kodu Order code Код заявки	Ağırlık (Kg/mt.) Weight (Kg/mt) Вес (кг/м)	A mm	h mm	e mm	Price list прайс-лист М/у.е.
TTK -10 P	0,900	100	50	4	27,00
TTK -20 P	1,300	200	50	4	39,00
TTK -30 P	1,700	300	50	4	51,00
TTK -40 P	2,100	400	50	4	63,00
TTK -50 P	2,500	500	50	4	75,00
TTK -60 P	2,940	600	50	4	88,20

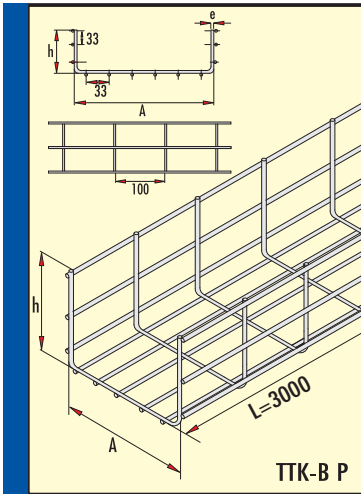
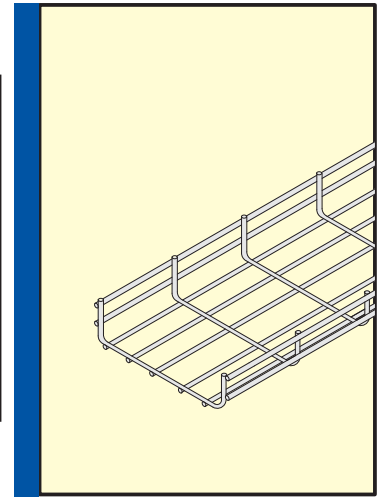

Tel Kablo Kanalı h=85 mm PASLANMAZ TEL (Cr-Ni)  
Wire-mesh Cable Tray h=85 mm Stainless Steel (Cr-Ni)  
Проволочный лоток

Sipariş kodu Order code Код заявки	Ağırlık (Kg/mt.) Weight (Kg/mt) Вес (кг/м)	A mm	h mm	e mm	Price list прайс-лист М/у.е.
TTK -B10 P	1,200	100	85	4	36,00
TTK -B20 P	1,600	200	85	4	48,00
TTK -B30 P	2,000	300	85	4	60,00
TTK -B40 P	2,400	400	85	4	72,00
TTK -B50 P	2,800	500	85	4	84,00
TTK -B60 P	3,200	600	85	4	96,00

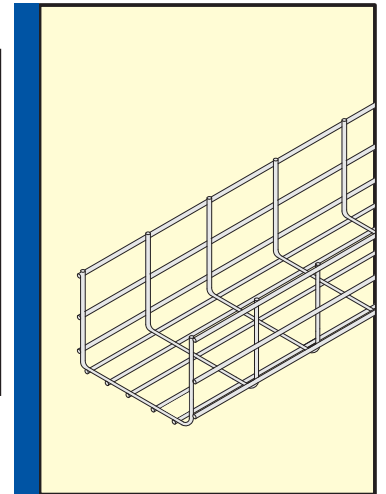

TEL KANAL KONSOLU Wire-mesh bracket

Проволочная консоль

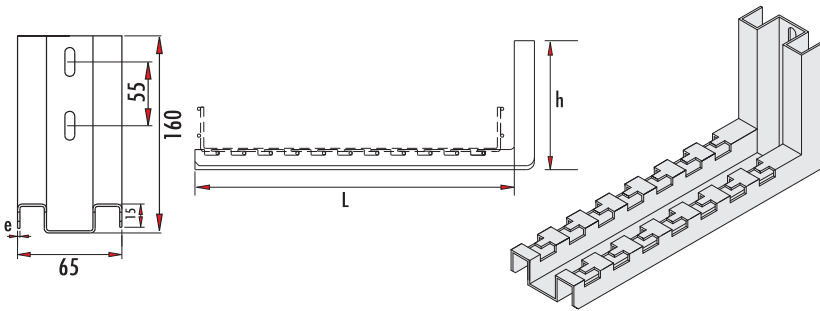

Tel Kanal Konsolu Wire-mesh bracket  
Проволочная консоль

Sipariş kodu Order code Код заявки	Ağırlık (Kg/ad.) Weight (Kg/unit) Вес (кг/шт)	L mm	e mm	Price list прайс-лист шт/у.е.
GTKD - 10 D	0,470	140	1,5	11,30
GTKD - 20 D	0,630	240	1,5	15,00
GTKD - 30 D	0,790	340	1,5	19,00
GTKD - 40 D	1,250	440	2	30,00
GTKD - 50 D	1,470	540	2	35,00
GTKD - 60 D	1,680	640	2	40,00

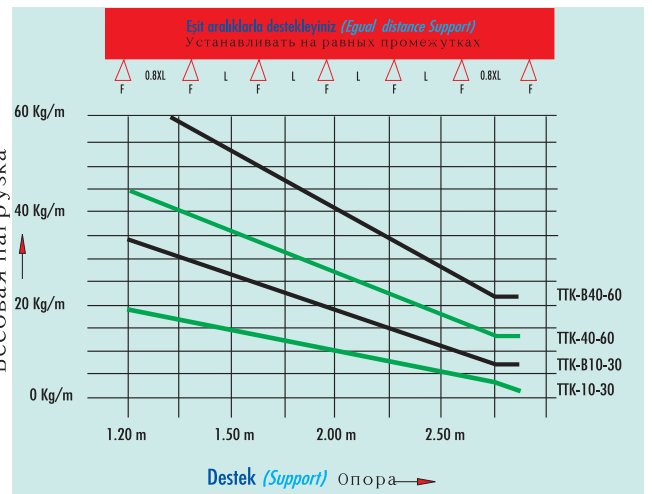

Malzeme : 304-316 (SS 304-316) Kalite Paslanmaz Tel - Sac (Cr Ni).  
Material : 304-316 Quality (SS 304-316) Stainless Steel (Cr-Ni).

TEL KABLO KANALLARI

Wire-mesh Cable Trays

Проволочный лоток

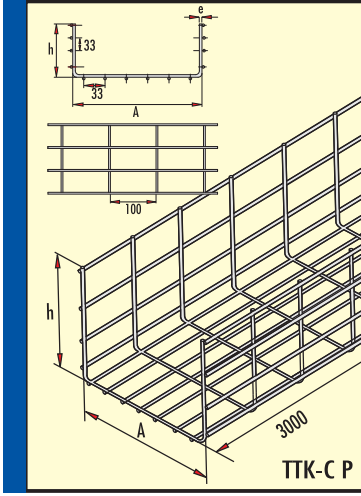

Tel Kablo Kanalı h=120 mm PASLANMAZ TEL (Cr-Ni)  
Wire-mesh Cable Tray h=120 mm Stainless Steel (Cr-Ni)

Проволочный лоток

Sipariş kodu Order code Код заявки	Ağırlık (Kg/mt.) Weight (Kg/mt) Вес (кг/м)	A mm	h mm	e mm	Price list прайс-лист м/у.е.
TTK-C20 P	1.800	200	120	4	54,00
TTK-C30 P	2.200	300	120	4	66,00
TTK-C40 P	2.600	400	120	4	78,00
TTK-C50 P	3.000	500	120	4	90,00
TTK-C60 P	3.400	600	120	4	102,00

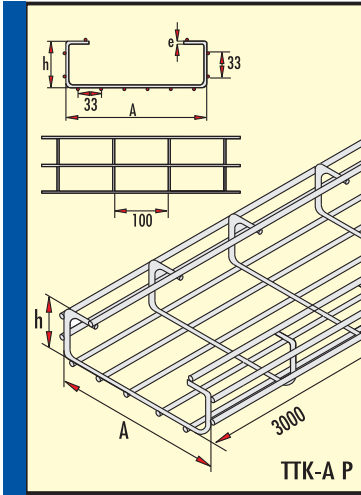
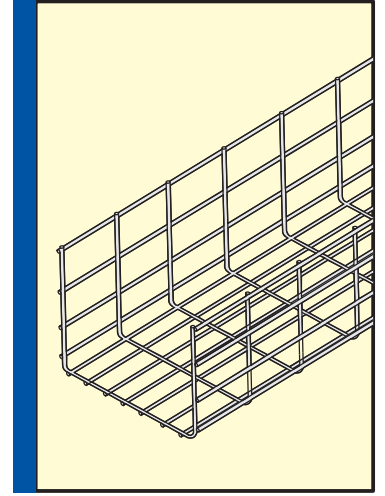

Tel Kablo Kanalı h=60 mm PASLANMAZ TEL (Cr-Ni)  
Wire-mesh Cable Tray h=60 mm Stainless Steel (Cr-Ni)

Проволочный лоток

Sipariş kodu Order code Код заявки	Ağırlık (Kg/mt.) Weight (Kg/mt) Вес (кг/м)	A mm	h mm	e mm	Price list прайс-лист м/у.е.
TTK-A10 P	1.200	100	60	4	36,00
TTK-A20 P	1.600	200	60	4	48,00
TTK-A30 P	2.000	300	60	4	60,00
TTK-A40 P	2.400	400	60	4	72,00
TTK-A50 P	2.800	500	60	4	84,00
TTK-A60 P	3.200	600	60	4	96,00

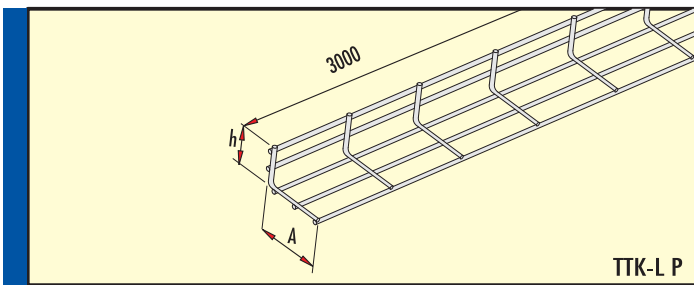
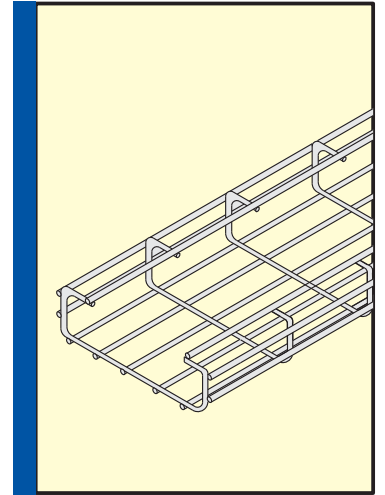

Tel Kablo Kanalı h=60 mm PASLANMAZ TEL (Cr-Ni)  
Wire-mesh Cable Tray h=60 mm Stainless Steel (Cr-Ni)

Проволочный лоток

Sipariş kodu Order code Код заявки	Ağırlık (Kg/mt.) Weight (Kg/mt) Вес (кг/м)	A mm	h mm	e mm	Price list прайс-лист м/у.е.
TTK-L P	0.650	85	50	4	19,50

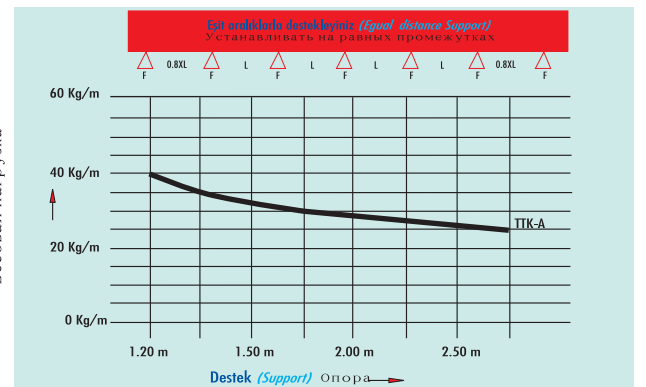
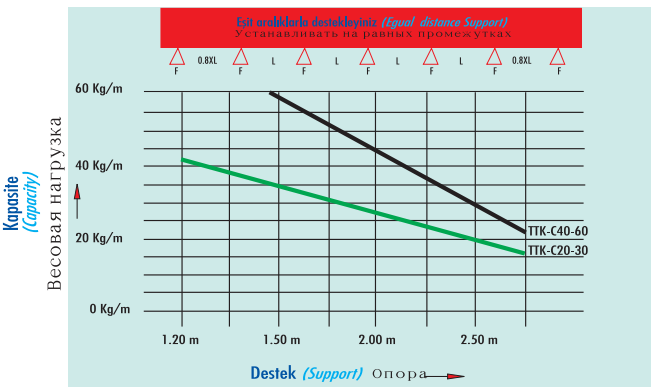

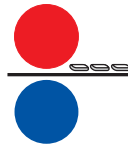

90° DÖNÜŞ ÖRNEKLERİ *Examples of 90° bends* Образцы прямоугольных выпусков

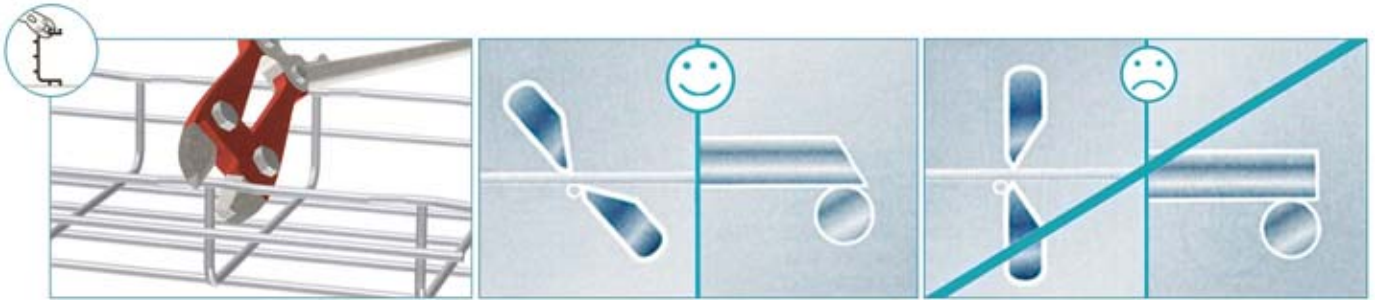

100 mm

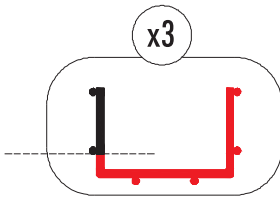
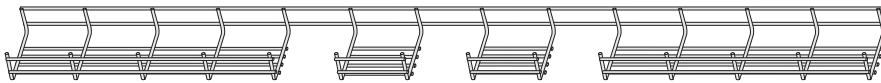

200 mm

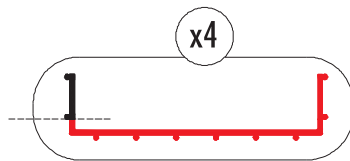
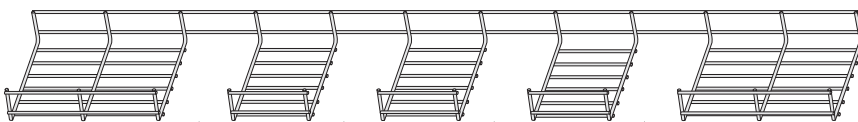

300 mm

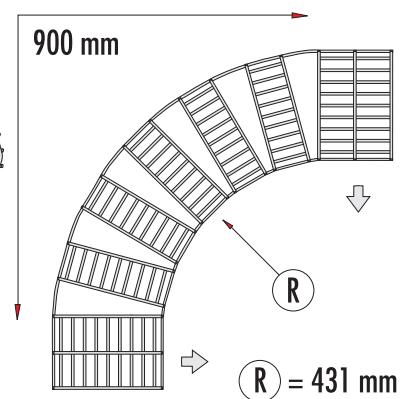
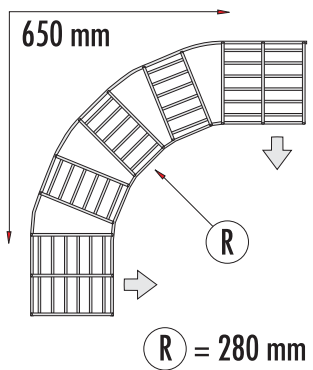
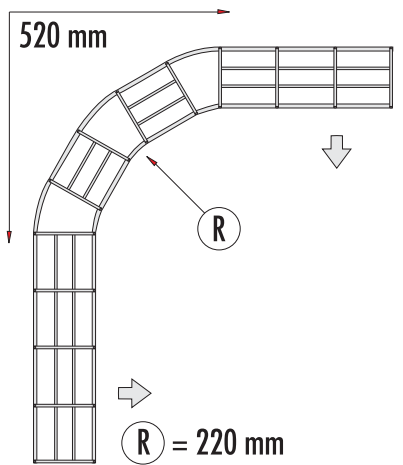
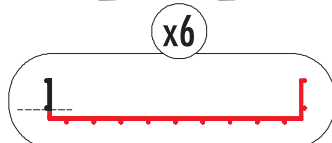
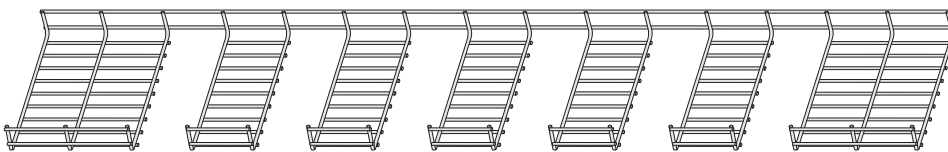



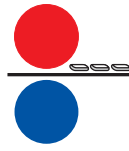

90° DÖNÜŞ ÖRNEKLERİ *Examples of 90° bends* Образцы прямоугольных выпусков

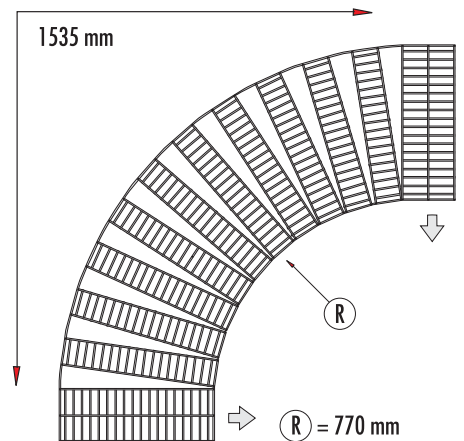
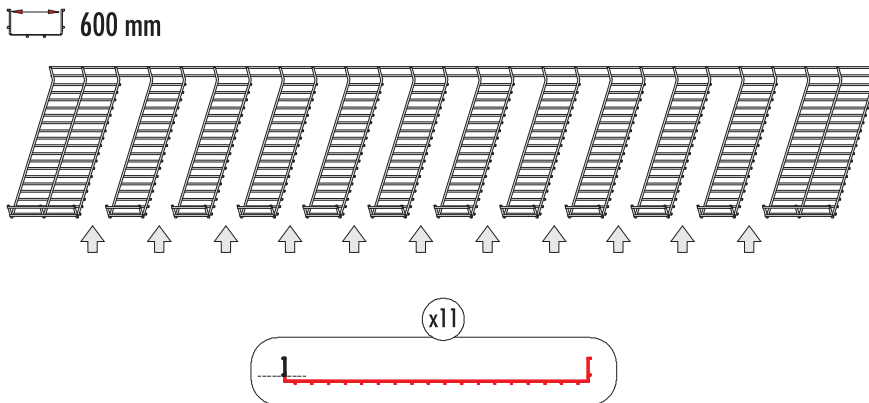
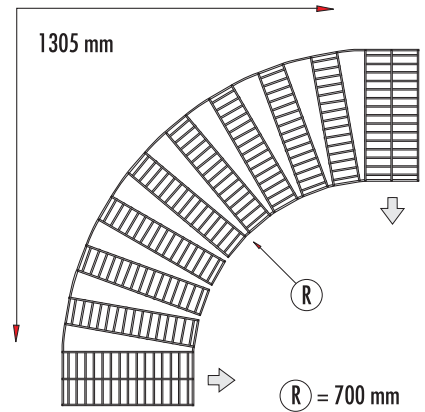
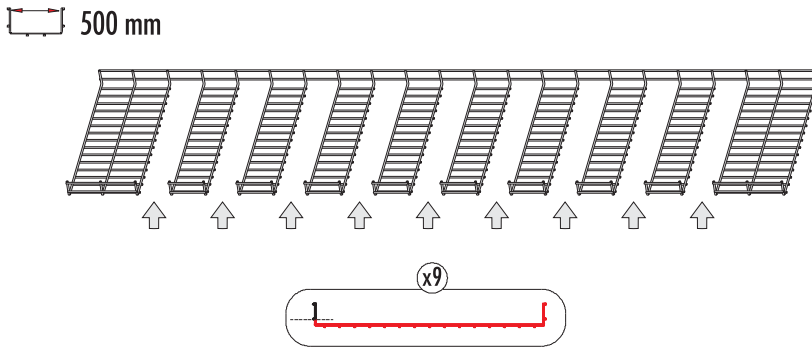
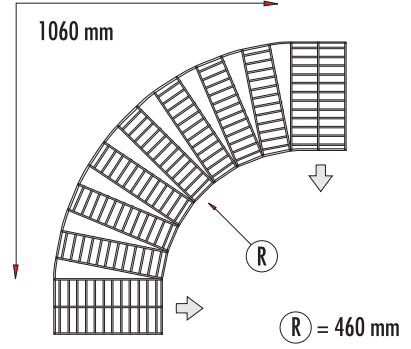
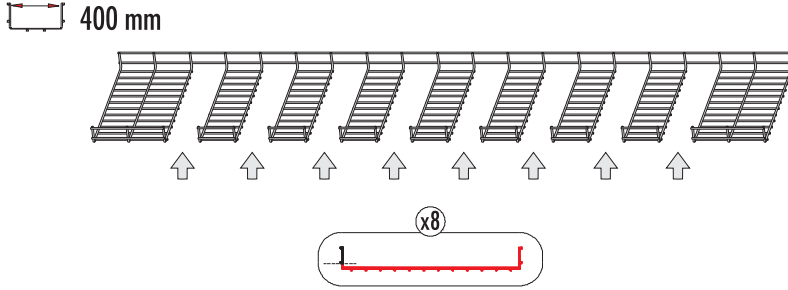

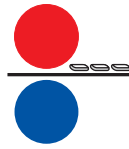

90° DÖNÜŞ ÖRNEKLERİ *Examples of 90° bends* Образцы прямоугольных выпусков

100 mm

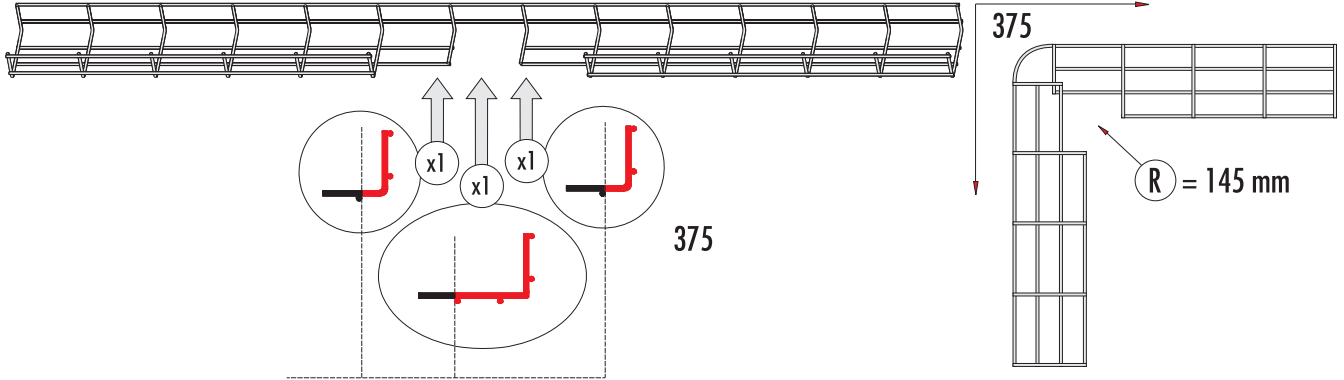

200 mm

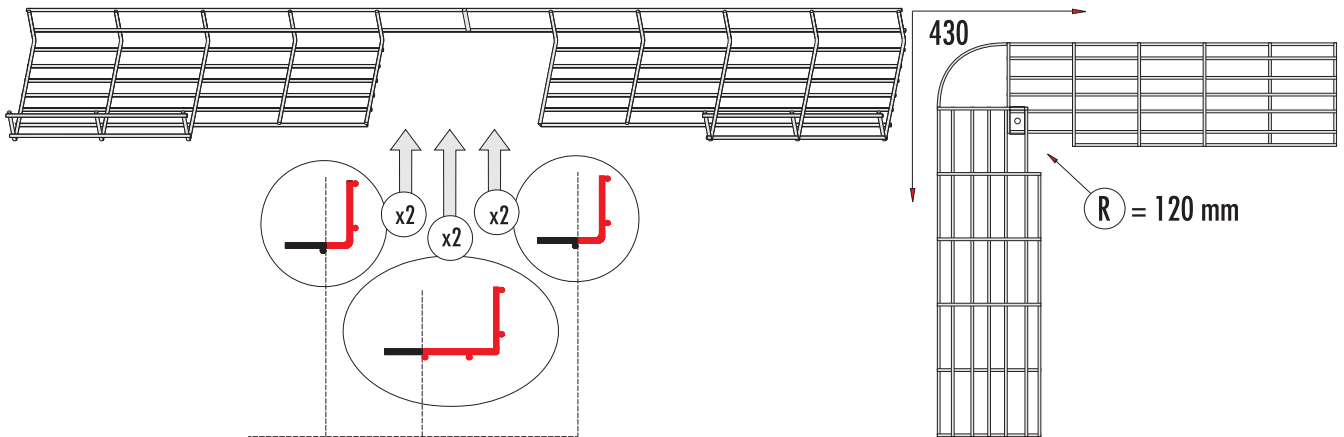

300 mm

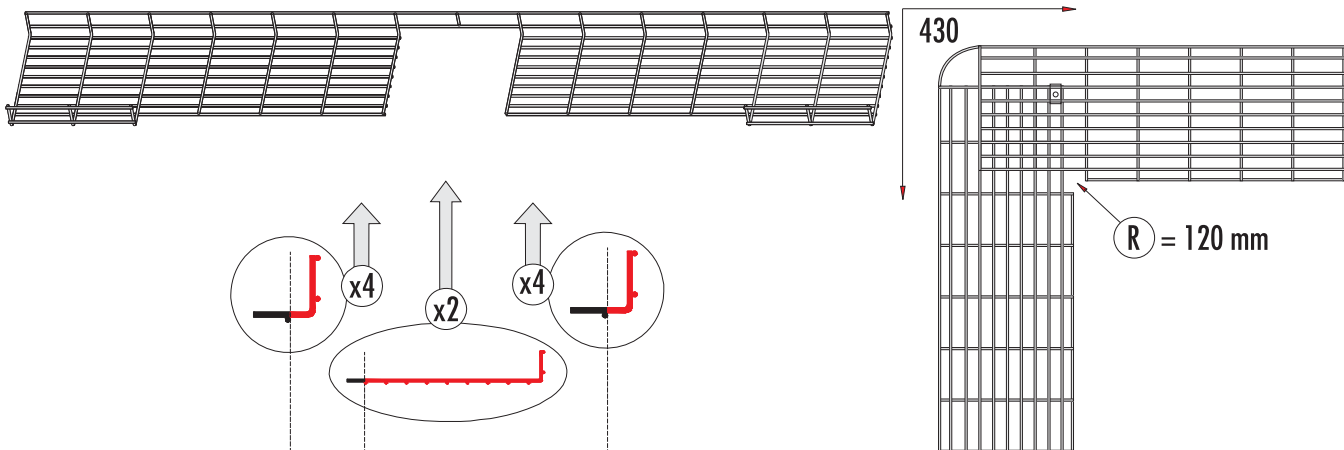

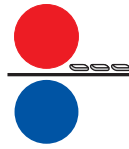

90° DÖNÜŞ ÖRNEKLERİ *Examples of 90° bends* Образцы прямоугольных выпусков

400 mm

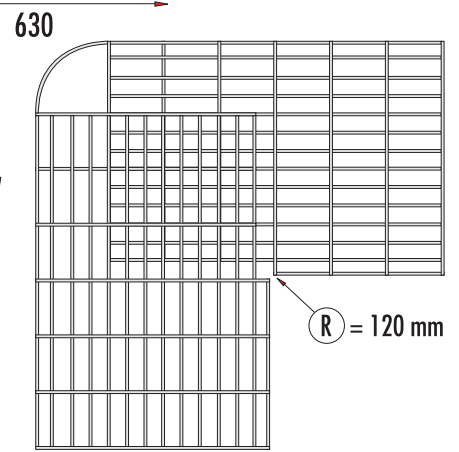
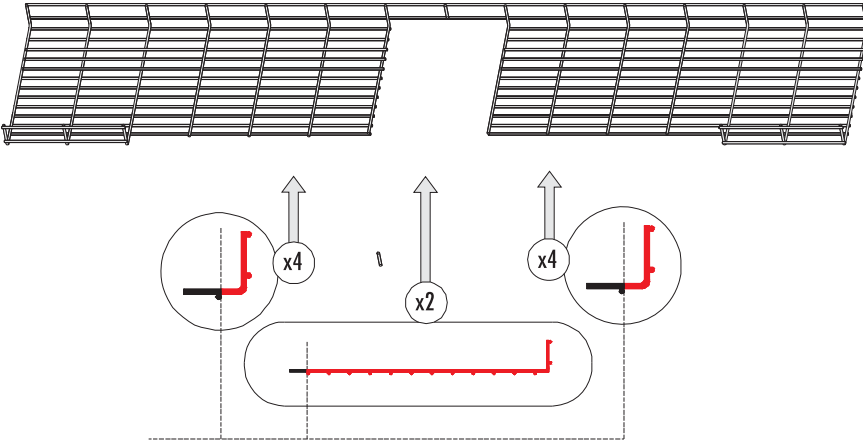

500 mm

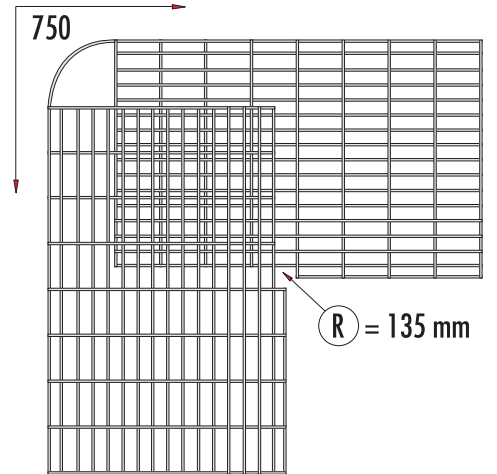
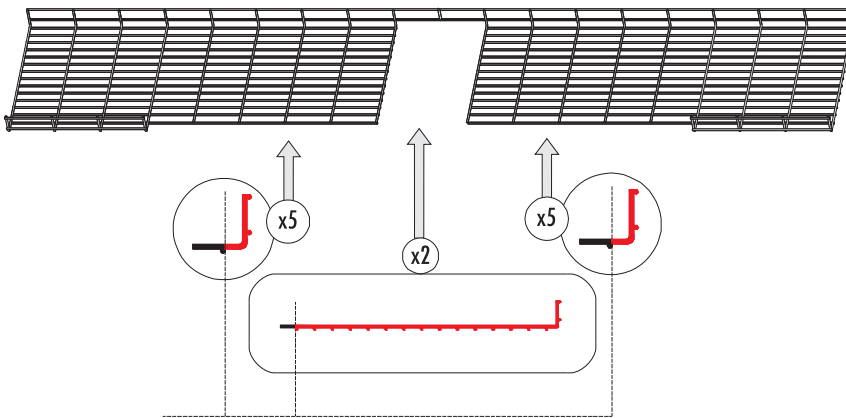

600 mm

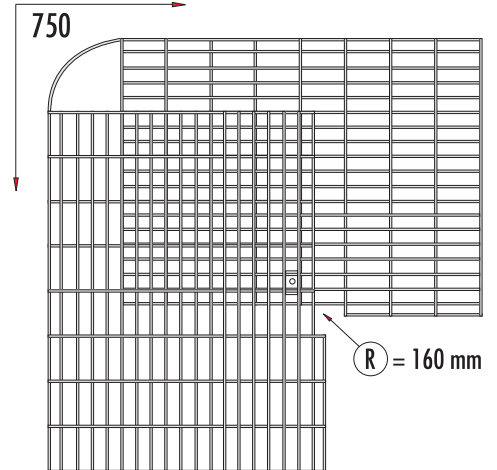
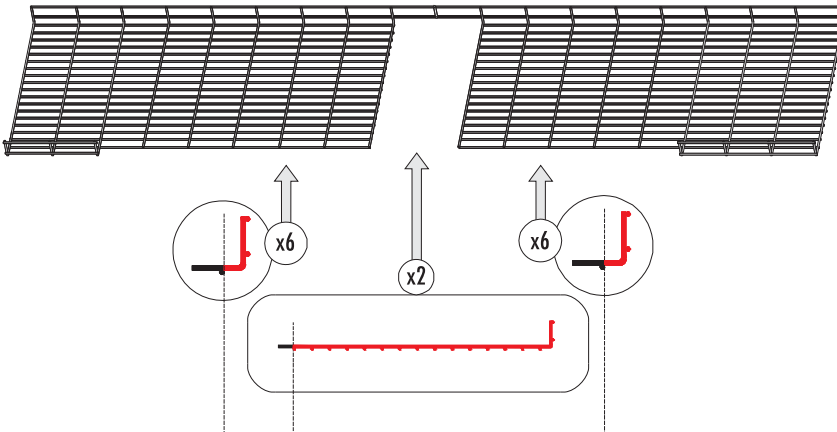

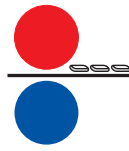

90° DÖNÜŞ ÖRNEKLERİ *Examples of 90° bends* Образцы прямоугольных выпусков

 100 mm

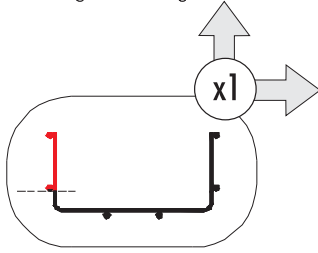
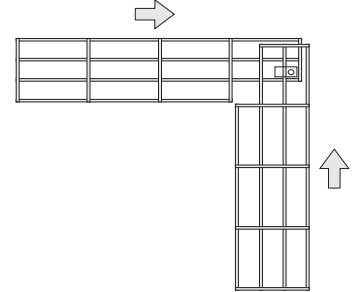
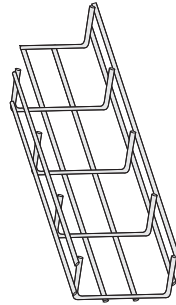
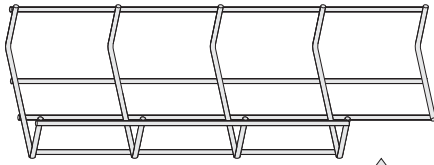

 200 mm

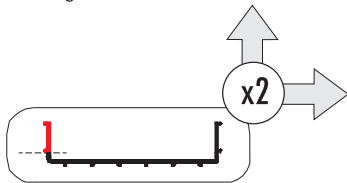
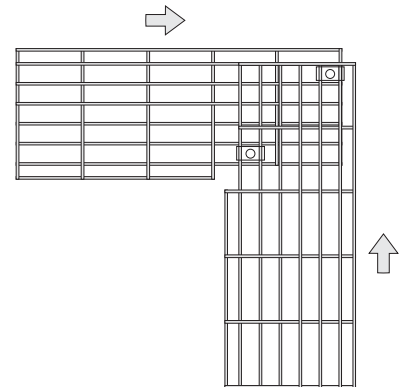
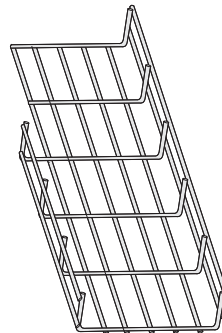
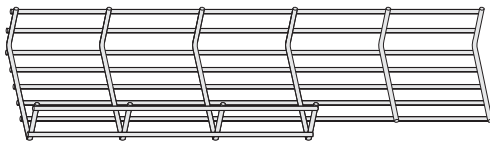

 300 mm

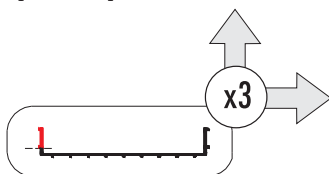
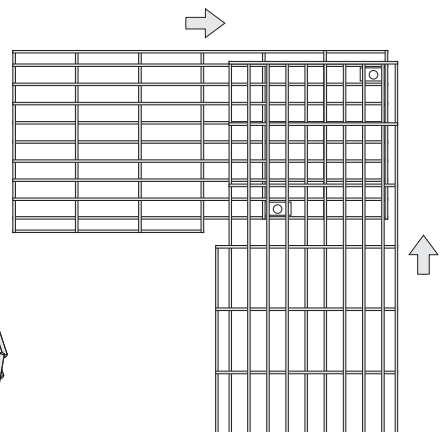
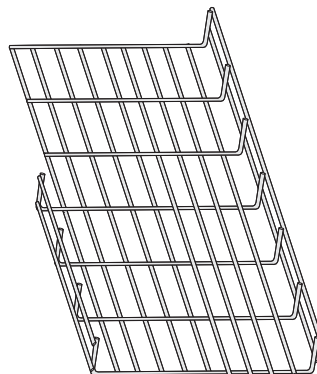
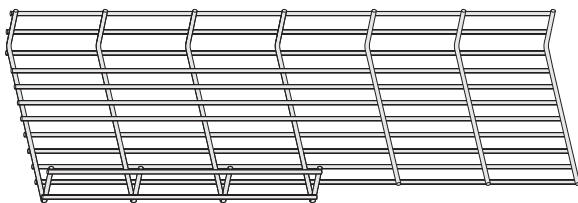



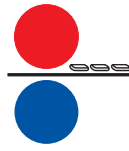

90° DÖNÜŞ ÖRNEKLERİ *Examples of 90° bends* Образцы прямоугольных выпусков

 400 mm

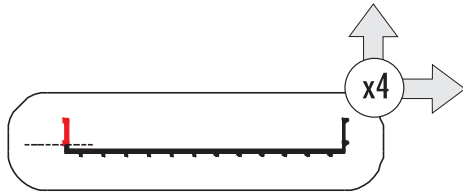
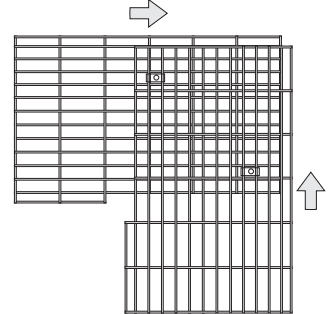
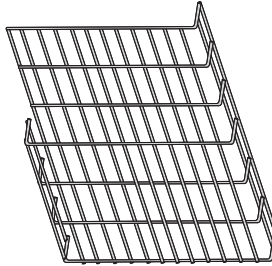
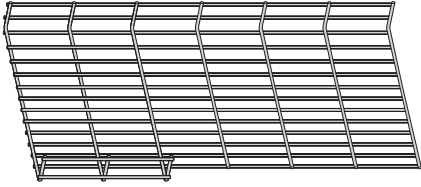

 500 mm

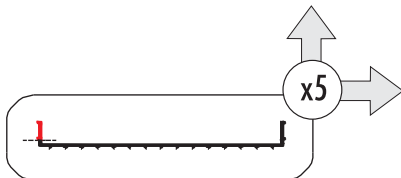
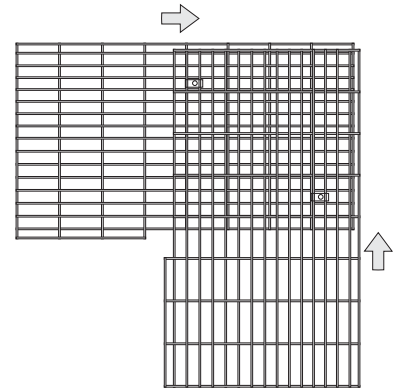
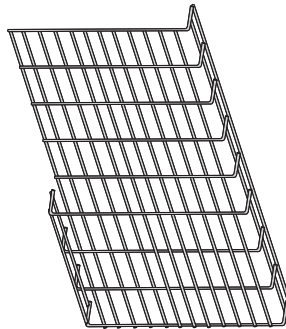
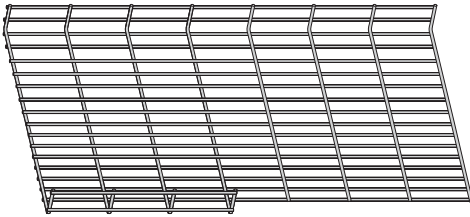

 600 mm

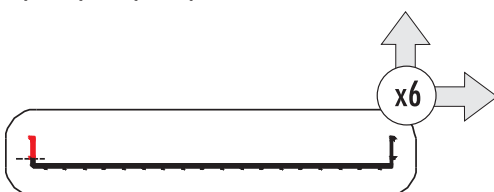
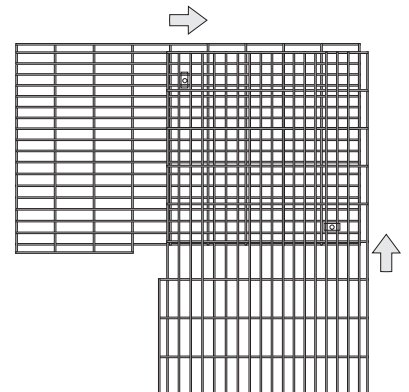
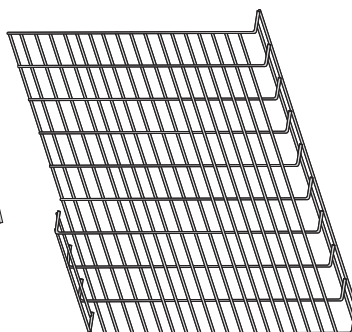
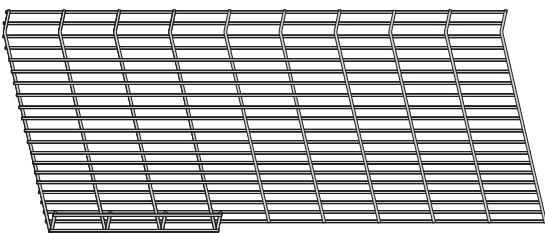

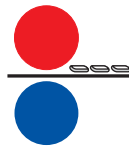

T BAĞLANTI ÖRNEKLERİ *Examples of Tees*

Образцы прямоугольных выпусков

 100 mm

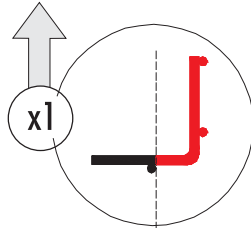
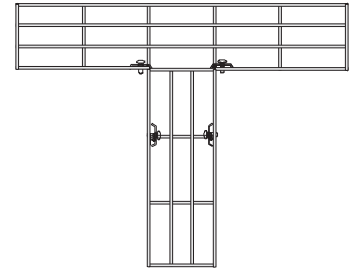
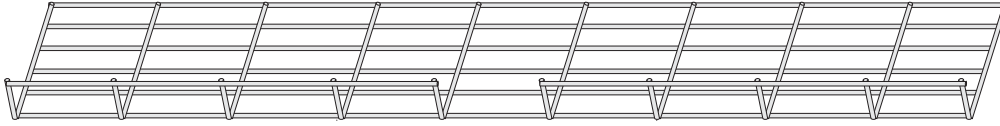

 200 mm

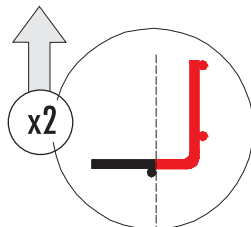
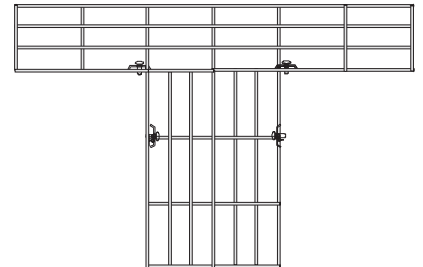
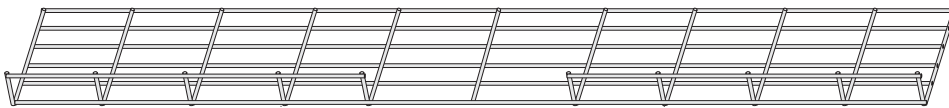

 300 mm

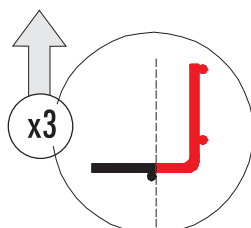
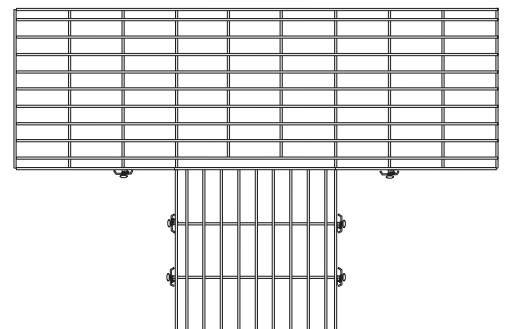

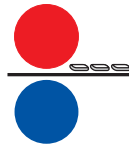

T BAĞLANTI ÖRNEKLERİ *Examples of Tees* Образцы тройников

 400 mm

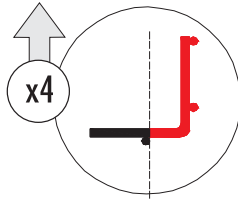
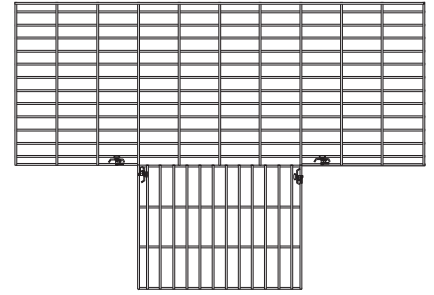
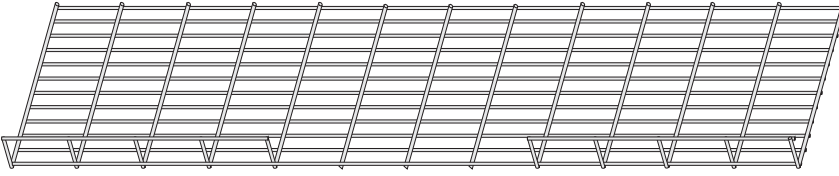

 500 mm

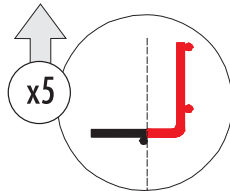
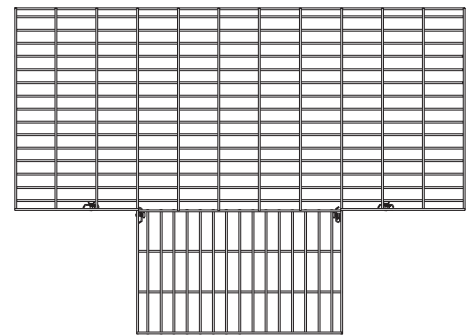
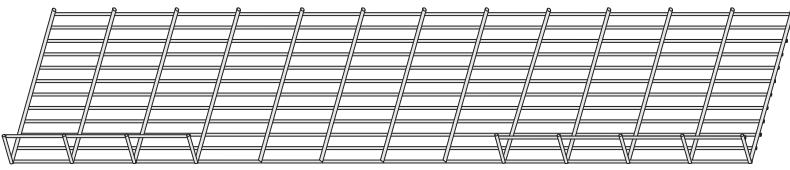

 600 mm

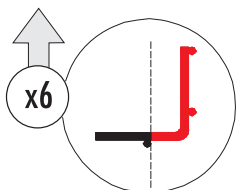
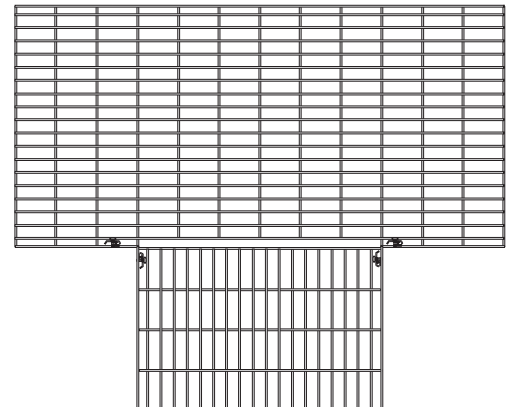
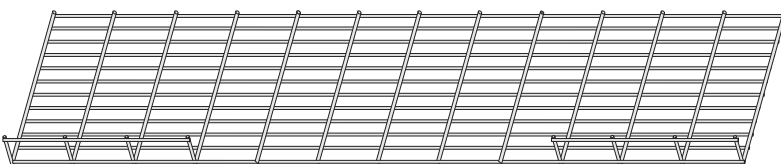

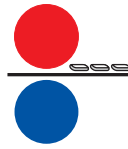

T BAĞLANTI ÖRNEKLERİ *Examples of Tees* Образцы тройников

 100 mm

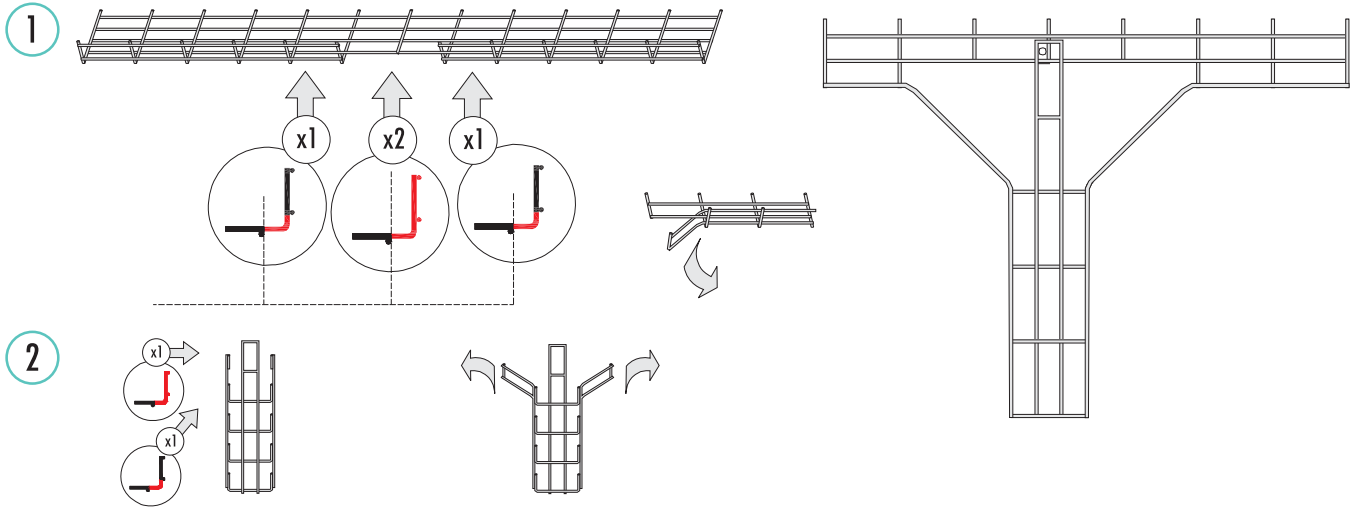

 200 mm

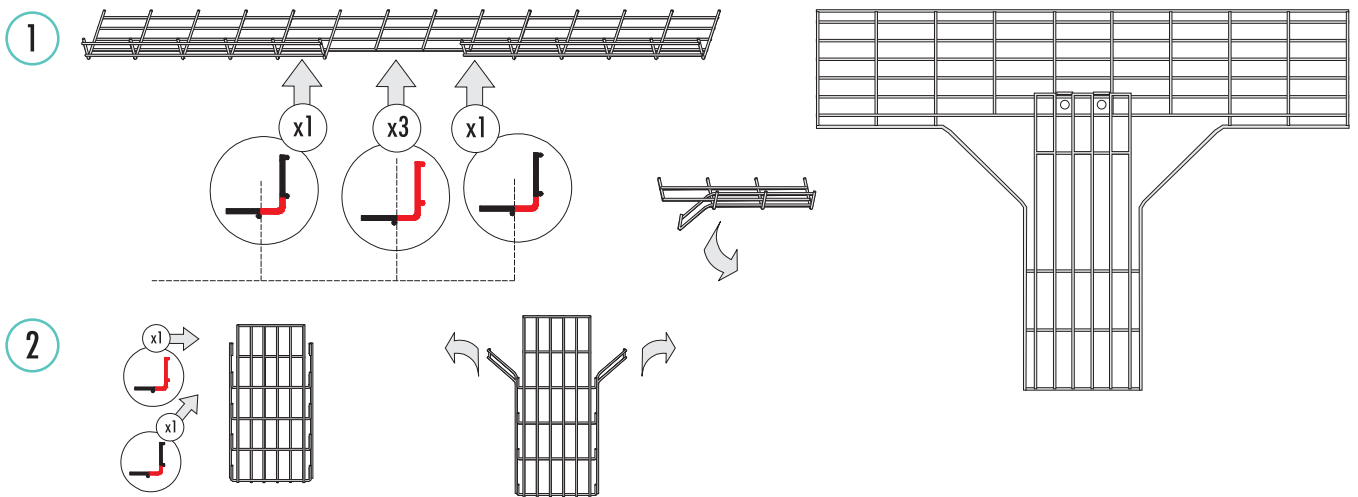

 300 - 500 - 600 mm

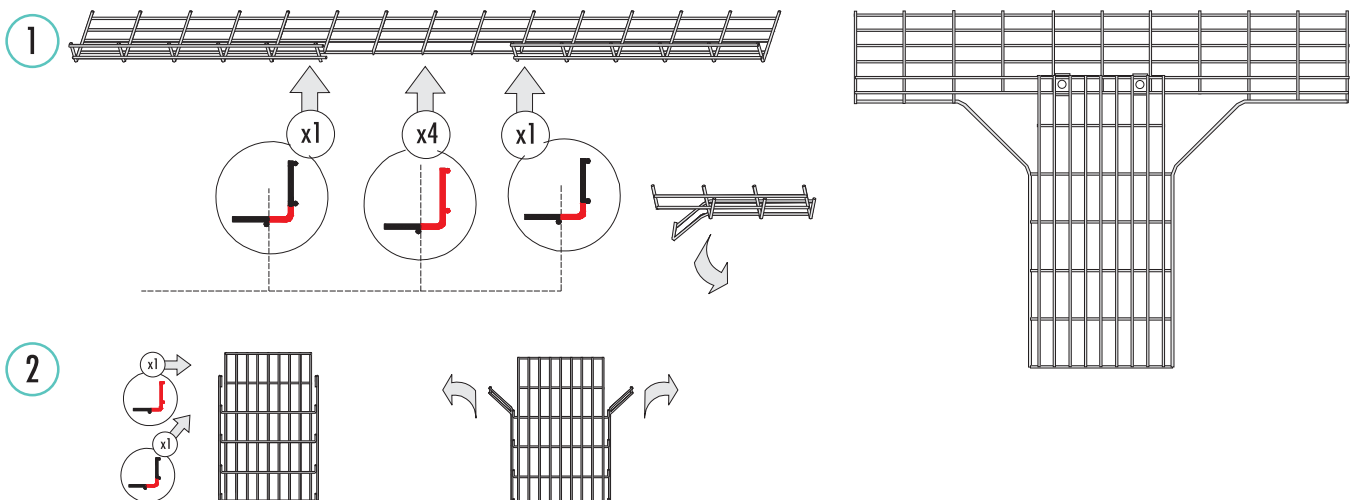



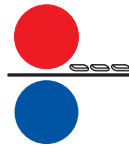

**T BAĞLANTI ÖRNEKLERİ** *Examples of Tees* Образцы тройников

400 mm

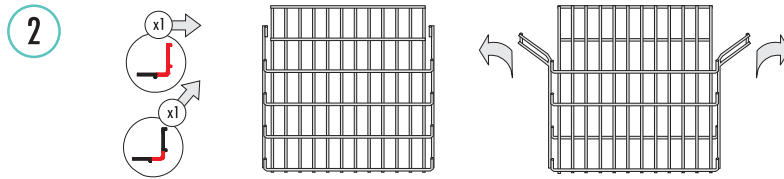
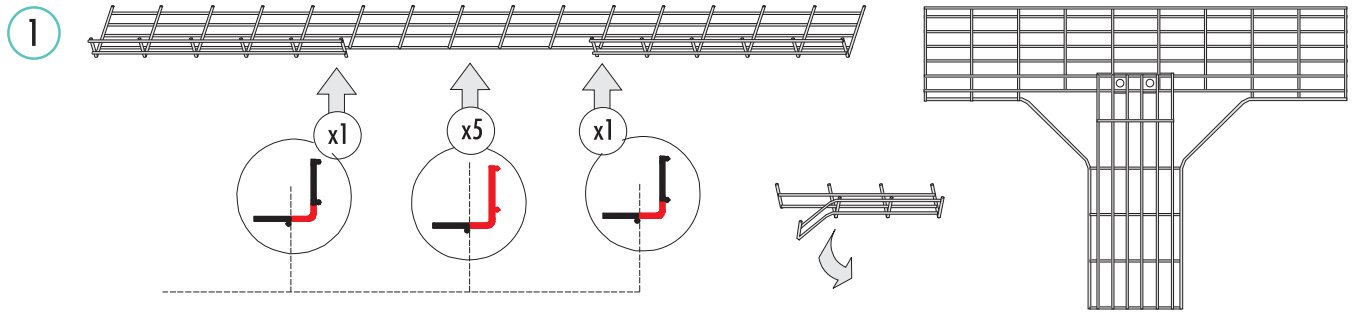

**REDÜKSİYON ÖRNEKLERİ** *Examples of Reducer* Образцы переходных компонентов

100 mm

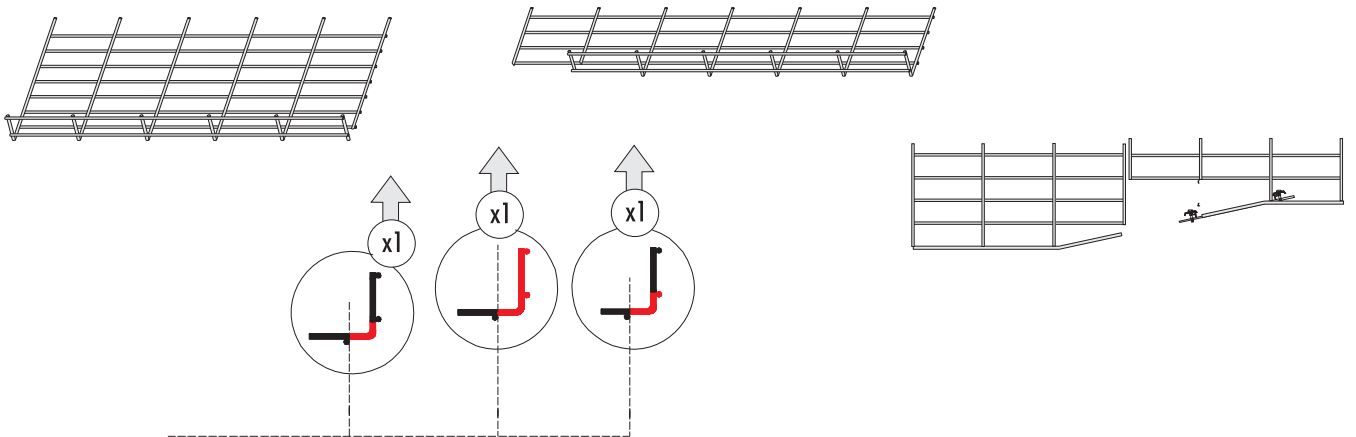

200 mm

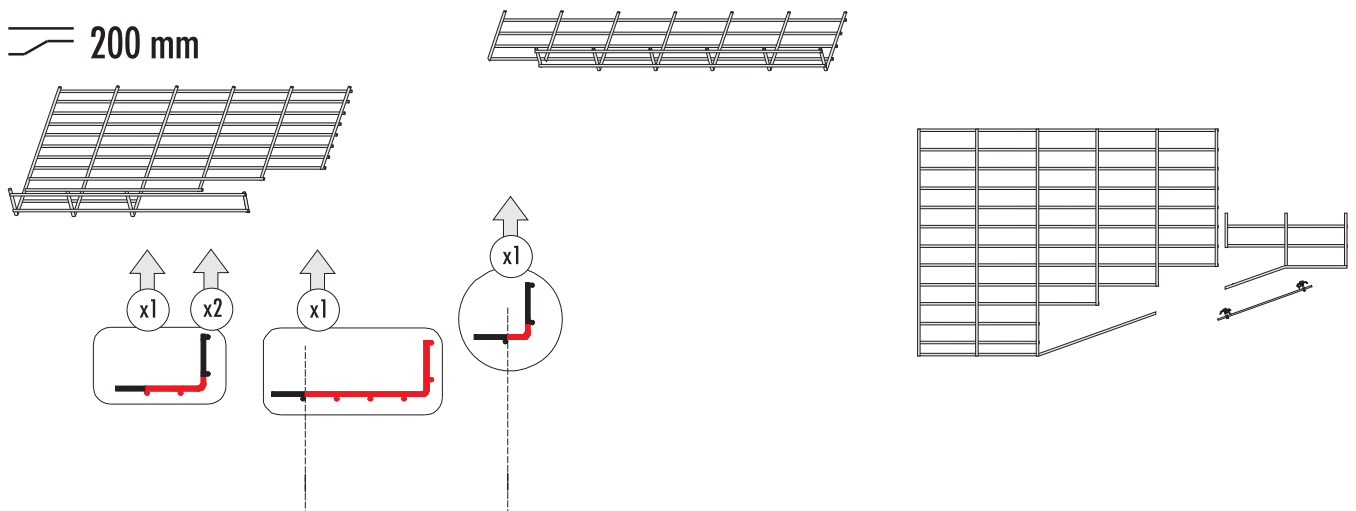

# ŞİRKET PROFİLİ

since  
1980



Elektrik sektörünün öncü kuruluşlarından olan GERSAN A.Ş., enerji santrallerinden evdeki prize kadar uzanan hat üzerindeki iletkenleri taşıyan, birleştiren, koruyan sistemleri ve malzemeleri üretmektedir.

Bu sektördeki üretimlerine 1980 yılında Gersan Ticaret olarak başlamıştır. 1985 yılından itibaren GERSAN A.Ş. olarak devam ederek 33 yıllık bir deneyime sahip olmuştur.

Ana faaliyet alanlarımız;

Binalar,  
Sanayi Tesisleri,  
Fabrikalar,  
Havaalanları,  
Petrol-Gaz Rafinerileri,  
Alışveriş Merkezleri,  
Oteller

gibi üretim-tüketim sistemlerinin ihtiyacı olan

Busbar İletim ve Dağıtım Sistemleri,  
Kablo Taşıyıcı Sistemleri,  
Taşıma-Askı Elemanları,  
Topraklama ve Yıldırımından Korunma Sistemleri,  
Ana-Ara Dağıtım Panoları ve Rack Kabinleri,  
Elektrikli Araç Şarj Sistemleri,  
Otomasyon Sistemleri,  
Döşeme Altı Kanal taşıyıcıları ve Buatları,  
Çeşitli Kablo Birleştirme ve Ayırma Elemanları,  
Kablo ve Boru Etiketleme Sistemleri,  
Özel taşıyıcı, Çelik Konstrüksiyon Birleştirme ve Sabitleştirme Sistemleri,  
Platform Izgaraları Sistemleridir.

GERSAN A.Ş. üretime başladığı günden bu yana işinde uzman teknik ve akademik personeliyle ürünlerin üretimlerinden kullanımına kadar olan aşamasında her türlü teknik hizmet ve çözümleri müşterisine sunmaktadır. Bu anlamda GERSAN A.Ş. tam anlamıyla bir "AR-GE" dolayısıyla "Teknoloji" firması olup müşterilerine geleceğin ürünlerini sunar.

Firmamız bünyesinde bulunan modern test laboratuvarında, IEC/TS EN 61439/1 ve 2 standartlarında adı geçen; Sıcaklık artışının, Elektriksel karakteristiklerinin, Yapısal dayanımın, Ezilmeye karşı dayanımın, Olağandışı ısılara karşı izolasyon dayanımının, Alev yayılımına karşı dayanıklılığın doğrulanması, Yangın bariyeri ve EMC testleri hassas cihazlar ile yapılmaktadır.

Uluslararası belgelere dayandırdığımız üretimlerimiz, GOST, IEC, BS, TSE, EN, ISO 9001 ISO 14001, ISO 18001, CE sertifikalarımız ile Vietnam'dan Şili'ye, Arjantin'den Sri Lanka'ya, Cezayir'den Rusya'ya, Fas'tan Türki Cumhuriyetlere, Arnavutluk'tan Dubai'ye ve Katar'a, çeşitli ülkelerde gerçekleşen projelerde ülkemizin gurur kaynağı olmaktadır.

Kalite politikamız, müşterilerimizin isteklerini karşılayacak kaliteli ürün ve hizmetleri en ekonomik şekilde sunmak, zamanında teslim etmek, hizmetin ve kalitenin sürekliliğini sağlamaktır. Hedefimiz kaliteli ve iyi malzemeyi sürekli olarak üretmektir. Temel hedefimiz, konumuzda bir dünya markası olmaktır.

Ürünlerimiz patentlidir. Gersan A.Ş., %66'i halka açık olan, BIST 100'e kote olmuş bir şirkettir.

## Company Profile

GERSAN A.Ş., a leading company in electrical industry manufactures that carry, combine and protect systems and materials conductive over the line from power plants to the sockets at houses.

Manufacture in this industry started in 1980 under the name Gersan Ticaret. From 1985 onwards, it went on business under the name GERSAN A.Ş. and had an experience spanning 33 years.

Our main fields of operations are: manufacture of Busbar transmission and Distribution systems, Cable support systems, Grounding and Lightning prevention systems, spark gap arresters, main and intermediate distribution plates, elevated type cable supports and bays, ventilation systems, support elements, various cable combinations, disconnect, connect and support elements, cable and pipe tagging systems, special conveyors that must be applied at any kind of projects, steel construction combination and fixation systems required for Building, Industrial plants, Car factories, Airports, Oil-Gas refineries, Malls, platform grills and fixation to concrete systems.

Since the very first day of starting production, GERSAN A.Ş., provides any kind of technical services and solutions to its customers at stages from production of items to their use with qualified technical and academic personnel. In this sense, GERSAN A.Ş. is a complete "R&D" and "Technology" company and provides its customers with the future's products.

Verification of temperature increase, electrical characteristics, structural strength, strength against crush, isolation strength against extraordinary temperatures, flame propagation strength, fire barrier, voltage decrease in system and EMC tests mentioned in IEC EN 61439/1 and 2 standards are executed by means of precision devices. Our items which hold international certificates such as GOST, IEC, BS, TSE, EN, ISO 9001, ISO 14001, ISO 18001 CE are source of pride at projects realized at various countries such as Viet Nam, Chili, Argentina, Sri Lanka, Algeria, Russia Morocco, Turkic countries, Albania, Dubai and Qatar. Our quality policy is to offer quality items and services that would meet requirements of our customers for competitive prices, to make timely deliveries and to ensure continuance of high quality items. Our target is constantly producing service and quality. Our basic target is to be a world brand at our field of operation.

Our products are under patent. Gersan A.Ş. is a 66% publicly held company quoted to BIST 100 (Istanbul Stock Exchange)

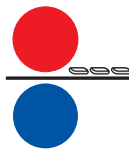

## DÜNYADA TEDARİKÇİSİ OLDUĞUMUZ FİRMALAR *The Companies Which We Supply Materials in Worldwide*

Компании, с которыми мы сотрудничаем по всему миру

### ALSTOM

Alstom Power Systems  
4,avenue Andre Malraux  
92309 Levallois Perret Cedex - FRANCE  
Tel:+33(0) 141492000 Fax:+33(0) 141492485

### SIEMENS

Siemens Pakistan Engineering Co. LTD.  
B-72 ESTATE AVENUE S.I.T.E  
P.O BOX 7158 KARACHI-75700 PAKISTAN



AREVA T&D - ERT 3135  
1, Rue Paul Doumer, BP601 - 73106 Aix-les-Bains  
Cedex - FRANCE  
Tel:+33 (0)4 79 88 79 80 Fax:+33 (0)4 79 88 79 39



Petrofac International LTD.  
Petrofac House, Al-Soor street  
P.O. Box:23467 SHARJAH/U.A.E.



Mitsubishi Electric Corporation  
P O Box 1554, Dubai, UAE.Tel: + (971) 4 282 7763  
Fax: + (971) 4 282 7716



Sun International Corporation (SIC) FZC  
P.O. Box -7964, Saif Zone, Sharjah, UAE.  
Tel: - 06-55 72 197 Fax: -06 - 55 72 460



ABB INDUSTRIES LLC .  
P.O.BOX 11070.....DUBAI, U.A.E.  
TEL: +971 4 3401777 FAX: +971 4 3401530

### SIDEM

SIDEM (STÉ INTERNATIONALE DE DESSALEMENT)  
20-22 rue de Clichy 75009 PARIS - FRANCE  
Phone :+33 149 957 676 Fax :+33 149 957 695

132/11KV SUBSTATION & ASSOCIATED 132KV CABLE WORKS AT OLD TOWN & BURJ RESIDENCE 132/11KV SUBSTATION

QTSE - PHASE 9 PROJECT (SUBSTATION) KAHRAMAA QATAR- KDPC - AGIP KCO G.M.R.A PROJECT (LIBYA)

BAKU-TBILISI-CEYHAN CRUDE OIL PIPELINE PROJECT (NORTH)

CNE/015/2002 JEBEL ALI POWER & DESALINATION STATION - L STATION, PHASE 1, DUBAI

DUBAI METRO PHASE I - RED LINE N9-05681

STATION CONTEXT PLANNING N9-5972

VIDEO BROADCASTING SYSTEM IN STATION N9-5974

RASHIDIYA CAR PARK N9-5976

JUMEIRAH ISLAND CAR PARK N9-5978

MARAFIQU WATER PLANT K.S.A.

DUBAI METRO GREEN LINE AL GHUSAIS CAR PARK

AGIP/KCO 2002/0973 - EXPANSION EPC NORTH OFFSITES

KASHAGAN OIL FIELD DEVELOPMENT

JEBEL ALI AIRPORT CITY PHASE-1A AIRFIELD AND INFRASTRUCTURE CONTRACT NO: JXB1/INF/041

CENTRAL UTILITY COMPLEXES - CUC2

KASHAGAN OIL FIELD DEVELOPMENT

ADCOP - ABU DHABI CRUDE OIL & PIPELINE PROJECT HABSHAN TO FUJAIRAH

MAHBAS AL-CIN MAKKAH / K.S.A (BUS-BAR)

BAKMEY TOWER / K.S.A (BUS-BAR)

SHERATON HOTEL - MAKKAH / K.S.A (BUS-BAR)

BOGARY TOWER - MAKKAH / K.S.A (BUS-BAR)

JUFFALI MERCEDES / K.S.A (BUS-BAR)

NURSE ACCOMMODATION BUILDING - TAIF / K.S.A (BUS-BAR)

MECHNIKOVA SIDING FACTORY / UKRAINE (BUS-BAR)

OCTAPharma / GERMANY (BUS-BAR)

ENERCON / GERMANY (BUS-BAR)

AKIJ FOOD / BANGLADESH (BUS-BAR)

AKIJ CERAMICS / BANGLADESH (BUS-BAR)

AKIJ TEXTILE / BANGLADESH (BUS-BAR)

DHAKA TOBACCO / BANGLADESH (BUS-BAR)

TRZ GARMENTS INDUSTRY / BANGLADESH (BUS-BAR)

ALEMA TEXTILE / BANGLADESH (BUS-BAR)

MANAMI FASHION / BANGLADESH (BUS-BAR)

SATURN TEXTILE / BANGLADESH (BUS-BAR)

BEL CONSTRUCTION / BANGLADESH (BUS-BAR)

MUGLAD BASIN FIELD SURFACE FACILITIES - PHASE 4

HASDARBUL PROJECT: ONSHORE TERMINAL, TUNISIA

KARAN UTILITIES & CO-GENERATION PROJECT

EL MERK CENTRAL PROCESSING FACILITY

DOHA NORTH PUMPING & SEWAGE TREATMENT PLANT-QATAR

CPF PHASE 1, BADRA OIL FIELD PROJECT IRAQ

CARTAGENA LUBE BASE OIL COMPLEX-PHASE 2 IN CARTAGENA-SPAIN

KAUTHER DEPLETION COMPRESSION PROJECT

QP STORAGE TANKS PRG - GALFAR

EPIC FOR FUEL GAS SUPPLY TO QNCC-IV & GCC-I PLANTS AT UM-BAB

AMAL POWER STATION

ABU DHABI CRUDE OIL PIPELINE PROJECT HABSHAN- FUJAIRAH

KINGDOM OF SHEBA - UAE

LAJANURI HYDRO POWER PLANT, GEORGIA

NEHUENCO STEAM POWER PLANT, CHILE

PHU MY COMBINED CYCLE POWER PLANT, VIETNAM

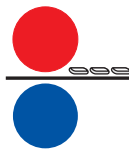

## DÜNYADA TEDARİKÇİSİ OLDUĞUMUZ FİRMALAR *The Companies Which We Supply Materials in Worldwide*

Компании, с которыми мы сотрудничаем по всему миру



### 3M Colombia S.A

Avenida El Dorado N° 75-93  
Tel: 57 1 4161666 www.3m.com.co



P.O Box 30569 Abu Dhabi - U.A.E  
Tel:02-6765654,02-6746764 Fax:02-6745654  
Mobile:050-6668750



### Thales International Middle East (Branches)

P.O. Box: 125118 - DUBAI (UAE)  
Tel:+ 971 (0) 4 299 44 12  
Fax: +971 (0) 4 299 41 01



42-A Suite-15 Dostyk Ave 050010  
Almaty City - REPUBLIC OF KAZAKHISTAN  
TEL : 007-7272-304663 FAX : 007-7272-304235



Denge Energy LTD.  
Atambaeva Str. No:10B Atyrau City.  
REPUBLIC OF KAZAKHISTAN  
Tel: 007 7122 45 72 97 Fax: 007 7122 49 13 47



Luster Star CHANDELIER INT. CENTER (AL HADDAD CENTER) BALADIYE STR. 2nd FLOOR NO:317, JEDDAH, SAUDI ARABIA



E-Sys Nederland B.V.  
Energieweg 5 3281 NH  
Numansdorp / The Netherlands  
P +31 (0) 186 - 655238 M  
+31 (0) 6 - 53530299 aydin@e-sys.nl

PETRONAS - IRAQ WC2  
 ENOC FUJAIRAH DISTRIBUTION & TRADING TERMINAL - UAE  
 DOHA SOUTH SEWAGE TREATMENT WORKS - QATAR  
 RUWAI'S REFINERY EXPANSION PROJECT - ABUDHABI  
 BOROUGE III PROJECT - ABUDHABI  
 TRAFFIC CONTROL TOWER- JEBEL ALI AIRPORT  
 R-885 : COMPREHENSIVE IMPROVEMENT TO ITTIHAD ROAD (PHASE II)  
 EMAL CG5460: MAINTENANCE SHOP, CATHODE SEALING, POT LINING FACILITIES  
 DUBAI AIRPORT ROADS IMPROVEMENTS PHASE II  
 EMAL CAST HOUSE EMAL - EMIRATES ALUMINUM  
 LARGE CAPACITY DC SYSTEM ETISALAT  
 AL SOWWAH ISLAND ROADS, BRIDGES INFRASTRUCTURE WORKS PACKAGE PHASE-1 A,B & C  
 DEWA CONTRACTOR CE/002D/2005 SUPPLY, INSTALLATION, TESTING AND COMMISSIONING OF 132/11KV SUBSTATION & ASSOCIATED WORKS  
 SUPPLY, INSTALLATION, TESTING AND COMMISSIONING OF 132/11KV SUBSTATION & ASSOCIATED WORKS AT DUBAI MOTOR CITY  
 DEWA CONTRACT CE/448C/2007- 132/11KV SUBSTATION  
 DUBAI WORLD CENTRAL INTERNATIONAL AIRPORT- AIR TRAFFIC CONTROL TOWER- JEBEL ALI AIRPORT  
 DEWA CONTRACTOR CE/002A/2005 SUPPLY, INSTALLATION, TESTING AND COMMISSIONING OF 132/11KV SUBSTATION & ASSOCIATED WORKS  
 132/22KV SUBSTATIONS AND ASSOCIATED WORKS AT PALM DEIRA  
 132/11KV SUBSTATIONS AND ASSOCIATED WORKS AT BUSINESS PARK (P/186 & MASKHAN PE/096 SUBSTATIONS)  
 132/33KV SUBSTATION & ASSOCIATED WORKS - DEWA CONTRACT NO. CE/448A/2007  
 RAS AL KHOR CROSSING - CONTRACT R800/5 RTA, DUBAI  
 DOUBLE DECKING OF DOHA ROAD RTA, DUBAI  
 MITSUBISHI HEAVY INDUSTRIES LTD  
 DUBAI METRO PHASE I - RED LINE N9-05681  
 STATION CONTEXT PLANNING N9-5972  
 VIDEO BROADCASTING SYSTEM IN STATION N9-5974  
 RASHIDIYA CAR PARK N9-5976  
 JUMEIRAH ISLAND CAR PARK N9-5978  
 KAUTHER DEPLETION COMPRESSION PROJECT  
 HARWEEL PROJECT  
 HASDARBUL PROJECT: ONSHORE TERMINAL, TUNISIA  
 SALAM GAS TREATMENT UNIT TRAIN - 3/4, (SGT 3/4) EGYPT  
 NEW GAS PROCESSING PLANT, SAJAA - SHARJAH  
 REPLACEMENT OF NK CRUDE OIL EXPORT SYSTEM, KUWAIT  
 KOC FACILITY UPGRADE AND RELOCATION OF UNDERGROUND PROCESS PIPING FOR GC'S 3, 4, 6, 7, 8, 21, 23, BS 140 AND BS 150  
 EBLA GAS PROJECT, SYRIA  
 JIHAR STAGE 3 PROJECT SYRIA  
 KASHAGAN PROJECT  
 40" GAS PIPELINE FROM BS 131 TO LPG PLANT AT MAA  
 KARAN UTILITIES & CO-GENERATION PROJECT  
 132/11 KV & 132/33/11 KV SUBSTATION WORKS IN NORTHERN EMIRATES  
 CNE599B - DUBAI LAND 2  
 4X132 KV SUBSTATIONS - KHALIFA PARK,  
 E-1, W2 & KHALIFA II A  
 MAMZAR BEACH SUBSTATION  
 DUBAI WORLD CENTRAL INTERNATIONAL AIRPORT JXB1/INF/043 & JXB/INF045:  
 DEWA 132/11KV SUBSTATION AND  
 132 KV CABLING WORKS



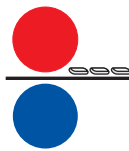

## DÜNYADA TEDARİKÇİSİ OLDUĞUMUZ FİRMALAR *The Companies Which We Supply Materials in Worldwide*

Компании, с которыми мы сотрудничаем по всему миру



**Eurostrut / E-strut B.V.**  
P.O. Box 10025 3004 AA Rotterdam  
Ringersstraat 9 3125 BP Schiedam / The Netherlands  
Tel: +31 (0)10 522 33 51 Fax: +31 (0)10 521 49 51



Moshaw Balfuria  
Tel: +972-4-659 22-44 Fax: +972-4-659-23 04  
Email: sales@sche-netzer.com



115191, Russia, Moskovskaya obl.,  
MOSKVA, 2-ya Roshinskaya. 4.  
Tel : +7(495)2408275  
www.gersan-elektrik.ru rs-bs@ya.ru



**RTI S.p.A.** via Ambrosoli, 2/A 20090  
Rodano Millepini (MI) - Italy  
Tel: +39 02 95328610 Fax: +39 02 95328611

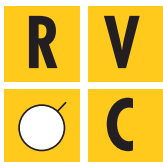

**Raymond Vella & Co. Ltd.**  
Head Office - Stores - Showroom 65, Villa Vellas,  
San Gorg Preca Street, Hamrun, HMR1600. Malta  
Tel (+356) 2122 3527 Fax (+356) 2123 3378  
http://www.rvcltd.com Email: ray@rvcltd.com.mt



**Anord Control Systems Ltd.**  
Coes Road Industrial Estate, Dundalk,  
Co. Louth, IRELAND DDI +353 42 9320581  
Tel +353 42 9320500 Fax +353 42 9338907

CE/024A/04 - 9 SUBSTATION, DUBAI  
NTDC-KESC INTERCONNECTION PROJECT, KARACHI  
CITY OF ARABIA - II/132/11KV SUBSTATION  
DUBAI SPORTS CITY  
BURJ DUBAI DEVELOPMENT PHASE II  
DUBAI WORLD CENTRAL INTERNATIONAL AIRPORT JXB1/INF/042: DEWA 132/11KV SUBSTATION AND  
132KV CABLING WORKS  
REZD/E/2008/1 - TATWEER DUBAILAND 8X132/11KV SUBSTATIONS  
3X132/11KV SUBSTATIONS - DEWA CE/0716  
(AID CITY S/S, AL NAHDA S/S & TERMINAL 2 S/S)  
NAIMIYA SUBSTATION OF AJMAN - FEWA  
NAHEEL OLD TOWN SUBSTATION RAS AL KHAIMAH- FEWA  
MARITZA EAST 1  
STAYTHROPE C CCGT POWER STATION (UK)  
MAROWE DAM PROJECT (SUDAN)  
CYCOFOS PROJECT (FRANCE)  
DUBAL GTX COGENERATION (FRANCE)  
MAROCCO PROJECT 400 KV(MAROCCO)  
ZAWIA EXTENSION (LIBYA)  
ALUAR PROJECT -ARGENTINA  
SYRIA PROJECT  
RELIZANE - 3 X 155 MW  
KESTREL PROJECT II, DUBAI  
ALBA POWER STATION 4, BAHRAIN  
CERNOVADA NUCLEAR POWER PLANT, ROMANIA  
HO PING COAL FIRED  
DERINER HYDRO POWER PLANT (ARTVIN), TURKEY  
DRIMRIVER HYDRO POWER PLANT, ALBIE  
WASHASH GAS INSULATED, ADAMIYA AIR INSULATED, POWER SUBSTATIONS WASHASH, IRAQ  
CAN 2x160 MW CFB THERMAL POWER PLANT CANAKKALE, TR.  
ALSTOM BHT FACTORY STEELWORKS (CEDEX), FRANCE  
LAJANURI HYDRO POWER PLANT, GEORGIA  
NEHUENCO STEAM POWER PLANT, CHILE  
PHU MY COMBINED CYCLE POWER PLANT, VIETNAM  
QATALUM - POWER GENERATION  
GTC/144A/2006 QTSE - PHASE VIII PROJECT (SUBSTATION)  
BARSHA & HORSE RACE - DUBAI  
DEWA CE/220A/2007  
132/22KV SUBSTATIONS AND ASSOCIATED WORKS AT PALM DEIRA  
APF PARAFODURE FACTORY, FRANCE  
ERT MOROCCO PROJECT, CASABLANCA  
DEWA CONTRACT CE716 - 8 SUBSTATIONS (SKLN, KFAF, BIRD, LBAC, KNWJ, MCLB & WSHP)  
BAHRAIN AL DUR PROJECT  
BAHRAIN 66kV CITY TEE SUBSTATIONS 2011  
S350-SEWA- TUNNEL LIGHTNING AT CULTURAL SQUARE, SHARJAH  
HV/LV ELECTRICAL & INSTRUMENTATION WORKS FOR POT LINE 7, DUBAI  
HIGH BAY LIGHTING, DUBAI  
VHFL MINI FINGER PIER PROJECT  
132KV CABLE LAYING FOR DUBAL POT LINE 7, DUBAI  
CONTRACT 757/1A -  
PALM ISLAND INTERCHANGE ACCESS ROADS  
FEDERAL ELECTRICITY & WATER AUTHORITY PROJECT  
DORALEH BULK PRODUCTS TERMINAL, DJOUBITI

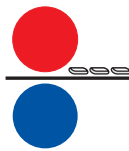

## DÜNYADA TEDARİKÇİSİ OLDUĞUMUZ FİRMALAR *The Companies Which We Supply Materials in Worldwide*

Компании, с которыми мы сотрудничаем по всему миру



**Sohar Industrial Supplies & Trading**  
PO Box : 1756 Postal Code :114  
Muttrah Sultane of Oman  
Tel: 00968-24491660 Fax: 00968-24491664



Petrofac Qatar W.L.L.  
P.O Box No: 4404 DOHA / QATAR  
TEL:+974 447 88 00 FAX:+974 447 88 11



Powerbreeze Engineering LTD. House No - 9/5,  
Lane No-1, Block-B Section - 6,  
MIRPUR, DHAKA-1216 BANGLADESH  
Tel: +88-02-8035388 Fax: +88-02-9014847  
<http://www.powerbreezxbd.com/>



ETS Caporal Et Moretti SAL  
125 Corniche Du Fleuve, Saphir Immobiliare Sal Bldg.  
BEIRUT-LEBANON  
TEL:+961-1-444555 FAX:+961-1-446688



**Enertec GMBH**  
Behrensstraße 19 – 21 50374 Erftstadt



**GRUPPA KOMPANI RS Group**  
129337, Moskow, Delovoi sentr «Tehnoplaza».  
yaroslavskoe sosse d.42,4 etaz  
Tel: +7(495) 627-55-05 Fax: +7(495) 627-55-06  
[www.rsys.ru](http://www.rsys.ru) e-mail:rs@rsys.ru

RAS AL KHOR CROSSING - CONTRACT R800/1  
RAS AL KHOR INTERCHANGE NO.1 (TEMPORARY DIVERSION) - CONTRACT R800/6  
CE/409C/2005 - SUPPLY, INSTALLATION, TESTING & COMMISSIONING OF 132/11KV SUBSTATION  
CONTRACT NO E05/05 SUPPLY, INSTALLATION, TESTING & COMMISSIONING OF 132/11KV SUBSTATION  
JEBEL ALI AIRPORT CITY PHASE 1A - JXB1/INF/010 (AIRFIELD AND INFRASTRUCTURE)  
JEBEL ALI AIRPORT CITY PHASE 1A - JXB1/INF/002 (RUNWAY 12/30 AND ASSOCIATED TAXI WAYS)  
JEBEL ALI AIRPORT CITY PHASE 1A - JXB1/INF/050  
JEBEL ALI AIRPORT CITY PHASE 1A - JXB1/INF/060  
AL HUSAM GENERAL CONTRACTING EST.- NEW CATALYST BCD80E FEEDING SYSTEM ON PE1 LINE IN  
RUWAI PETROCHEMICAL PLANT - BOROUGE/RUWAI  
AL NABOODAH CONSTRUCTION GROUP LLC - AL AHIL CLUB ACADEMY BUILDING  
AL HUSAM GENERAL CONTRACTING EST - NEW CATALYST BCD80E FEEDING SYSTEM ON PE1 LINE IN  
RUWAI PETROCHEMICAL PLANT - BOROUGE - RUWAI  
AL NABOODAH CONSTRUCTION GROUP LLC - AL AHIL CLUB ACADEMY BUILDING  
DANWAY ELECTRICAL & MECHANICAL ENGINEERING. - AD435 -  
GREEN ANODE PLANT & RODDING SHOP - EMAL  
DANWAY ELECTRICAL & MECHANICAL ENGINEERING. - AD444 - EMAL  
DANWAY ELECTRICAL & MECHANICAL ENGINEERING. - AD446 - EMAL  
DANWAY ELECTRICAL & MECHANICAL ENGINEERING. - AD417 - EMAL  
DANWAY ELECTRICAL & MECHANICAL ENGINEERING. - AD419A - EMAL  
DANWAY ELECTRICAL & MECHANICAL ENGINEERING. - AD426 - EMAL  
DHABI CONTRACTING / ATKINS DESIGN & CONSTRUCTION OF 786 RESIDENTIAL UNITS IN GHAYATHI  
CITY - WESTERN REGION - ABU DHABI GENERAL SERVICES COMPANY (MUSANADA)  
DNO MIDDLE EAST - TAWKE CPF (IRAQ) - IRAQ  
DNO MIDDLE EAST - HAWLER 2 (IRAQ) - IRAQ  
EMAL - ALUMINIUM SMELTER PROJECT - EMAL  
HYUNDAI / SAMSUNG JOINT VENTURE - BNPP PROJECT / DISTRIBUTED FOR REFERENCE - KEPCO  
ORION ENGINEERING CONSULTANTS - CONSTRUCTION OF WAREHOUSE AT JAFZA FOR DIESEL TECHNIC  
ME - AMANA STEEL BUILDING CONTRACTING.  
PARKWAY INTERNATIONAL CONTRACTING / ARIF & BINTOAK CONSULTANT  
JUMEIRAH PARK , DUBAI - DUBAI  
PETROFAC ( PETROLEUM FACILITIES E&C LIMITED KHOR MOR LPG Loading Facilities Repairs/Replacement  
Project - CRESCENT PETROLEUM DANA GAS, IRAQ  
SK ENGINEERING & CONSTRUCTION CO., LTD - TUFANBEYLI THERMAL POWER PLANT PROJECT -  
ENERJISA ENERGI URETIM A.S.  
SOHAR INDUSTRIAL SUPPLIES & TRADING RADISSON BLU SOHAR - OMAN  
TARPON INTERNATIONAL ENERGY SERVICES LLC - PETROCHAD - MANGARA/BADILA CHAD  
UNOIN CONTRACTING / A&Z ARCHITECTURAL ENG. - PROPOSED NMC HOSPITAL INTERIOR  
NMC HEALTH CARE  
Occidental Mukhaizna LLC - 240000041074 - OXY - OMAN  
ABB - CULTURE VILLAGE - SUBSTATION - DEWA  
ABB - DOHA ROAD - SUBSTATION - DEWA  
ABB - Pearl Jumeira substation - SUBSTATION DEWA  
ABB - BUSINESS BAY - SUBSTATION - DEWA  
MELCO - SUPPLY INSTALLTION, TESTING & COMMISSIONING OF STATIC VAR COMPENSATION STATIONS  
AT CARX SVC STATIONS DEWA  
MELCO - SUPPLY INSTALLTION, TESTING & COMMISSIONING OF STATIC VAR COMPENSATION STATIONS  
AT PDM - DEWA  
MELCO - SUPPLY INSTALLTION, TESTING & COMMISSIONING OF STATIC VAR COMPENSATION STATIONS  
AT NHDA - DEWA  
LARSEN & TOUBRO LIMITED (QATAR) - QATAR POWER TRANSMISSION SYSTEM EXPANSION PHASE-X  
SUBSTATIONS - KAHRAMAA

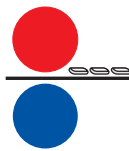

## DÜNYADA TEDARİKÇİSİ OLDUĞUMUZ FİRMALAR *The Companies Which We Supply Materials in Worldwide*

Компании, с которыми мы сотрудничаем по всему миру

### ENSYTEC

Ukraine, Kiev, st. Boryspilska 7, office 116  
tel/fax: +38(044)5006859  
info@ensytec.com.ua



Expert mondial des câbles et systèmes de câblage

4-10 rue Mozart, Le Christophe 2  
92587 Clichy cedex France



Schiemond 20-22 3002 AB  
Rotterdam Nederland www.croon.nl



Mana Control Co.  
www.manacontrol.com



Depac Enerji Sanayi ve  
Dış Ticaret Ltd Şti  
GSM: +9647506682020 <http://www.depac.ws>



### Polarvista

FLAT/ROOM 1208, KAI TAK  
COMMERCIAL BUILDING, 317-319  
DES VOEUX ROAD CENTRAL,  
HONG KONG

IRAQI LITE COMPANY FOR GENERAL CONTRACTS & ENG. CONSULTANTS CCR BUILDING AT BADRA OIL FIELD,  
REPUBLIC OF IRAQ " - Gazprom Neft"  
SOHAR INDUSTRIAL SUPPLIES & TRADING / CADAGUA -  
DARSAIT SEWAGE TREATMENT PLAN - HAYA WATER  
ARENA - PCIBV/2012/DD/279 - SKL & REPSOL  
AL FALAHY CO - PRIMARY SUBSTATION - MAZOOON ELECTRICITY COMPANY  
AL FUTTAIM CARILLION LLC - DUBAL CAST HOUSE - 3, DUBAI - DUBAL  
AL FUTTAIM CARILLION/ SNC LAVALIN - CATHOUSE 3 - DUBAL  
AL HAJIRY LLC - DAR AL MAHAA RESIDENTIAL COMPLEX - OMAN  
AL HAJIRY LLC - SIDHI WAREHOUSE - OMAN  
AL HASSAN ENGINEERING - 2x126MW AMAL POWER STATION - OMAN : PDO  
AL HASSAN ENGINEERING - LONG TERM POWER SUPPLY PROJECT - OMAN : OXY  
AL HASSAN ENGINEERING - QARN ALAM PROJECT - OMAN:PDO  
AL HASSAN ENGINEERING - ZAULIYAH GAS COMPRESSION PROJECT - OMAN:PDO  
AL HASSAN ENGINEERING - AMAL STEAM PROJECT - OMAN:PDO  
AL HASSAN ENGINEERING / GS E&C KOREA -  
SAIH NIHAYDA DEPLETION COMPRESSION (SNDC) PROJECT - OMAN:PDO  
AL HUSAM GENERAL CONTRACTING - AAD- OC0000- CORPORATE- SLGC C- 5001 T06-  
MECHANICAL AND PIPING AND MAJOR EQUIP. INST.  
AL HUSAM GENERAL CONTRACTING / SNC-LAVALIN GULF CONTRACTORS -  
TABREED DISTRICT COOLING PLANT - SAUDI ARABIA  
AL HUSAM GENERAL CONTRACTING / SNC-LAVALIN GULF CONTRACTORS -  
KING ABDULLAH FINANCIAL DISTRICT - SAUDI ARABIA  
AL HUSAM GENERAL CONTRACTING - BOILER REHABILITATION  
AL KHAIR TRADING CO. - ABU DHABI PROJECT, - UAE  
AL NABOODAH - JXB1/ INF/ 104A SEWAGE TREATMENT PLANT A - UAE:DUBAI CIVIL AVIATION  
AL NABOODAH - JXB1/ INF/ 104A SEWAGE TREATMENT PLANT A (CHECK LIST) - UAE:DUBAI CIVIL AVIATION  
AL NABOODAH/ DAR/ ADPI JV - APRONS AND ASSOCIATED  
TAXIWAYS JXB1/ INF/ 010 - UAE:DUBAI CIVIL AVIATION  
AL NABOODAH/ DAR/ ADPI JV - JXB1/INF/050 ROADS AND INFRASTRUCTURE -UAE:DUBAI CIVIL AVIATION  
AL NABOODAH/ DAR/ ADPI JV- JXB1/INF/060 PERIPHERAL ROADS - UAE:DUBAI CIVIL AVIATION  
AL NABOODAH/ DAR/ ADPI JV - RUNAWAY 12/ 30 AND  
ASSOCIATED TAXIWAYS JXB1/ INF/ UAE : DUBAI CIVIL AVIATION  
AL OMARAA COMPANY / SIEMENS KUWAIT - 33/11 KV SUBSTATION RIQA-M,  
ABDALY-N, SALMIYA-Q, JALEEB-M AND SHUWAIKH INDUSTRIAL AREA-M - KUWAIT : MEW  
AL OMARAA COMPANY / SIEMENS KUWAIT - 33/11 KV SUBSTATION RASS-M,  
RAWDATAIN TV-N AND SABAHYA-M - KUWAIT : MEW  
AL TURKI ENTERPRISES - ODC PROJECT - OMAN:PDO  
AATI CONTRACTS / CKR CONSULTING ENGINEERS - AREEJ - MALL OF EMIRATES - AL TAYER GROUP LLC  
AATI CONTRACTS / ESA ENGINEERING - PRADA - MALL OF EMIRATES - AL TAYER GROUP LLC  
ABB - 3X132/11KV SUBSTATIONS - DEWA CE/0716  
(AID CITY S/S, AL NAHDA S/S & TERMINAL 2 S/S) - UAE : DEWA  
ABB - FEWA E03 PROJECT (Corniche, Naimiya, Nakheel Old Town,  
Sawan & Sheria Substations) - UAE : FEWA  
ABB - 132/11KV SUBSTATION AT PEARL JUMEIRAH, DUBAI PARK LLC: MERAAS -  
DEVELOPMENT - UAE : DEWA  
ABB - DPG TATWEER PROJECT ( CULTURE VILLAGE, DOHA ROAD,  
BUSINESS BAY CREEK SUBSTATIONS) - UAE : DEWA  
ABB / PARSONS BRINKERHOFF (MIDDLE EAST) LIMITED - REZD/E/2008/1 - TATWEER DUBAILAND  
8X132/11KV SUBSTATIONS - DEWA / TATWEER DUBAILAND  
ACE ASSOCIATED CONSULTING ENGINEERS INTL/ HOTEL AND RESORTS -  
KINGDOM OF SHEBA - IFA

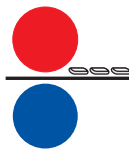

## DÜNYADA TEDARİKÇİSİ OLDUĞUMUZ FİRMALAR *The Companies Which We Supply Materials in Worldwide*

Компании, с которыми мы сотрудничаем по всему миру

### onninen

**Onninen Sp. z o.o.** ul. Emaliowa 28 02-295  
Warszawa Tel. +48 22 567 90 00  
Fax +48 22 567 90 09 info@onninen.pl

### NICSA

**Nicsa (Negocios Industriales y Comerciales, S.A.)**  
Paseo General Martínez Campos 15  
28010 - Madrid España  
Tel: (+34) 914 464 050 Fax: (+34) 914 483 767  
E-mail: nicsa@nicsa.abengoa.com



123995, Москва, Бережковская наб.  
дом 20, строение 5,  
info@omegaelectro.ru  
Tel: +7 (499) 678-81-09



238324 Калининградская обл.,  
Гурьевский р-н, Пос. Невское, ул.  
Совхозная, 3 Tel: . (4012) 777-045



### LOKYS



**Rainbow Machinery Solutions Pvt Ltd**  
S-3, Naveen Apartments, #10, 13th Main,  
Palace Road, Vasanthnagar, Bangalore - 560052  
+91 80 41611980

ACWA / DAR AL HANDASAH - SEWAGE TREATMENT PLANT 'A' - JEBEL ALI AIRPORT CITY PHASE 1 AIR FIELD AND INFRASTRUCTURE - DUBAI CIVIL AVIATION

AIR TRAFFIC CONTROL POWER/ DAR/ ADPI JV/ EFECO - JXB1/BLD/420 PHASE 1 - DUBAI CIVIL AVIATION

ALDERLEY FZE - ONGC - ONGC

ALSTOM - MARITZA EAST 1

ALSTOM - STAYTHROPE C CCGT POWER STATION (UK) - RWE N POWER

ALSTOM - MAROWE DAM PROJECT (SUDAN) - LAHMEYER INTERNATIONAL

ALSTOM - CYCOFOS PROJECT (FRANCE) - COFATHEC

ALSTOM - DUBAI GTX COGENERATION (FRANCE) - DUBAI

ALSTOM - MAROCCO PROJECT 400 KV(MAROCCO)

ALSTOM - ZAWIA EXTENSION (LIBYA)

ALSTOM - ALUAR PROJECT - ARGENTINA

ALSTOM - SYRIA PROJECT

ALSTOM - RELIZANE - 3 X 155 MW - ALSTOM POWER SYSTEMS

ALSTOM - ALSTOM POWER TURBO SYSTEM - KESTREL PROJECT, DUBAI - DUBAI

ALSTOM - ALSTOM POWER TURBO SYSTEM - KESTREL PROJECT II, DUBAI - DUBAI

ALSTOM - ALSTOM POWER ALBA POWER STATION 4, BAHRAIN - BAHRAIN ALUMINUM

ALSTOM - ALSTOM POWER CENTRALES CERNOVADA NUCLEAR POWER PLANT, ROMANIA

ALSTOM - HO PING COAL FIRED

ALSTOM - DERNIER HYDRO POWER PLANT (URFA), TURKEY

ALSTOM - DRIMRIVER HYDRO POWER PLANT, ALBABIE

ALSTOM - WASHASH GAS INSULATED, ADAMIYA AIR INSULATED, POWER SUBSTATIONS WASHASH, IRAQ

ALSTOM - CAN 2x160 MW CFB THERMAL POWER PLANT CANAKKALE, TURKEY

ALSTOM - ALSTOM BHT FACTORY STEELWORKS (CEDEX), FRANCE

ALSTOM - LAJANURI HYDRO POWER PLANT, GEORGIA

ALSTOM - NEHUENCO STEAM POWER PLANT, CHILE

ALSTOM - PHU MY COMBINED CYCLE POWER PLANT, VIETNAM

ALSTOM - N-11448-ASAB-2 TRANSCO 220KV SWITCHING STATION - TRANSCO / EBF

ALSTOM - N-11447-BAB-2 SUBSATATION - TRANSCO

ALSTOM / LAHMEYER INTERNATIONAL - NEW 400/132/33KV GIS AJMAN GRID STATION - TRANSCO

ALSTOM FRANCE - QATALUM - POWER GENERATION - QATALUM

ALSTOM / PB POWER LTD. - KURDISTAN - 132/33kv SS AT STAGE 6 IN DOHUK GOVERNORATE

KURDISTAN, IRAQ (MINISTRY OF ELECTRICITY)

ANEL TAAHHÜT - LINEADDECOR (ISTANBUL)

AQUATECH INTERNATIONAL CORPORATION - WATER TREATMENT PLANT -

PHASE 2 390K BWPD OF BOILER FEED WATER - OXY - OMAN

ARABIAN FALCON ELECTRICAL EQUIPMENT (L.L.C) / AL HUSAM GENERAL CONTRACTING ESTABLISHMENT -

TABREED COOLING PLANT - AD06 TABREED

AREVA T&D - GTC/144A/2006 QTSE - PHASE VIII PROJECT

(SUBSTATION) KAHRAMAA QATAR GENERAL ELECTRICITY & WATER CORPORATION

AREVA T&D - BARSHA & HORSE RACE - DUBAI - DEWA

AREVA T&D - APF PARAFODURE FACTORY, FRANCE

AREVA T&D - ERT MOROCCO PROJECT, CASABLANCA

AREVA T&D - DEWA CONTRACT CE716 - 8 SUBSTATIONS (SKLN, KFAF, BIRD, LBAC, KNWJ, MCLB & WSHP) -DEWA

AREVA T&D - DEWA CE/220A/2007 - DEWA

AREVA T&D - DUBAI BRANCH - TAKREER 5631 - TAKREER

AREVA T&D - DUBAI BRANCH - 132/22KV SUBSTATIONS AND ASSOCIATED WORKS AT PALM DEIRA - DEWA / NAKHEEL

ASCEN - CONSTRUCTION OF BOROUGE INNOVATION CENTRE IN ABU DHABI - ADNOC

ASCEN - INNOVATION CENTRE FOR BOROUGE IN ABU DHABI - ADNOC

AUDEUX PTE LTD - ENOC FUJAIRAH DISTRIBUTION & TRADING TERMINAL - ENOC

DRAKE & SCULL INTERNATIONAL LLC / M-ENGINEERING INC. - HATTA STAFF ACCOMODATION - BEL- YOAHA/ TCC



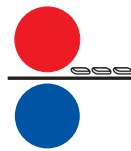

# DÜNYADA TEDARİKÇİSİ OLDUĞUMUZ FİRMALAR *The Companies Which We Supply Materials in Worldwide*

Компании, с которыми мы сотрудничаем по всему миру

**ALSTOM**  
**SIEMENS**

**Petrofac**

**SK E&C**

**ABB**

**SAMSUNG**  
SAMSUNG ENGINEERING

**Tecnimont ICB**

**Eni Saipem**

**AREVA**

**MITSUBISHI ELECTRIC**

**3M**

**SIDEM**

**THALES**

**DENGE**  
ENERGY LTD.

**SUN**

**SEA STAR**

**ARABIAN FALCON**

**Eurostrut**

**netzer**

**RV**

**PECYPC**  
**БАЗИС**

**RV**

**Eta-com**

**SIST**

**PETROFAC QATAR**

**POWER BREEZE**

**EMIRATES ELECTRICAL ENGINEERING LLC**

**TEKFEN**

**TEKFEN CONSTRUCTION**

**DANWAY**  
Electrical & Mechanical Engineering LLC

**ETA**

**EMIRATES ELECTRICAL ENGINEERING LLC**

**Kinden**  
**Kinden CORPORATION**

**KHARAFI NATIONAL DAR AL HANDASAH**

**EXTOL INTERNATIONAL LLC**

**rs**

**METITO (OVERSEAS LIMITED)**

BELHASA SIX CONSTRUCT / DANWAY ELECTRICAL & MECHANICAL -  
 CONTRACT R800/1-RAS AL KHOR CREEK CROSSING - DUBAI MUNICIPALITY / RTA  
 BIN DALMOUK CONSULTANT/ ENVICON EMIRATES/ NCC - 3B + G + 6 STORCY COMMERCIAL BUILDING  
 BIN HAFEEZ GENERAL CONSTRUCTION CO. DUBAI LLC/ DE LEUW CATHER OVERSEAS LTD/ PARSONS TRANSPORTATION GROUP  
 PALM ISLAND (JUMEIRA) ACCESS ROADS - DUBAI MUNICIPALITY  
 BIN HAFEEZ GENERAL CONTRACTING CO. / BESIX CONSTRUCT / ZENER ELECTRICAL  
 CONTRACT R757/1B - PALM ISLAND (JUMEIRAH) ACCESS ROAD, DUBAI -  
 DUBAI MUNICIPALITY / RTA  
 BK GULF - INGOT CASTING FACILITY, DUBAI - DUBAL  
 BK GULF - E&I WORKS FOR CAST HOUSE 3, DUBAI - DUBAL  
 CAPITAL COAST CONTRACTING LLC - R800/2 RAS AL KHOR CROSSING - RTA  
 CBI EASTERN ANSTALT - SHELL PEARL GTL TANKAGE - QATAR SHELL GTL LIMITED  
 CCC / ELSERVO - CNE/015/2002 JEBEL ALI POWER & DESALINATION STATION - L,  
 PHASE 1, DUBAI - DEWA  
 CENTAUR ELECTRO-MECHANICAL CONTRACTING CO. - INSTALLATION,  
 TESTING & COMMISSIONING OF 132/33KV SUBSTATION - FEWA  
 CENTAUR ELECTRO - MECHANICAL CONTRACTING CO. - FEWA  
 CHINA PETROLEUM ENGINEERING / EXTOL - ABU DHABI CRUDE OIL PIPELINE PROJECT HABSHAN- FUJAIRAH - IPIC  
 CHINA PETROLEUM / CONSILLIUM - VOPAK TERMINAL - FUJAIRAH - FEWA  
 CONVRGNT - JXB1/ BLD/440/441/442 FUEL STAGING AREA. FIRE STATION & POLICE FACILITIES -  
 PHASE 1 ANCILLARY BUILDINGS - DUBAI CIVIL AVIATION  
 CW SINGAPORE PTE LTD / COMPRA ENERGY S.A. - GAS LIFT COMPRESSION STATION - COMPRA ENERGY S.A.  
 DANWAY / ATKINS KEO INTERNATIONAL - AL SOWWAH ISLAND ROADS,  
 BRIDGES INFRASTRUCTURE WORKS PACKAGE PHASE-1 A,B & C  
 DANWAY / SNC - LAVALIN - EMAL CAST HOUSE - EMAL  
 DANWAY ELECTRICAL & MECHANICAL ENGINEERING -  
 HV/LV ELECTRICAL & INSTRUMENTATION WORKS FOR POT LINE 7, DUBAI - DUBAL  
 DANWAY ELECTRICAL & MECHANICAL ENGINEERING - HIGH BAY LIGHTING, DUBAI - DUBAL  
 DANWAY ELECTRICAL & MECHANICAL ENGINEERING - VHFL MINI FINGER PIER PROJECT FUJAIRAH VOPAC TERMINAL  
 DANWAY ELECTRICAL & MECHANICAL ENGINEERING - 132KV CABLE LAYING FOR DUBAL POT LINE 7, DUBAI - DUBAL  
 DANWAY ELECTRICAL & MECHANICAL ENGINEERING - IRM TRADING TERMINAL INSIDE FUJAIRA PORT - VOPAK HORIZON FUJAIRA LTD.  
 DANWAY ELECTRICAL & MECHANICAL ENGINEERING - CONTRACT 757/1A -  
 PALM ISLAND INTERCHANGE ACCESS ROADS - DUBAI MUNICIPALITY  
 DANWAY ELECTRICAL & MECHANICAL ENGINEERING - FEDERAL ELECTRICITY & WATER AUTHORITY PROJECT - FEWA  
 DANWAY ELECTRICAL & MECHANICAL ENGINEERING - DORALEH BULK PRODUCTS TERMINAL, DJOUBITI - ENOC  
 DANWAY ELECTRICAL & MECHANICAL ENGINEERING - RAS AL KHOR CROSSING - CONTRACT R800/1 - RTA  
 DANWAY ELECTRICAL & MECHANICAL ENGINEERING - RAS AL KHOR INTERCHANGE NO.1 (TEMPORARY DIVERSION) -  
 CONTRACT R800/6 - RTA  
 DANWAY ELECTRICAL & MECHANICAL ENGINEERING - CE/409C/2005 - SUPPLY,  
 INSTALLATION, TESTING & COMMISSIONING OF 132/11KV SUBSTATION - DEWA  
 DANWAY ELECTRICAL & MECHANICAL ENGINEERING - CONTRACT NO E05/05 SUPPLY,  
 INSTALLATION, TESTING & COMMISSIONING OF 132/11KV SUBSTATION - FEWA  
 DANWAY ELECTRICAL & MECHANICAL ENGINEERING - REINFORCEMENT OF 1/0,  
 4KV DISTRIBUTION SUBSTATION IN ABU DHABI LOT 2-11KV SWITCHING STATION IN UMM AL NAR - PB POWER/ ADDC  
 DANWAY ELECTRICAL & MECHANICAL ENGINEERING / AL FUTTAIM CARILLION - EMAL CG5460: MAINTENANCE SHOP, CATHODE SEALING,  
 POT LINING FACILITIES - EMAL  
 DANWAY ELECTRICAL & MECHANICAL ENGINEERING / AL NABOODAH CIVIL ENGINEERING DIVISION - JEBEL ALI AIRPORT CITY PHASE  
 1A - JXB1/INF/010 (AIRFIELD AND INFRASTRUCTURE) - DUBAI CIVIL AVIATION  
 DANWAY ELECTRICAL & MECHANICAL ENGINEERING / AL NABOODAH CIVIL ENGINEERING DIVISION - JEBEL ALI AIRPORT CITY PHASE  
 1A - JXB1/INF/002 (RUNWAY 12/30 AND ASSOCIATED TAXI WAYS) - DUBAI CIVIL AVIATION  
 DANWAY ELECTRICAL & MECHANICAL ENGINEERING / AL NABOODAH CIVIL ENGINEERING DIVISION - JEBEL ALI AIRPORT CITY PHASE  
 1A - JXB1/INF/050 - DUBAI CIVIL AVIATION



# DÜNYADA TEDARİKÇİSİ OLDUĞUMUZ FİRMALAR *The Companies Which We Supply Materials in Worldwide*

Компании, с которыми мы сотрудничаем по всему миру



DANWAY ELECTRICAL & MECHANICAL ENGINEERING / AL NABOODAH CIVIL ENGINEERING DIVISION - JEBEL ALI AIRPORT CITY PHASE 1A - JXB1/INF/060 - DUBAI CIVIL AVIATION

DANWAY ELECTRICAL & MECHANICAL ENGINEERING / CONSULT- MAUNSELL - AECOM - R-885 :COMPREHENSIVE IMPROVEMENT TO ITTIHAD ROAD (PHASE II) - RTA

DANWAY ELECTRICAL & MECHANICAL ENGINEERING / NATIONAL WHEEL J&P LLC -DUBAI INTERNATIONAL AIRPORT CITY EXPANSION (PHASE II) AX 304- EK OPERATION CENTER TUNNEL - DUBAI CIVIL AVIATION

DANWAY ELECTRICAL & MECHANICAL ENGINEERING. - REPLACEMENT OF GAS MONITORING SYSTEM FOR GAS OIL TREATMENT PLANT AND TRUCK LOADING PLANT AT ABU DHABI REFINERY - TAKREER

DANWAY ELECTRICAL & MECHANICAL ENGINEERING/ PARSONS DE LEUW CATHER OVERSEAS LIMITED - DUBAI AIRPORT ROADS IMPROVEMENTS PHASE II - RTA

DANWAY ELECTRICAL & MECHANICAL ENGINEERING/ AL NABOODAH SOWWAH ISLAND ROADS, BRIDGES INFRASTRUCTURE WORKS PACKAGE PHASE 1- A, B & C - ATKINS/ KEO

DANWAY ELECTRICAL AND MECHANICAL - CE/ 409C/ 2005 SUPPLY, INSTALLATION, TESTING AND COMMISSIONING OF 132/ 11KC SUBSTATION & ASSOCIATE WORKS FOR DUBAI SILICON OASIS S/ S - DEWA

- 1. DIŞ HATLAR TERMİNALİ / ANTALYA
- 1. HES DARICA / ORDU
- 3H HAVALİMANI / ÖZBEKİSTAN
- 42 MASLAK KONUT-OFİS-AVM / İSTANBUL
- 9 EYLÜL ÜNİVERSİTESİ GENEL KÜTÜPHANESİ / İZMİR
- A1 AVM / ANKARA
- **ADALYA OCEAN OTEL / ANTALYA**
- ADAM & EVE OTEL / ANTALYA
- ADANUS TOWERS KARTAL / İSTANBUL
- **ADIGÜZEL HES / DENİZLİ**
- **ADNAN MENDERES HAVALİMANI / İZMİR**
- AFYON SPOR KOMPLEKSİ / AFYON
- **AGT AĞAÇ SAN / ANTALYA**
- **AĞAOĞLU AYAZMA ŞANTİYESİ / İST**
- AKASYA ACIBADEM KONUT+AVM / İSTANBUL
- **AKASYA HACIBADEM**
- AKBANK OPERASYON MERKEZİ / İSTANBUL
- AKBANK T.A.Ş. ŞUBELERİ (TÜRKİYE GENELİ)
- AKGÜN GIDA / İSTANBUL
- AKKOZA-2 KONUTLARI / İSTANBUL
- **AKS YAPI LOBİ TUZLA / İST**
- **AKS YAPI SARISSA EVLERİ ÜMRANİYE / İST**
- AKTEKS TEKSTİL FABRİKASI / BURSA
- ALBARAKA ŞUBELERİ (TÜRKİYE GENELİ)
- **ALEMDAR KİMYA DİLOVASI / KOCAELİ**
- ALGIDA DONDURMA FABRİKASI / TEKİRDAĞ
- ALİNMAA OFİS / LİBYA
- **ALİ İHSAN TÜZÜN İŞ MERKEZİ SAMANDIRA / İST**
- **ALVA DONNA HOTEL / ANTALYA**
- ALMAATA HAVAALANI / TÜRKMENİSTAN
- ALMONDHİLL KONUTLARI / İSTANBUL
- ALTİNOVA ÇİMENTO FABRİKASI / ELAZIĞ
- AMBARLI TERMİK SANTRALİ / İSTANBUL
- AMBASSADOR HOTEL / ANTALYA
- AMMARA HASTANESİ / IRAK
- ANADOLU YALDIZ / İSTANBUL
- ANAYAPI PLAZA KOZYATAĞI / İSTANBUL
- ANKARA TED KOLEJİ
- ANTALYA HAVAALANI
- **ANTALYA ORG.SAN.BÖL. İDARE BİNASI VE SOS.TESİS. / ANTALYA**
- AREVA GEBZE / KOCAELİ
- ARI-3 TEKNOKENT(İTÜ MASLAK KAMP.) / İSTANBUL

- ARISTA BOMONTI / İSTANBUL
- ARTVİN HES PROJESİ
- ASSAN ALÜMİNYUM / İSTANBUL
- **ASIA RAMADA OTEL**
- ATAŞEHİR DELUXIA KONUTLARI / İSTANBUL
- **ATAKAŞ MAKİNA OSB GEBZE / KOCAELİ**
- ATATÜRK HAVALİMANI İÇ VE DIŞ HATLAR TERMİNALİ / İSTANBUL
- ATİK PAŞA YALISI / İSTANBUL
- AVEA GÜNEŞLİ / İSTANBUL
- AVRUPA KONUTLARI ISPARTAKULE / İSTANBUL
- AYSİR KEMPİNSKI HOTEL / MUĞLA
- BABY GİZ PLAZA MASLAK / İSTANBUL
- **BAĞIŞTAŞ HES / ERZİNCAN**
- BAK KADIN DOĞUM HASTANESİ / IRAK
- BAKÜ-TİFLİS-CEYHAN BORU HATTI
- BANDIRMA BOR VE ASİT FABRİKALARI / BALIKESİR
- BARIŞ KOZMETİK TEKSTİLKENT / İSTANBUL
- BARUT SUNWING HOTEL / ANTALYA
- BARZAN HASTANESİ / IRAK
- BASRA HASTANESİ / IRAK
- **BAŞBAKANLIK HİZMET BİNASI / ANKARA**
- BATI ATAŞEHİR KENT PLUS / İSTANBUL
- BATI ŞEHİR KONUT-OFİS-OTEL / İSTANBUL
- BATUMİ GEORGIA AIRPORT / GÜRCİSTAN
- BEACH CLUB / COLOMBIA
- **BELAZUR RESORT & SPA / ANTALYA**
- BERA OTEL / ANTALYA
- BEYBİ ELDİVEN FABRİKASI / BURSA
- BİLİM İLAÇ GEBZE / KOCAELİ
- BJK Selenium / İSTANBUL
- BORUSAN GENEL MÜDÜRLÜK / İSTANBUL
- BOSEN ENERJİ / BURSA
- BOYTEKS TEKSTİL / BURSA
- BRİSA LASTİK SANAYİ FABRİKASI / KOCAELİ
- BURSARAY / BURSA
- **BU YAKA AVM ÜMRANİYE / İST**
- CAŞABA ÖMERLİ VİLALARI / İSTANBUL
- CEBİR TEKSTİL / İSTANBUL
- CENGİZ TOPEL ASKERİ HAVAALANI / KOCAELİ
- CETAŞ KUYUMCULUK / İSTANBUL
- CEVAHİR AVM / İSTANBUL
- **CHIPITA GEBZE FABRİKASI / KOCAELİ**

- CLUB MEGA SARAY / ANTALYA
- CLUB PACİFİC HOTEL / ANTALYA
- CLUB VOYAGE / MUĞLA
- COCO COLA ÇORLU TESİSLERİ / TEKİRDAĞ
- CONCORDE RESORT & SPA / ANTALYA
- CRYSTAL HOTEL / ANTALYA
- CRYSTAL NİRVANA RESORT / ANTALYA
- CRYSTAL SUNSET RESORT & SPA / ANTALYA
- CRYSTAL HOTELS GREEN BAY OTEL / MUĞLA
- CRYSTAL WATERWORLD HOTEL / ANTALYA
- CVK PARK OTEL TAKSİM / İSTANBUL
- ÇANAKKALE İLAHİYAT FAKÜLTESİ / ÇANAKKALE
- ÇARŞAMBA HAVAALANI / SAMSUN
- ÇERMİKLER HES / SİVAS
- ÇİFTÇİ TOWERS / İSTANBUL
- DAP ROYAL CENTER / İSTANBUL
- DEĞİRMEN HES / TRABZON
- DENSO OTOMOTİV YAN SANAYİ FAB. / KOCAELİ
- DEŞARJ-ARITMA TESİSLERİ / İZMİR
- DEÜ TINAZTEPE KAMPÜSÜ / İZMİR
- DHI MERZİFON HAVAALANI / AMASYA
- DEVA HOLDİNG / İSTANBUL
- DHMİ ADIYAMAN HAVAALANI
- DIŞ HASTANESİ / TÜRKMENİSTAN
- DİONİS OTEL RESORT / ANTALYA
- DOĞADAN GIDA / İZMİR
- DOĞUŞ POWER CENTER AVİM / İSTANBUL
- DONGHEE HENDEK / SAKARYA
- DORA 3 JES / AYDIN
- DOSU MAYA FABRİKASI / İSTANBUL
- DMY İŞ MERKEZİ ÜMRANİYE / İST
- DR. TARSA TARIM A.Ş. / ANTALYA
- DUMANKAYA ADRES PANORAMA / İSTANBUL
- DUMANKAYA CADDE / İSTANBUL
- DUMANKAYA FLEX KURTKÖY / İST
- DUMANKAYA KONSEPT HALKALI / İST
- DUMANKAYA MODERN VADİ ESENYURT / İST
- DUMANKAYA PANORAMA TUZLA / İST
- DUMANKAYA RİTİM MALTEPE / İST
- DUMANKAYA FLEX / İSTANBUL
- DÜZCE ÜNİVERSİTESİ
- ECZACIBAŞI KANYON AVİM / İSTANBUL

- EFES -SWISS OTEL / İZMİR
- EFEMÇUKURU ALTIN MADENİ / İZMİR
- EGEBOYU KONUTLARI SANCAKTEPE / İST
- EKİN PANO / BURSA
- EKSUN GIDA FABRİKASI / TEKİRDAĞ
- ELBA GEBZE FABRİKASI / KOCAELİ
- ENERJİ-SA / KOCAELİ
- ENERJİSA BANDIRMA DOĞALGAZ SANTRALİ / BALIKESİR
- ENTEK TERMİK SANTRALİ / KOCAELİ
- EREĞLİ DEMİR ÇELİK FABRİKASI / ZONGULDAK
- ESENBOĞA HAVAALANI / ANKARA
- ESENLER OTOGARI / İSTANBUL
- ESENTAİ PARK SHOPPING MALL / KAZAKİSTAN
- ESENTAİ TOWER / KAZAKİSTAN
- ESKİŞEHİR ENERJİ ÜRETİM A.Ş. / ESKİŞEHİR
- ESPRİ OUTLET AVİM / İSTANBUL
- EVORAPARK KONUTLARI / İSTANBUL
- EXPO CENTER HANT MANSISKY / RUSYA
- EZİNE RES / ÇANAKKALE
- FATİH SPOR KOMPLEKSİ / İSTANBUL
- FATİH ÜNİVERSİTESİ / İSTANBUL
- FİNANSBANK A.Ş. ŞUBELERİ (TÜRKİYE GENELİ)
- FLORYA AKVARYUM / İST
- FORD DİNAMOMETRE / KOCAELİ
- FORD OTOSAN GÖLCÜK / KOCAELİ
- FORD OTOSAN KAYNAK BİNASI / KOCAELİ
- FORUM AVİM / TRABZON
- FORUM AVİM BAYRAMPAŞA / İSTANBUL
- FOUR SEASONS HOTEL / İSTANBUL
- FOUR WINDS RESIDENCE / İSTANBUL
- GALERİ KRİSTAL A.Ş. ANTALYA
- GARANTİ AKKOZA KONUTLARI / İSTANBUL
- GERMENCİK JES / AYDIN
- GLORİA GOLF OTEL / ANTALYA
- GLORİA SERENİTY OTEL / ANTALYA
- GLORİA VERDE HOTEL / ANTALYA
- GM-OPEL / RUSYA
- GRAND CEVAHİR HOTEL / İSTANBUL
- GRAND TARABYA HOTEL / İSTANBUL
- GRAND PARK / ANTALYA
- GÜBRETAŞ GÜBRE FABRİKALARI / KOCAELİ
- GÜLBAHAR PLASTİK / ANTALYA



- GÜMÜŞSUYU OTEL / İST
- GÜNAY KALIP / İSTANBUL
- GÜNEY PLAZA / İSTANBUL
- GÖKNUR GIDA MEYVE SUYU FAB. / AFYON
- GÖKTÜRK ARCADIUM / İST
- GÜZELOLUK HES / GÜMÜŞHANE
- HABOM SABİHA GÖKÇEN HAVAALANI / İSTANBUL
- HALIÇ METROGEÇİŞ KÖPRÜSÜ / İST
- HANTY SPOR KOMPLEKSİ / RUSYA
- HASANBEYLİ RES / OSMANİYE
- HAYAT KİMYA FABRİKASI / KOCAELİ
- HAYRİ SIVRIKAYA HASTANESİ / DÜZCE
- HİLLA HASTANESİ / IRAK
- HİLTON GARDEN INN / KÜTAHYA
- HOLIDAY INN AIRPORT NORTH HOTEL / İSTANBUL
- HOLIDAY INN OTEL ŞİŞLİ / İSTANBUL
- HOTEL TERRACE BEACH RESORT / ANTALYA
- HSBC KAVACIK / İSTANBUL
- HYOSUNG İSTANBUL TEKSTİL / TEKİRDAĞ
- IBIS HOTEL ZEYTİNBURNU / İSTANBUL
- ISPARTA HAVAALANI
- ISPARTAKULE -3 KONUTLARI / İSTANBUL
- IŞIK ÜNİVERSİTESİ ŞİLE KAMPÜSÜ / İSTANBUL
- IŞIL TEKSTİL / TEKİRDAĞ
- İÇKALE HOTEL / ANKARA
- İLİÇ ÇÖPLER ALTIN MADENİ / ERZİNCAN
- İPEK KAĞIT / YALOVA
- İNNOVİA ISPARTA KULE / İST
- İNNOVİA KONUTLARI BEYLÜKDÜZÜ / İST
- İSDEMİR 4 NOLU KOK BATARYASI / HATAY
- İSKİ ÖMERLİ / İSTANBUL
- İSTANBUL TEKSTİL VE KONF. İHR. BİR. / İSTANBUL
- İSTANBUL SARAYLAR PROJESİ / İST
- İŞ BANKASI GENEL MÜDÜRLÜK BİNASI / İSTANBUL
- İŞ BANKASI OPERASYON MERKEZİ / İSTANBUL
- İŞ BANKASI ŞUBELERİ (TÜRKİYE GENELİ)
- İZMİR OTOGARI / İZMİR
- KAHİRE HAVAALANI / MİSİR
- KALE HOME CENTER AVM / İSTANBUL
- KALE HES / KARS
- KALİNGRAD AVM / RUSYA
- KASTAMONU ENTEGRE FABRİKASI / ADANA

- KASTAMONU ENTEGRE / KASTAMONU
- KASTAMONU ENTEGRE FABRİKASI / BALIKESİR
- KASTAMONU ENTEGRE FABRİKASI / KOCAELİ
- KASTAMONU ENTEGRE FABRİKASI / SAMSUN
- KASTAMONU ENTEGRE FABRİKASI / TATARİSTAN
- KARTAL MAİ PROJESİ / İST
- KAVACIK GÜLSAN PLAZA / İSTANBUL
- KAYAŞEHİR HİLTON HOTEL / İSTANBUL
- KAYI GRUP PLAZA / ANTALYA
- KAYSERİ ŞEKER FABRİKASI / KAYSERİ
- KELETE ÇİMENTO FABRİKASI / TÜRKMENİSTAN
- KEMERÇAYIR / TRABZON
- KEMPİNSKİ HOTEL THE DOME / ANTALYA
- KIBRIS ÜNİVERSİTESİ / KKTC
- KIŞLADAĞ ALTIN MADENİ / UŞAK
- KIYI EMNİYET GENEL MÜD. FLORYA / İSTANBUL
- KİEV BORYSPİL HAVAALANI / UKRAYNA
- KİRAZLIK HES / SİİRT
- KİPTAŞ MALTEPE BAŞIBÜYÜK KONUTLARI / İSTANBUL
- KOCAELİ ÜNİVERSİTESİ ARAŞTIRMA HASTANESİ
- KOCAELİ ÜNİVERSİTESİ MORFOLOJİ BİNASI
- KOÇTAŞ GEBZE / KOCAELİ
- KONYA HAVALİMANI / KONYA
- KOLİN OTEL TUZLA / İSTANBUL
- KORDSA İPLİK / KOCAELİ
- KORUMA KLOR ALKALİ / KOCAELİ
- KOSİFLER İŞ MERKEZİ / İSTANBUL
- KOZYATAĞI STARGATE KONUTLARI / İSTANBUL
- KULELİ ASKERİ LİSESİ / İSTANBUL
- KURUKAHVECİ MEHMET EFENDİ FABRİKASI / İSTANBUL
- KUYUCAK RES / MANİSA
- KUYUMCUKENT / İSTANBUL
- KRİSTAL ŞEHİR / İST
- KRİSTAL TAT BEACH OTELI / ANTALYA
- LA BLANCHE RESORT & SPA / MUĞLA
- LAPINO HOSPITAL MOSKOVA / RUSYA
- LEVENT LOFT / İSTANBUL
- LİMAK ATLANTİS HOTEL / ANTALYA
- LİNEA DEKOR FABRİKASI / KOCAELİ
- LONG BEACH OTEL / ANTALYA
- LOTTE HOTEL / RUSYA
- MAÇKA TM HES / TRABZON

- MALTEPE CARREFOUR / İSTANBUL
- MARKS&SPENCER MAĞAZALARI (TÜRKİYE GENELİ)
- MARRIOTT HOTEL ŞİŞLİ / İSTANBUL
- MARMARA ÜNİVERSİTESİ HASTANESİ 650 YATAKLI /İST
- MASLAK 42 / İST
- MASLAK VADİ KONAKLARI / İSTANBUL
- MAVİ HES VE REGÜLATÖRÜ / TRABZON
- MAZI LAND RESIDENCE / IRAK
- MEDENİ DİNÇ AVM / TÜRKMENİSTAN
- MEHTAP MUTFAK EŞYALARI / İSTANBUL
- MERCEDES HADIMKÖY / İSTANBUL
- MERSİN 400 YATAKLI ÜNİVERSİTE HASTANESİ / MERSİN
- METRANS DEPO GEBZE /KOCAELİ
- METRO GROSSMARKET BAYRAMPAŞA / İSTANBUL
- METRO GARDEN / İST
- MİGROS MAĞAZALARI (TÜRKİYE GENELİ)
- MİLLİ EĞİTİM BAKANLIĞI FATİH PROJESİ
- MİLLİYET GAZETESİ ANKARA BÖLGE MÜDÜRLÜĞÜ
- MODERN AMBALAJ GEBZE FABR./ KOCAELİ
- MOSTBANK MOSKVA / RUSYA
- MUĞLA ÜNİVERSİTESİ
- MY HOME MASLAK / İSTANBUL
- NİSSA O2 RESIDANCE / İSTANBUL
- NOBELFARMA İLAÇ FABRİKASI / DÜZCE
- NOVADA ATAŞEHİR / İSTANBUL
- NUH ÇİMENTO FABRİKASI / KOCAELİ
- NUROL TOWER / İST
- OBARİ ENERJİ SANTRALİ / LİBYA
- OBİ-KAZAN / TATARİSTAN
- ONKOLOJİHASTANESİ MALTEPE / İST
- OLİMPİYAT KOMPLEKSİ / TÜRKMENİSTAN
- OPET MARMARA EREĞLİSİ / TEKİRDAĞ
- ORA AVM / İSTANBUL
- ORMANADA ZEKERİYAKÖY / İSTANBUL
- OSMANLI ÇARŞISI / İSTANBUL
- OYLAT HES / BURSA
- ÖZCANLAR TEKSTİL / TEKİRDAĞ
- ÖZDİLEK LEVENT AVM / İSTANBUL
- ÖZEL MALATYA HASTANESİ / MALATYA
- ÖZKA LASTİK VE KAUCUK SAN./ KOCAELİ
- ÖZKAN DEMİRCİLİK / İZMİR

- ÖZTOPRAK SERACILIK / ANTALYA
- ÖZÜNVER KAUCUK / BURSA
- PAMUKKALE TEKNOKENT / DENİZLİ
- PAKMAYA FABRİKASI / KOCAELİ
- PALACE HOTEL TIFLİS / GÜRCİSTAN
- PALMIYE OTELİ & TATİL KÖYÜ / ANTALYA
- PAPIRUS PLAZA / İSTANBUL
- PFIFFNER TRANSFORMATÖR FAB. / ANK.
- PLAST-MET KALIP / İSTANBUL
- POLYPLEX EUROPA POLYESTER / TEKİRDAĞ
- PRESMETAL OTOMOTİV / BURSA
- PRIME MALL AVM / GAZİANTEP
- RADIOTHERAPY HOSPITAL / IRAK
- RADISSON BLU OTEL TAKSİM / İSTANBUL
- RAMADA OTELİ ALTUNİZADE / İST
- RAMADA HOTEL ŞİŞLİ / İSTANBUL
- RAMADA OTEL GEBZE / KOCAELİ
- RAMADA OTEL İZMİT / KOCAELİ
- RAMADİ HASTANESİ / IRAK
- RAMSTORE MALL / KAZAKİSTAN
- REGNUM CARYA GOLF OTEL / ANTALYA
- REDEVCO MAGNESİA AVM / MANİSA
- RENOVA LOT 1-2-3 / GÜRCİSTAN
- RİXOS PERA OTEL / İSTANBUL
- RKB HASTANESİ / MOLDOVA
- ROMA BEACH RESORT OTEL / ANTALYA
- ROTOPAK MATBAACILIK / İSTANBUL
- ROYAL ALHAMBRA PALACE HOTEL / ANTALYA
- ROYAL WING OTELS / ANTALYA
- RUSSKY STANDART VODKA FABRİKASI / RUSYA
- RÜZGARLI BAHÇE ASAŞ İŞ MERKEZİ BEYKOZ / İST
- SABİHA GÖKÇEN HAVAALANI / İSTANBUL
- SAFİSA İSTANBUL PALACE OTEL / ANTALYA
- SAKHALIN NATURAL GAS STATION / RUSYA
- SAKO-SA / KOCAELİ
- SALEKHARD COLLEGE / RUSYA
- SALEKHARD HASTANESİ / RUSYA
- SAMURLU RES MENEMEN / İZMİR
- SARAY GRUP REZİDANS &OTEL VE TİCARET MERK GÜNEŞLİ /İST
- SARCHEM BOYA VE LAK FABRİKASI / İST.
- SARISSA EVLERİ / İSTANBUL



- SAYALAR-2 RES / MANİSA
- SEDEF TERSANESİ TUZLA / İSTANBUL
- SEKİSO OTOMOTİV GEBZE / KOCAELİ
- SELENIUM PANAROMA / İSTANBUL
- SETİF PARK MALL / CEZAYİR
- SETUR AYVALIK MARİNA / BALIKESİR
- SERAP HES / KARS
- SERUM FABRİKASI / TÜRKMENİSTAN
- SHAKE SHACK TUNEL PROJESİ
- SHERATON OTEL / ADANA
- SHAKHTAR DONETSK STADYUMU / UKRAYNA
- SHANGRI-LA BOSPHORUS HOTEL / İSTANBUL
- SİDE BELEDİYESİ HİZMET BİNASI / ANTALYA
- SİNPAŞ ANTEPİA / GAZİANTEP
- SİNPAŞ EGEBOYU SANCAKTEPE / İSTANBUL
- SİNPAŞ GYO BOSPHORUS CİTY / İSTANBUL
- SİRENE DAVRAS MOUNTAIN RESORT / ISPARTA
- SİRTE OTEL / LİBYA
- SOFYA HAVAALANI / BULGARİSTAN
- SOYAK EVOSTAR / İSTANBUL
- SOYAK PARK APARTS / İSTANBUL
- SPICE HOTEL / ANTALYA
- SUN PLAZA / İSTANBUL
- ŞEN PİLİÇ KESİM HANE SÖĞÜTLÜ / SAKARYA
- ŞİŞE CAM ARGE BİNASI
- ŞİŞE CAM FABRİKASI / BURSA
- ŞİŞLİ KOLAN HASTANESİ / İSTANBUL
- ŞİŞLİ KÜLTÜR MERKEZİ / İSTANBUL
- ŞİŞLİ PLAZA / İSTANBUL
- TAV YER ALTI OTOPARKLARI AKSARAY / İST
- TAEGUTEC KESİCİ TAKIMLAR FAB. / KOCAELİ
- TEKFEN ÖZ KAĞITHANE OFİSLERİ / İSTANBUL
- TEKFEN TOWER / İSTANBUL
- TEKNİK SAÇ KAYNAK VE LEHİM LTD. / İSTANBUL
- TEKNOGON ÇERKEZKÖY FABRİKASI / TEKİRDAĞ
- TEKNOPARK KURTKÖY / İSTANBUL
- TERAS TEMA HALKALI / İSTANBUL
- THE PLAZA HOTEL / İSTANBUL
- TOKİ / GAZİANTEP
- TOKİ / İZMİR

- TOKİ HALKALI / İSTANBUL
- TOKİ KAYABAŞI KONUTLARI / İSTANBUL
- TOSYALI DEMİR ÇELİK FABRİKASI / CEZAYİR
- TRAKYA CAM FABRİKASI / KIRKLARELİ
- TURKCELL MALTEPE BİNASI / İST
- TURKCELL (TÜRKİYE GENELİ)
- TURKCELL VAN OMC BİNASI / VAN
- TURKON HOLDİNG ALTUNİZADE / İSTANBUL
- TURKUVAZ OTEL & TATİL KÖYÜ / MUĞLA
- TÜPRAŞ RAFİNERİSİ / İZMİR
- TÜPRAŞ İLK ÖĞRETİM OKULU / KOCAELİ
- TÜRKMENİSTAN DEVLET ETALON MERKEZİ
- TÜRKMENİSTAN ENERJİ BAKANLIĞI
- UMURBEY ORDONAT KOMUTANLIĞI / ÇANAKKALE
- UKRA CITY / İSTANBUL
- UNİLEVER TÜRK A.Ş. / KOCAELİ
- ÜÇANLAR HES / TRABZON
- ÜÇARMANLAR HES / TRABZON
- ÜNVER PLAZA / İSTANBUL
- VADİ İSTANBUL PROJESİ
- VAKIFBANK GENEL MÜDÜRLÜĞÜ / İSTANBUL
- VALLE LOCUS BÜYÜKÇEKMECE / İSTANBUL
- VENÜS OTEL / ANTALYA
- VEHBİ KOÇ VAKFI GÖLCÜK EĞİTİM MRK. / KOCAELİ
- VIALAND KOÇTAŞ / İST
- VINERO ŞARAP FABRİKASI ECEBAT / ÇANAKKALE
- VİLAYET HASTANESİ / TÜRKMENİSTAN
- VODAFONE (TÜRKİYE GENELİ)
- YAPI MERKEZİ ÇAYCUMA - ANKARA TUNEL VE KÖPRÜ HATLARI
- YAMANLI HES / ADANA
- YENİ KAPI TAKSİM METRO İNŞAATI / İST
- WATER PLANET HOTEL&AQUAPARK / ANTALYA
- WEST BLOKS / İSTANBUL
- YAZAKİ OTOMOTİV / BURSA
- YILDIZLAR SU ÜSTÜ EĞİTİM MERKEZİ / KOCAELİ
- YOLETEN PROJESİ / TÜRKMENİSTAN
- YÜCEL BORU / KOCAELİ
- ZAFER HAVAALANI / KÜTAHYA
- ZONGULDAK ATIKSU ARITMA TESİSİ
- ZORLU KIZILDERE 2. JES / DENİZLİ

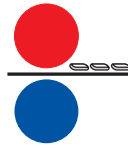

**TÜRK STANDARDLARI ENSTİTÜSÜ**  
**TÜRK STANDARDLARINA UYGUNLUK BELGESİ**  
**TURKISH STANDARDS INSTITUTION**  
**CERTIFICATE OF CONFORMITY TO TURKISH STANDARDS**

Markanın Tanımı Description of the Mark  
**TSE** veya/or  veya/or **T S E**

<b>BELGE NUMARASI</b> REFERENCE NUMBER OF LICENCE	14.0.30.4.34.00/TSE-64435
<b>BELGENİN İLK VERİLİŞ TARİHİ</b> DATE OF FIRST ISSUE OF LICENCE	16.04.2013
<b>BELGENİN SON GEÇERLİLİK TARİHİ</b> LICENCE VALID UNTIL	16.04.2014
<b>BELGE SAHİBİ KURULUŞUN ADI</b> NAME OF THE LICENCE HOLDER	GERSAN ELEKTRİK TİCARET VE SANAYİ A.Ş.
<b>BELGE SAHİBİ KURULUŞUN ADRESİ</b> ADDRESS OF THE LICENCE HOLDER	TUZLA MERMERCİLER ORGANİZE SAN. BÖL. GAZİ BULVARI NO:37-39-41 TUZLA İSTANBUL
<b>ÜRETİM YERİ ADI</b> NAME OF THE MANUFACTURING PLACE	GERSAN ELEKTRİK TİC. VE SAN. A.Ş.
<b>ÜRETİM YERİ ADRESİ</b> ADDRESS OF THE MANUFACTURING PLACE	ORG.SAN.BÖLG.1 NOLU OSB.MEYDANI 1.CADDE 6. VE 7. SOK. ÇAYCUMA/ ZONGULDAK
<b>İPTAL EDİLEN BELGE NUMARASI (Varsa)</b> INDICATION OF SUPERSEDED LICENCE (if any)	
<b>TESCİLLİ TİCARİ MARKASI</b> REGISTERED TRADE MARK	GERSAN
<b>İLGİLİ TÜRK STANDARDI</b> RELATED TURKISH STANDARD	TS EN 61537 / Kablolar -Kablo tesisi için - Kablo tava sistemleri ve kablo merdiven sistemleri / 26.06.2007
<b>BELGE KAPSAMI</b> SCOPE OF LICENCE	

TS EN 61537 HAZİRAN/2007 "KABLOLAR-KABLO TESİSİ İÇİN-KABLO TAVA SİSTEMLERİ VE KABLO MERDİVEN SİSTEMLERİ"

\* KABLO TAVA VE ELEMANLARI  
 GKT-XX ,GKT-X-XX Model, NORMAL HİZMET-AĞIR HİZMET-C SINIFI,DELİKLİ,METAL,ALEV YAYMAYAN-20°C/  
 +120°C,KOROZYONA KARŞI DAYANIKLILIK SINIFI 5 Genişlik: 50 mm' den - 600 mm' ye kadar, Yükseklik: 40 mm'  
 den - 100 mm' ye kadar Kalınlık: 1 , 00 mm den - 2 , 00 mm ye kadar

\* KABLO MERDİVENİ VE ELEMANLARI  
 GMI-X-XX Model, AĞIR HİZMET-Y SINIFI,DELİKLİ,METAL,ALEV YAYMAYAN-20°C/+120°C,KOROZYONA KARŞI  
 DAYANIKLILIK SINIFI 5 Genişlik: 100 mm' den - 600 mm' ye kadar, Yükseklik: 50 mm' den - 100 mm' ye kadar  
 Kalınlık: 1,5 mm den - 2 mm ye kadar



16./04/2013  
  
 A.CELAL ŞİŞİROĞLU  
 TSE İSTANBUL ÜRÜN  
 BELGELENDİRME MÜDÜRÜ

\*Enstitümüzce verilmekte olan "İmalata Yeterlilik Belgesi" 15.04.2007 tarihinden itibaren uygulamadan kaldırılmıştır.  
 \*Bu belge, belgelendirilen ürünün, üretim yerinin Enstitümüzün belirlediği şartları karşıladığını da gösterir.

TSE Kalite Kampüsü İSTANBUL\* İstanbul ÜBMCAYIROVA TREN İSTASYONU YANI BAYRAMOĞLU -GEBZE / KOCAELİ \* Tel: 0262 653 07 52-20 HAT\* Faks: 0262 653 06 49 \* web: www.kampus.tse.org.tr \* e-mail: e-mail:ubm@kampus.tse.org.tr

Bu belge hiç bir suretle tahrif edilemez, kısmen veya okunmasını zorlaştıracak şekilde çoğaltılamaz, kopyalı ve silinir yapılamaz.





**TÜRK STANDARDLARI ENSTİTÜSÜ**  
**TÜRK STANDARDLARINA UYGUNLUK BELGESİ**  
**TURKISH STANDARDS INSTITUTION**  
**CERTIFICATE OF CONFORMITY TO TURKISH STANDARDS**

Markanın Tanımı Description of the Mark  
 TSE veya/or  veya/or T S E

<b>BELGE NUMARASI</b> REFERENCE NUMBER OF LICENCE	14.0.30.4.34.00/TSE-64435
<b>BELGENİN İLK VERİLİŞ TARİHİ</b> DATE OF FIRST ISSUE OF LICENCE	16.04.2013
<b>BELGENİN SON GEÇERLİLİK TARİHİ</b> LICENCE VALID UNTIL	16.04.2014
<b>BELGE SAHİBİ KURULUŞUN ADI</b> NAME OF THE LICENCE HOLDER	GERSAN ELEKTRİK TİCARET VE SANAYİ A.Ş.
<b>BELGE SAHİBİ KURULUŞUN ADRESİ</b> ADDRESS OF THE LICENCE HOLDER	TUZLA MERMERCİLER ORGANİZE SAN. BÖL. GAZİ BULVARI NO:37-39-41 TUZLA İSTANBUL
<b>ÜRETİM YERİ ADI</b> NAME OF THE MANUFACTURING PLACE	GERSAN ELEKTRİK TİC. VE SAN. A.Ş.
<b>ÜRETİM YERİ ADRESİ</b> ADDRESS OF THE MANUFACTURING PLACE	ORG.SAN.BÖLG.1 NOLU OSB.MEYDANI 1.CADDE 6. VE 7. SOK. ÇAYCUMA/ ZONGULDAK
<b>İPTAL EDİLEN BELGE NUMARASI (Varsa)</b> INDICATION OF SUPERSEDED LICENCE (if any)	
<b>TESCİLLİ TİCARİ MARKASI</b> REGISTERED TRADE MARK	GERSAN
<b>İLGİLİ TÜRK STANDARDI</b> RELATED TURKISH STANDARD	TS EN 61537 / Kablolar -Kablo tesisi için - Kablo tava sistemleri ve kablo merdiven sistemleri / 26.06.2007
<b>BELGE KAPSAMI</b> SCOPE OF LICENCE	

TS EN 61537 JUNE/2007 "CABLE MANAGEMENT – CABLE TRAY SYSTEMS AND CABLE LADDER SYSTEMS" CABLE TRAY AND ELEMENTS  
 • GKT-XX, GKT-X-XX Model, NORMAL DUTY – HEAVY DUTY – C CLASS, PERFORATED, METAL, EXTINGUISHER – 20 ° C / + 120 ° C, CORROSION RESISTANCE CLASS:5, Width: 50mm to 600mm, Height :40mm to 100mm, Depth :1,00mm to 2,00mm.  
 CABLE LADDER AND ELEMENTS  
 • GMI-X-XX Model, HEAVY DUTY – Y CLASS, PERFORATED, METAL, EXTINGUISHER – 20 ° C / + 120 ° C, CORROSION RESISTANCE CLASS:5, Width: 100mm to 600mm, Height: 50mm to 100mm, Depth:1,50mm to 2,00mm.



16.04/2013  
  
 A.CELAL AŞKAROĞLU

MANAGER OF THE TSE ISTANBUL  
 PRODUCT CERTIFICATION DEPT.

\*Enstitümüzce verilmekte olan "İmalata Yeterlilik Belgesi" 15.04.2007 tarihinden itibaren uygulamadan kaldırılmıştır.  
 \*Bu belge, belgelendirilen ürünün, üretim yerinin Enstitümüzün belirlediği şartları karşıladığını da gösterir.

TSE Kalite Kampüsü İSTANBUL\* İstanbul ÜBMCAYIROVA TREN İSTASYONU YANI BAYRAMOĞLU -GEBZE / KOCAELİ \* Tel: 0262 653 07 52-20 HAT\* Faks: 0262 653 06 49 \* web: www.kampus.tse.org.tr \* e-mail: e-mail:ubm@kampus.tse.org.tr

Bu belge hiç bir suretle tahrif edilemez, kısmen veya tamamen zorlaştıracak şekilde çoğaltılamaz, kopyası ve silinmesi yapılamaz.

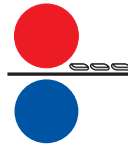

**TÜRK STANDARDLARI ENSTİTÜSÜ**  
**TÜRK STANDARDLARINA UYGUNLUK BELGESİ**  
**TURKISH STANDARDS INSTITUTION**  
**CERTIFICATE OF CONFORMITY TO TURKISH STANDARDS**

Markanın Tanımı Description of the Mark  
**TSE** veya/or  veya/or **T S E**

<b>BELGE NUMARASI</b> REFERENCE NUMBER OF LICENCE	14.11.34/TSE-63786
<b>BELGENİN İLK VERİLİŞ TARİHİ</b> DATE OF FIRST ISSUE OF LICENCE	24.06.2004
<b>BELGENİN SON GEÇERLİLİK TARİHİ</b> LICENCE VALID UNTIL	21.06.2014
<b>BELGE SAHİBİ KURULUŞUN ADI</b> NAME OF THE LICENCE HOLDER	GERSAN ELEKTRİK TİCARET VE SANAYİ A.Ş.
<b>BELGE SAHİBİ KURULUŞUN ADRESİ</b> ADDRESS OF THE LICENCE HOLDER	TUZLA MERMERCİLER ORGANİZE SANAYİ BÖLGESİ GAZİ BULVARI NO:37-39-41 PK.57 34953 TUZLA İSTANBUL/TÜRKİYE
<b>ÜRETİM YERİ ADI</b> NAME OF THE MANUFACTURING PLACE	GERSAN ELEKTRİK TİC. VE SAN. A.Ş.
<b>ÜRETİM YERİ ADRESİ</b> ADDRESS OF THE MANUFACTURING PLACE	ORGANİZE SANAYİ BÖLGESİ 1 NOLU OSB MEYDANI 1. CADDE 6 VE 7. SOKAK ÇAYCUMA/ ZONGULDAK/TÜRKİYE
<b>İPTAL EDİLEN BELGE NUMARASI (Varsa)</b> INDICATION OF SUPERSEDED LICENCE (if any)	14.11.34/TSE-7156-1
<b>TESCİLLİ TİCARİ MARKASI</b> REGISTERED TRADE MARK	ŞEKİL+GERSAN
<b>İLGİLİ TÜRK STANDARDI</b> RELATED TURKISH STANDARD	TS EN ISO 1461 / Demir ve çelikten imal edilmiş malzemeler üzerine sıcak daldırma ile yapılan galvaniz kaplamalar - Özellikler ve deney metotları / 14.07.2011
<b>BELGE KAPSAMI</b> SCOPE OF LICENCE	

TS EN ISO 1461/TEMMUZ 2011 "DEMİR VE ÇELİKTE İMAL EDİLMİŞ MALZEMELER ÜZERİNE SICAK  
DALDIRMAYLA YAPILAN GALVANİZ KAPLAMALAR-ÖZELLİKLER VE DENEY METOTLARI"  
\* SICAK DALDIRMA YÖNTEMİ İLE GALVANİZ KAPLAMA-DEMİR VE ÇELİKTE YAPILMIŞ MALZEMELER İÇİN



26/06/2013  

HAKAN DENİZ

TSE İSTANBUL BELGELENDİRME  
MÜDÜRÜ

"Enstitümüzce verilmiş olan "İmalata Yeterlilik Belgesi" 15.04.2007 tarihinden itibaren uygulamadan kaldırılmıştır.  
"Bu belge, belgelendirilen ürünün, üretim yerinin Enstitümüzün belirlediği şartları karşıladığını da gösterir.

İSTANBUL \* İSTANBUL BELGELENDİRME MÜDÜRLÜĞÜ Çayirova Tren İstasyonu Yanı ÇAYIROVAĞEBZE \* Tel: 2627231273\* Faks: 2627231606 \* web: \* e-mail:

Bu belge bir kez ücret tahsil edilmiştir, kâğıt veya elektronik ortamda değiştirilemez, kâğıt ve e-ortamda geçerlidir.

1 / 1





**TÜRK STANDARDLARI ENSTİTÜSÜ**  
**TÜRK STANDARDLARINA UYGUNLUK BELGESİ**  
**TURKISH STANDARDS INSTITUTION**  
**CERTIFICATE OF CONFORMITY TO TURKISH STANDARDS**

Markanın Tanımı Description of the Mark

**TSE** veya/or  veya/or **T S E**

<b>BELGE NUMARASI</b> <i>REFERENCE NUMBER OF LICENCE</i>	14.11.34/TSE-63786
<b>BELGENİN İLK VERİLİŞ TARİHİ</b> <i>DATE OF FIRST ISSUE OF LICENCE</i>	24.06.2004
<b>BELGENİN SON GEÇERLİLİK TARİHİ</b> <i>LICENCE VALID UNTIL</i>	21.06.2014
<b>BELGE SAHİBİ KURULUŞUN ADI</b> <i>NAME OF THE LICENCE HOLDER</i>	GERSAN ELEKTRİK TİCARET VE SANAYİ A.Ş.
<b>BELGE SAHİBİ KURULUŞUN ADRESİ</b> <i>ADDRESS OF THE LICENCE HOLDER</i>	TUZLA MERMERCİLER ORGANİZE SANAYİ BÖLGESİ GAZİ BULVARI NO:37-39-41 PK.57 34953 TUZLA İSTANBUL/TÜRKİYE
<b>ÜRETİM YERİ ADI</b> <i>NAME OF THE MANUFACTURING PLACE</i>	GERSAN ELEKTRİK TİC. VE SAN. A.Ş.
<b>ÜRETİM YERİ ADRESİ</b> <i>ADDRESS OF THE MANUFACTURING PLACE</i>	ORGANİZE SANAYİ BÖLGESİ 1 NOLU OSB MEYDANI 1. CADDE 6 VE 7. SOKAK ÇAYCUMA/ ZONGULDAK/TÜRKİYE
<b>İPTAL EDİLEN BELGE NUMARASI (Varsa)</b> <i>INDICATION OF SUPERSEDED LICENCE (if any)</i>	14.11.34/TSE-7156-1
<b>TESCİLLİ TİCARİ MARKASI</b> <i>REGISTERED TRADE MARK</i>	ŞEKİL+GERSAN
<b>İLGİLİ TÜRK STANDARDI</b> <i>RELATED TURKISH STANDARD</i>	TS EN ISO 1461 / Hot dip galvanized coatings on fabricated iron and steel articles - specification and test methods / 14.07.2011
<b>BELGE KAPSAMI</b> <i>SCOPE OF LICENCE</i>	

TS EN ISO 1461/JULY 2011 "HOT DIP GALVANIZED COATINGS ON FABRICATED IRON AND STEEL AND  
ARTICLES SPECIFICATIONS AND TEST METHODS"  
\* HOT DIP GALVANIZED COATINGS ON FABRICATED IRON AND STEEL AND ARTICLES SPECIFICATIONS  
AND TEST METHODS



26/06/2013  

HAKAN DENİZ

MANAGER OF THE TSE ISTANBUL  
CERTIFICATION DEPT.

\*Enstitümüzde verilmekte olan "İmalata Yeterlilik Belgesi" 15.04.2007 tarihinden itibaren uygulamadan kaldırılmıştır.

\*Bu belge, belgelendirilen ürünün, üretim yerinin Enstitümüzün belirlediği şartları karşıladığını da gösterir.

İSTANBUL\* İSTANBUL BELGELENDİRME MÜDÜRLÜĞÜ Çayyova Tren İstasyonu Yarı ÇAYIROVA/GEBZE \* Tel: 2627231273\* Faks: 2627231606 \* web: \* e-mail:

Bu belge hiç bir şekilde tabii edilemez, kopye veya diğer amaçla çoğaltılmayacak şekilde çoğaltılmamaz, kısıtlı ya sınırlı yapılamaz.

1 / 1



**Intertek ETL SEMKO**

## Certificate of Compliance

Item Tested: Medium Duty Cable Tray

Type: GKT-A7.5 (75mm wide, 1.0mm thick, 25mm deep)  
GKT-A10 (100mm wide, 1.0mm thick, 25mm deep)  
GKT-A15 (150mm wide, 1.0mm thick, 25mm deep)  
GKT-A22.5 (225mm wide, 1.0mm thick, 25mm deep)  
GKT-A30 (300mm wide, 1.0mm thick, 25mm deep)

No. of Samples Tested: 3 samples of each size

Relevant Specification used as Basis of Tests: BSEN 61537:2002 / IEC 61537:2001

This is to certify that, on the basis of the tests undertaken, the samples of the above items are considered to meet the requirements of the above Standards.

Signed: *N.A. Jones*  
N A Jones  
Certifying Officer

Date of test: 2 February 2006  
Date of issue: 2 February 2006

Gersan Elektrik Tic Ve San A.S.  
Tem Yan Yol Cad  
No.6 P.K.57  
Istanbul  
Turkey

Serial No: 05 5121  
Report No: 05018619A/Issue 2

Intertek Testing & Certification Ltd  
Middle House, Crown Road, Leamington, Surrey KT22 7JH  
Telephone: +44 (0)1372 370900 Fax: +44 (0)1273 370999 Email: www.uk.intertek-ett.com  
Registered No: 072091 Registered Office: 25 Searle Row, London W1S 2SS  
\*By Terms & Conditions please see website

**Intertek ETL SEMKO**

## Certificate of Compliance

Item Tested: Medium Duty Cable Tray

Type: GKT-A7.5 (75mm wide, 1.0mm thick, 25mm deep)  
GKT-A10 (100mm wide, 1.0mm thick, 25mm deep)  
GKT-A15 (150mm wide, 1.0mm thick, 25mm deep)  
GKT-A22.5 (225mm wide, 1.0mm thick, 25mm deep)  
GKT-A30 (300mm wide, 1.0mm thick, 25mm deep)

No. of Samples Tested: 3 samples of each size

Relevant Specification used as Basis of Tests: BSEN 61537:2002 / IEC 61537:2001

This is to certify that, on the basis of the tests undertaken, the samples of the above items are considered to meet the requirements of the above Standards.

Signed: *N.A. Jones*  
N A Jones  
Certifying Officer

Date of test: 2 February 2006  
Date of issue: 2 February 2006

Gersan Elektrik Tic Ve San A.S.  
Tem Yan Yol Cad  
No.6 P.K.57  
Istanbul  
Turkey

Serial No: 05 5121  
Report No: 05018619A/Issue 2

Intertek Testing & Certification Ltd  
Middle House, Crown Road, Leamington, Surrey KT22 7JH  
Telephone: +44 (0)1372 370900 Fax: +44 (0)1273 370999 Email: www.uk.intertek-ett.com  
Registered No: 072091 Registered Office: 25 Searle Row, London W1S 2SS  
\*By Terms & Conditions please see website

**Intertek ETL SEMKO**

## Certificate of Compliance

Item Tested: Cable Ladder System

Type: GMI-GNA10, GMI-GNA30, GMI-GNA60

No. of Samples Tested: 3 samples of each size

Relevant Specification used as Basis of Tests: BSEN 61537:2002 / IEC 61537:2001

This is to certify that, on the basis of the tests undertaken, the samples of the above items are considered to meet the requirements of the above Standards.

Signed: *N.A. Jones*  
N A Jones  
Certifying Officer

Date of test: 31 August 2006  
Date of issue: 31 August 2006

Gersan Elektrik Tic Ve San A.S.  
Tem Yan Yol Cad  
No.6 P.K.57  
Istanbul  
Turkey

Serial No: 065352  
Report No: 06020329

Intertek Testing & Certification Ltd  
Middle House, Crown Road, Leamington, Surrey KT22 7JH  
Telephone: +44 (0)1372 370900 Fax: +44 (0)1273 370999 Email: www.uk.intertek-ett.com  
Registered No: 072091 Registered Office: 25 Searle Row, London W1S 2SS  
\*By Terms & Conditions please see website



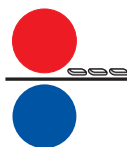

**СИСТЕМА СЕРТИФИКАЦИИ ГОСТ Р**  
**ФЕДЕРАЛЬНОЕ АГЕНТСТВО ПО ТЕХНИЧЕСКОМУ РЕГУЛИРОВАНИЮ И МЕТРОЛОГИИ**



**СЕРТИФИКАТ СООТВЕТСТВИЯ**

№ РОСС TR.AB68.H03352

Срок действия с 27.09.2010 по 26.09.2013

№ **0089400**

**ОРГАН ПО СЕРТИФИКАЦИИ** рег. № РОСС RU.0001.11AB68.  
ООО "ПРОММАШ ТЕСТ". Вокзальная пл., д. 2, г. Мытищи, Мытишинский район, Московская область,  
141009, тел. +7(495)782-17-08/775-48-45.

**ПРОДУКЦИЯ**

Системы из листовой стали для поддержки кабелей т.м. "GERSAN" (см. приложение на 2-х листах, бланки №№ 0129105, 0129106).  
Серийный выпуск.

код ОК 005 (ОКП):

34 4961

**СООТВЕТСТВУЕТ ТРЕБОВАНИЯМ НОРМАТИВНЫХ ДОКУМЕНТОВ**  
ГОСТ 20803-81

код ТН ВЭД России:

7308 90 990 0

**ИЗГОТОВИТЕЛЬ** "GERSAN ELEKTRIK TICARET VE SANAYI A.S."

Адрес: Tuzla Mermenciler San.Bolgesi.Gazi Bulvari No.37 -39-41 PK. 57 Tuzla ISTANBUL, Турция.  
Телефон (+90 216 )593 00 50, факс (+90 216)593 00 60.

**СЕРТИФИКАТ ВЫДАН** "GERSAN ELEKTRIK TICARET VE SANAYI A.S."

Адрес: Tuzla Mermenciler San.Bolgesi.Gazi Bulvari No.37 -39-41 PK. 57 Tuzla ISTANBUL, Турция.  
Телефон (+90 216 )593 00 50, факс (+90 216)593 00 60.

**НА ОСНОВАНИИ** протокола сертификационных испытаний № 4761 от 24.09.2010 г. ООО  
"АКАДЕМСИБ", рег. № РОСС RU.0001.21AB09, адрес: РФ, 630024, г. Новосибирск, ул. Бетонная, 14

**ДОПОЛНИТЕЛЬНАЯ ИНФОРМАЦИЯ** Сертификат системы менеджмента качества ISO 9001:2000  
№ IS1368189 от 24.03.2010, выданный ОС "LRQA".

Схема сертификации: 3.



Руководитель органа

*(Signature)*  
подпись

А.А. Румянцев

инициалы, фамилия

Эксперт

А.В. Прянин

инициалы, фамилия

Сертификат не применяется при обязательной сертификации



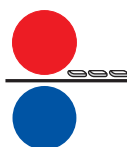

**СИСТЕМА СЕРТИФИКАЦИИ ГОСТ Р**  
**ФЕДЕРАЛЬНОЕ АГЕНТСТВО ПО ТЕХНИЧЕСКОМУ РЕГУЛИРОВАНИЮ И МЕТРОЛОГИИ**

№ **0129105**

**ПРИЛОЖЕНИЕ**

К сертификату соответствия № РОСС TR.AB68.H03352

**Перечень конкретной продукции, на которую распространяется действие сертификата соответствия**

код ОК 005 (ОКП)	Наименование и обозначение продукции, ее изготовитель	Обозначение документации, по которой выпускается продукция
код ТН ВЭД России		
34 4961 7308 90 990 0	Системы из листовой стали для поддержки кабелей т.м. "GERSAN":  Кабельные лотки металлические горячей и предварительной оцинковки с перфорацией и без перфорации с комплектующими, типов: GKT, GKKT, GD, GT, GDB, GIB, GKT-A, GKKT-A, GD-A, GT-A, GDB-A, GIB-A, GKT-B, GKKT-B, GD-B, GT-B, GDB-B, GIB-B, GKT-C, GKKT-C, GD-C, GT-C, GDB-C, GIB-C, GSR, GR, DTK-A, DTK-B, DTK-C, GGE, GATK, GTAP, GGKT, GGKKT, GGKT-A, GGKKT-A, GGKT-B, GGKKT-B, GGD, GGT, GGDB, GGIB, GTKK, GDTKK, GTTKK, GTDB, GТIB, GTEB, GTSE, GTEP, GTGR, GKT-K, GKK, GH, GES, G-SON, GSAP, GYD, GYD-M  Кабельные лотки лестничного типа металлические горячей и предварительной оцинковки с перфорацией и без перфорации с комплектующими, типов: GMI, GMID, GMT, GMIDB, GMII, GMS, GN, GNA, GNB, GNC, GNE, MTE, GND, GNT, GNDB, GNIC, GCM, GCMD, GCMT, GCMDB, GCMID, GCMIC, GMIE, GMJET, GMIEDB, GM, GMD, GMT, GMDB, GMI, GSR, GR, KKA  Кабельные лотки проволочные металлические горячей и предварительной оцинковки с комплектующими, типов: TTK, TTK-A, TTK-B, TTK-C, TTK-MP, TTK-P, TTK-LP, TTK-L  Опорные элементы металлические горячей и предварительной оцинковки с перфорацией и без перфорации с комплектующими, типов: G9, G10, G1, GP, GK, GI-HP, GDP, TK, G7, G8, GT-HP, G-40x40x4, G-50x50x5, G-NPU-65, GASK,	



Руководитель органа

*[Handwritten signature]*  
подпись

А.А. Румянцев  
инициалы, фамилия

Эксперт

А.В. Прянин  
инициалы, фамилия

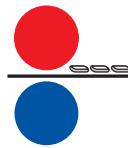

**СИСТЕМА СЕРТИФИКАЦИИ ГОСТ Р**  
**ФЕДЕРАЛЬНОЕ АГЕНТСТВО ПО ТЕХНИЧЕСКОМУ РЕГУЛИРОВАНИЮ И МЕТРОЛОГИИ**

№ **0129106**

**ПРИЛОЖЕНИЕ**

К сертификату соответствия № РОСС TR.AB68.H03352

**Перечень конкретной продукции, на которую распространяется  
действие сертификата соответствия**

код ОК 005 (ОКП) код ТН ВЭД России	Наименование и обозначение продукции, ее изготовитель	Обозначение документации, по которой выпускается продукция
34 4961 7308 90 990 0	<p>G9-P, G9-L, G9-DP, G-11, G-12, G-13, G-14, G-15, G-16, G-17, G-18, G-19, G-5, GKA, GKD, G-2, G-3, G-4, GART, GHK, G730, G740, G750, G760, G810, G820, G830, G840, G850, G860, GTAK, GTAK-Z, GER, GTT, GUT, GKP, GAT, GDTK, GPÇ, GPP, GBT, GBD, GBE, GB, BK, GBC, GBY, GDTO, GDTO-B, GDTO-C, GDTD, GDTD-B, GDTD-C, GRT, GKM, GI, GIC, GU, GBK, GC, GP, GCC, GKC, GCP, BP</p> <p>Кабельные лотки из нержавеющей стали с перфорацией и без перфорации с комплектующими, типов: GKT P, GKKT P, G1 P, GD P, GT P, GDB P, GIB P, GKT-A P, GD-A P, GT-A P, GDB-A P, GIB-A P, GKT-B P, GKKT-B P, GD-B P, GT-B P, GDB-B P, GIB-D P, GKT-C P, GKKT-C P, GD-C P, GT-C P, GDB-C P, GIB-C P, GMI P, GMID P, GMIT P, GMIDB P, GMII P, GMS P, GES P, GKK P, TTK-P, TTK-A P, TTK-B P, TTK-C P, TTK-MP P, TTK-P P, TTK-LP P, TTK-L P</p> <p>Кабельные лотки из алюминия с перфорацией и без перфорации с комплектующими, типов: GNM AL, GNM-B AL, GNM-C AL, G1 AL, GKT AL, GES AL, GKK AL, GNMD AL, GNMT AL, GNMDB AL, GNMIC AL, GNMID AL, GNMD AL, GKT-K AL</p>	
	<p>ИЗГОТОВИТЕЛЬ: "GERSAN ELEKTRİK TICARET VE SANAYİ A.Ş." Tuzla Mermerciler San.Bolgesi.Gazi Bulvari No.37 -39-41 PK. 57 Tuzla ISTANBUL, Турция</p>	



Руководитель органа

*(Signature)*  
ПОДПИСЬ

А.А. Румянцев

инициалы, фамилия

Эксперт

ПОДПИСЬ

А.В. Прянин

инициалы, фамилия





**СИСТЕМА СЕРТИФИКАЦИИ ГОСТ Р**  
ФЕДЕРАЛЬНОЕ АГЕНТСТВО ПО ТЕХНИЧЕСКОМУ РЕГУЛИРОВАНИЮ И МЕТРОЛОГИИ

**СЕРТИФИКАТ СООТВЕТСТВИЯ**

№ РОСС ТРА.В68.В03363  
Срок действия с 11.02.2010 по 10.02.2013  
№ 0170226

**ОРГАН ПО СЕРТИФИКАЦИИ** рег. № РОСС RU.0001.11АВ68,  
ООО "ПРОММАШ ТЕСТ", Вольский пл., д. 2, г. Мытищи, Мытищинский район, Московская область,  
141009, тел. +7(495)782-17-68/773-41-45.

**ПРОДУКЦИЯ**  
Крепежные изделия т.м. "GERSAN" (см. приложение на 1-ом листе, бланк № 0129110).  
Серийный выпуск: 16 0000

**СООТВЕТСТВУЕТ ТРЕБОВАНИЯМ НОРМАТИВНЫХ ДОКУМЕНТОВ**  
ГОСТ 1759.0 (и.п. 2.1, 2.2); ГОСТ 18123-82 (и.п.1.6, 1.8, 1.10);  
ГОСТ 6402-70 (и.п. 2.3, 2.10, 2.11)

**ИЗГОТОВИТЕЛЬ** "GERSAN ELEKTRİK TİCARİET VE SANAYİ A.Ş."  
Адрес: Tuza Memeciler San.Bölgesi Gazı Bulvarı No.37 -39-41 PK. 57 Tuza İSTANBUL, Турция. Телефон  
(+90 216 3593 00 30, факс (+90 216)593 00 00.

**СЕРТИФИКАТ ВЫДАН** "GERSAN ELEKTRİK TİCARİET VE SANAYİ A.Ş."  
Адрес: Tuza Memeciler San.Bölgesi Gazı Bulvarı No.37 -39-41 PK. 57 Tuza İSTANBUL, Турция. Телефон  
(+90 216 3593 00 30, факс (+90 216)593 00 00.

**НА ОСНОВАНИИ** протокола сертификационных испытаний №№ 2330-261, 2231-261 от 11.02.2010г.  
ИД машиностроения "РОСТЕСТ-МОСКВА", рег. № РОСС RU.0001.21МВ09 от 26.12.2007, адрес: 117418, г.  
Москва, Нахимовский проспект, д. 31

**ДОПОЛНИТЕЛЬНАЯ ИНФОРМАЦИЯ** Сертификат системы менеджмента качества ISO 9001:2000  
№ 58419 от 01.01.2009, выданный ОС "ЛЮДА". Место нанесения знака соответствия: знак соответствия по  
ГОСТ Р 50460-92 наносится на корпус изделия и (или) в эксплуатационную документацию.  
См. сертификат №...

Руководитель органа: А.А. Румянцева  
Эксперт: В.Н. Барышников

**СИСТЕМА СЕРТИФИКАЦИИ ГОСТ Р**  
ФЕДЕРАЛЬНОЕ АГЕНТСТВО ПО ТЕХНИЧЕСКОМУ РЕГУЛИРОВАНИЮ И МЕТРОЛОГИИ

№ 0129110

**ПРИЛОЖЕНИЕ**  
К сертификату соответствия № РОСС ТРА.В68.В03363

Перечень конкретной продукции, на которую распространяется  
действие сертификата соответствия

код ОК 005/ОКП	Наименование и обозначение продукции, ее изготовитель	Обозначение документации, по которой выпускается продукция
код ТН ВЭД России		
16 8000 7318 00 000 0	Крепежные изделия т.м. "GERSAN"	
16 8000 7318 16 910 0	Гайки для «С» шпильки профиля М6, М8, М10, М12, тип. GCSA, GCSB	
16 8000 7318 15 900 0	Валты для «С» шпильки профиля М6, М8, М10, М12, тип. GCSA, GCSB, GCSX, GCSY, GCSZ Валты М6, М8, М10, тип. (DIN 934 А)	
16 1000 7318 15 000 0	Валты М6, М8, М10 для кабельного крепления Валты М6, М8, М10 тип. (DIN 931) Валты М6Х13 тип. GB	
16 8000 7318 15 000 0	Валты для кабельного крепления М6, М8, М10 Шпилька КК80, тип. GB	
16 8000 7318 15 000 0	Шпилька М6, М8, М10, М12, тип. GAT Гайка (DIN 6334) М6, М8, М10, М12, тип. GB Гайка (DIN 934) М6, М8, М10, М12, тип. GB	
16 8000 7318 22 000 0	Гайка (DIN 125-1A) М6, М8, М10, М12, тип. GB Шайбы пружинные (DIN 1770) М6, М8, М10, М12, тип. GB	
16 8000 7318 00 000 0	Шайбы гребенчатые (DIN 1270) М6, М8, М10, М12, тип. GB	
16 3000 7318 15 000 0	Анкерные болты усиленные М6, М8, М10, М12, тип. GB Анкерные болты М6, М8, М10, М12, тип. GB	
	ИЗГОТОВИТЕЛЬ: "GERSAN ELEKTRİK TİCARİET VE SANAYİ A.Ş." Tuza Memeciler San.Bölgesi Gazı Bulvarı No.37 -39-41 PK. 57 Tuza İSTANBUL, Турция	

Руководитель органа: А.А. Румянцева  
Эксперт: В.Н. Барышников

**РОССИЙСКАЯ ФЕДЕРАЦИЯ**  
**ДЕКЛАРАЦИЯ О СООТВЕТСТВИИ**  
№ Д-ТР.АГ85.В.06497  
(обязательная декларация о соответствии)

**ЗАЯВИТЕЛЬ** ЗАО «ГЕРСАН-Р»  
236008, г. Калининград, ул. Ленинградская, д. 4. ОГРН: 1097847210251 от 11.08.2009 г.,  
выдан Межрайонной инспекцией Федеральной налоговой службы № 15 по Санкт-Петербургу. Телефон: (49150)66-338

**ИЗГОТОВИТЕЛЬ** "GERSAN ELEKTRİK TİCARİET VE SANAYİ A.Ş.", Турция  
Tuza Memeciler San.Bölgesi Gazı Bulvarı No. 37-39-41 PK. 57 Tuza İSTANBUL, Turkey

**ЗАЯВИТЕЛЬ ПОДТВЕРЖДАЕТ,**  
**ЧТО ПРОДУКЦИЯ** Изделия крепежные т.м. "GERSAN" по приложению.  
Контракт № 1 GR от 11.02.2013 г.  
Серийный выпуск  
(информация об объекте декларирования отсутствует, подлежащая сертификации, объект)

код ОК 005/ОКП: 16 1000, 16 3000, 16 5000, 16 8000  
код ТН ВЭД России: 7318 00 000 0

**СООТВЕТСТВУЕТ ТРЕБОВАНИЯМ**  
**ТЕХНИЧЕСКОГО РЕГЛАМЕНТА (ТЕХНИЧЕСКИХ РЕГЛАМЕНТОВ)**  
Технический регламент "О безопасности машин и оборудования" (Постановление  
Правительства РФ от 15.09.2009г. N 753), с изменениями, принятыми постановлением  
Правительства РФ от 24.03.2011 № 205

**СХЕМА ДЕКЛАРИРОВАНИЯ СООТВЕТСТВИЯ** 2з  
**ПРОВЕДЕННЫЕ ИССЛЕДОВАНИЯ (ИСПЫТАНИИ) И ИЗМЕРЕНИЯ, СЕРТИФИКАТ**  
**СИСТЕМЫ КАЧЕСТВА, ДОКУМЕНТЫ, ПОСЛУЖИВШИЕ ОСНОВАНИЕМ ДЛЯ**  
**ПОДТВЕРЖДЕНИЯ СООТВЕТСТВИЯ**  
Протоколы испытаний №№ 445-038-02/13, 447-038-02/13 от 14.02.2013 г. ИЦ АНО  
"Манитест", рег. № РОСС RU.0001.21АВ054

**ИНЫЕ СВЕДЕНИЯ**  
(сведения, предусмотренные техническим регламентом (обязательным регламентом))

**ЗАЯВЛЕНИЕ ЗАЯВИТЕЛЯ:** продукция безопасна при ее использовании в соответствии с  
целями назначения. Заявителем приняты меры по обеспечению соответствия  
продукции требованиям технического регламента

**СРОК ДЕЙСТВИЯ ДЕКЛАРАЦИИ О СООТВЕТСТВИИ** с 14.02.2013 по 13.02.2018  
М.П. Заявитель: Сары Али

Декларация о соответствии зарегистрирована  
ОС ООО "Технологии и Сервис", РФ, 603105, Нижегородская область, г. Нижний  
Новгород, ул. Полянская, д. 35, корп. 2, пом. № 3 ОГРН: 1115262000303

Агтисрег рег. № РОСС RU.0001.10АГ85 выдан 05.08.2011г. Федеральным Агентством по  
Техническому Регулированию и Метрологии

М.П. Руководитель (уполномоченное им лицо)  
Ю.Ф. Фролова

**РОССИЙСКАЯ ФЕДЕРАЦИЯ**  
**ПРИЛОЖЕНИЕ № 1**  
**К ДЕКЛАРАЦИИ О СООТВЕТСТВИИ № Д-ТР.АГ85.В.06497**  
(обязательная сертификация)

**Перечень продукции:**  
Изделия крепежные т.м. "GERSAN"

Код ОКП Код ТН ВЭД	Наименование и обозначение продукции, ее изготовитель
16 8000 7318 16 910 9	- гайки
16 5000 7318 15 900 9	- валты
16 1000 7318 15 700 9	- болты
16 6000 7318 19 000 9	- шпильки
16 8000 7318 22 000 9	- шайбы пружинные, шайбы гребенчатые
16 3000 7318 15 300 9	- болты анкерные
16 8000 7318 15 810 0	- гайки, шайбы (комплект)

И.о. генерального директора  
ЗАО «ГЕРСАН-Р» Сары Али

М.П. Руководитель (уполномоченное им лицо)  
органа, регистрирующего декларацию о  
соответствии Ю.Ф. Фролова



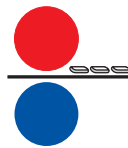

**СИСТЕМА ДОБРОВОЛЬНОЙ СЕРТИФИКАЦИИ В ОБЛАСТИ ПОЖАРНОЙ БЕЗОПАСНОСТИ**  
**регистрационный № РОСС RU.M704.04ЮАБ0**

**СЕРТИФИКАТ СООТВЕТСТВИЯ**

№ НСОПБ.ТР.ПР.135/2.Н.00074  
*(номер сертификата соответствия)*

011731  
*(учетный номер бланка)*

**ЗАЯВИТЕЛЬ**  
*(наименование и местонахождение заявителя)*

ЗАО "ГЕРСАН-Р", ОГРН 1097847210251  
236008 г. Калининград ул. Ленинградская, д.4 Россия, тел. +7 (4012) 310302

**ИЗГОТОВИТЕЛЬ**  
*(наименование и местонахождение изготовителя продукции)*

"GERSAN ELEKTRIK TICARET VE SANAY A.S."  
Tuzla Mermerciler San.Bolgesi.Gazi Buivari No. 37-39-41 PK.57 Tuzla  
INSTAMBUL, Турция, тел. 902165930050

**ОРГАН ПО СЕРТИФИКАЦИИ**  
*(наименование и местонахождение органа по сертификации, выдавшего сертификат соответствия)*

Орган по сертификации Общество с ограниченной ответственностью  
"Гильдия Качества", ОГРН 1117746468399 свидетельство о подтверждении  
компетентности № НСОПБ ЮАБ0.RU.OC.ПР.135/2 от 23.12.2011 г.,  
115088, г. Москва, ул. Шарикоподшипниковская, д.4, корп.12, тел. +7(906)  
795-71-65.

**ПОДТВЕРЖДАЕТ, ЧТО ПРОДУКЦИЯ**  
*(информация о сертифицированной продукции, позволяющая провести идентификацию)*

Системы из листовой стали для поддержки кабелей  
т.м. "GERSAN".  
(См. приложения - бланки №№ 001495, 001498).  
Контракт № 1 GR от 11.02.2013г.  
Серийный выпуск

код ОК 005 (ОКП)  
**34 4990**

**СООТВЕТСТВУЕТ ТРЕБОВАНИЯМ**  
*(наименование национальных стандартов, стандартов организаций, условий договоров на соответствие требованиям которых проводится сертификация)*

ГОСТ Р 53313-2009 (п.5.4).

код ТН ВЭД России  
**7308909900**

**ПРОВЕДЕННЫЕ ИССЛЕДОВАНИЯ (ИСПЫТАНИЯ) И ИЗМЕРЕНИЯ**

Протокол испытаний № СД13-7-8/2 от 08.07.2013г. ООО "Гильдия Качества",  
свидетельство о подтверждении компетентности № НСОПБ ЮАБ0.RU.ИЛ.ПР.127/2 от 23.12.2011 г., 115088, г. Москва, ул.  
Шарикоподшипниковская, д.4, корп.12

**ПРЕДСТАВЛЕННЫЕ ДОКУМЕНТЫ**  
*(документы, представленные заявителем в орган по сертификации в качестве доказательств соответствия продукции)*

заявка-декларация № 96 от 14.06.2013г. Сертификат системы менеджмента качества ГОСТ ISO 9001-2011 № СДГК RU.OC05.K02042 от 14.06.2013 г. выдан ОС АНО «Калуга-Тест» номер аттестата аккредитации СДГК RU.3608.OC05 от 11.01.2010 г.

**СРОК ДЕЙСТВИЯ СЕРТИФИКАТА СООТВЕТСТВИЯ** с 08.07.2013 г. по 07.07.2014 г.



Руководитель  
(заместитель руководителя органа по сертификации)  
*(подпись, инициалы, фамилия)*

А.С. Хромова

Эксперт (эксперты)  
*(подпись, инициалы, фамилия)*

С.А. Сапронова



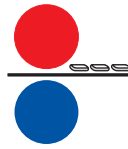

  
 ДЕРЖАВНИЙ КОМПІТЕТ УКРАЇНИ З ПИТАНЬ ТЕХНІЧНОГО РЕГУЛЮВАННЯ  
 ТА СПОЖИВЧОЇ ПОЛІТИКИ  
 ДЕРЖАВНА СИСТЕМА СЕРТИФІКАЦІЇ УкрСЕПРО

№ 184774 Серія ВВ

## СЕРТИФІКАТ ВІДПОВІДНОСТІ

Зареєстровано в Реєстрі за № UA1.081.0008847-10  
 Зареєстровано в Реєстрі

Термін дії з 11 лютого 2010 до 10 лютого 2012  
 Срок действия с

Продукція **Канали для кабелю та опорні елементи до них металеві**  
 Продукция **торговельної марки 'GERSAN'** 7308  
код УКТ ЗЕД ТН ЗЕД  
код ДКПП, ОКП

Відповідає вимогам  
 Соответствует требованиям  
**з конструкції, матеріалу, міцності, покриття, електрозахисного заземлення,  
 що встановлені в ГОСТ 12.2.007.0-75, ГОСТ 20783-81, ГОСТ 27487-87**

Виробник продукції **Фірма 'GERSAN ELEKTRIK TICARET VE SANAYI A.S.',**  
 Изготовитель продукции **Tuzla Mermerciler San. Bolgesi Gazi Bulvari No:37-39-41 PK 57 Tuzla,  
 Istanbul, Turkiye / Туреччина**

Сертифікат видано **Фірмі 'GERSAN ELEKTRIK TICARET VE SANAYI A.S.',**  
 Сертификат выдан **Tuzla Mermerciler San. Bolgesi Gazi Bulvari No:37-39-41 PK 57 Tuzla,  
 Istanbul, Turkiye / Туреччина**

Додаткова інформація  
 Дополнительная информация  
**Канали для кабелю та опорні елементи до них металеві торговельної марки 'GERSAN',  
 що випускаються серійно з 11.02.2010 до 10.02.2012. Технічний нагляд - 1 раз на рік**

Сертифікат видано органом з сертифікації  
 Сертификат выдан органом по сертификации  
**ОС 'НікоСЕПРО' ВАТ 'МЕТЦ' (реєстр. №UA.P.081, №UA.PN.081 від 24.12.2008),  
 Україна, 54055, м. Миколаїв, вул. Севастопольська, 67, тел. +38 0512 479080,  
 E-mail: nikocsm@etc.mk.ua, www.nikocepro.com**  
 На підставі **протоколу випробувань №71-10 від 09.02.2010 ВЦ 'НікоСЕПРО' ВАТ 'МЕТЦ'  
 (ат. № 2Н516 від 14.09.2009), акта обстеження виробництва №4-10 від 09.02.2010  
 ОС 'НікоСЕПРО' ВАТ 'МЕТЦ'**

Керівник органу з сертифікації **Н. Долинюк**  
 Руководитель органа по сертификации підписе ініціали, прізвище

М.П.  

Чинність сертифіката відповідності можна  
 перевірити в Реєстрі системи УкрСЕПРО  
 за тел. (044) 537-35-76

Держком. КСФ. Зам. 2790 2008 р. 0 кв.

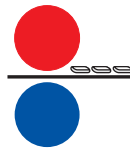

**LRQA**  
Business Assurance

**ONAY SERTİFİKASI**

Bu Kalite Yönetim Sistem Sertifikası,  
**GERSAN ELEKTRİK TİC. VE SAN. A.Ş.**  
İstanbul Anadolu Yakası Organize Sanayi Bölgesi Gazı Bulvarı  
No: 39-41 34953 Tuzla  
İSTANBUL-TÜRKİYE

firmasının Kalite Yönetim Sistemi'nin Lloyd's Register Quality Assurance Limited tarafından onaylandığının belgesidir. Bu sertifika aşağıda belirtilen kalite yönetim standartları için geçerlidir.

**ISO 9001:2008**

Kalite Yönetim Sistemi kapsamı:

**Kablo Kanalı, Merdiveni ve Aksesuarları, Döşeme Altı Kablo Kanalı, Buatı ve Aksesuarları, Topraklama Malzemeleri ve Paratoner Bağlantı Elemanları, Platform Izgaraları, Askı, Gergi Takımları, Telefon Nakil Hattı Hırdavat Malzemeleri, Busbar Kanal Üretimi ve Sıcak Daldırma Galvanizleme, Elektrik Dağıtım Panolarının İmalatı, Elektrikli Araç Şarj Sistemleri ve G-BUS Endüstriyel Otomasyon Sistemi İmalatı**

Bu sertifika, sadece onay verilen sahaların listelendiği ve üzerinde aynı sertifika onay numarasını taşıyan sertifika eki ile birlikte geçerlidir.

Sertifika Onay No : IST6005522/A İlk onay: 27 Ocak 2004  
Şimdiki sertifika: 17 Mart 2013  
Geçerlilik süresi: 16 Mart 2016

Lloyd's Register Quality Assurance Limited adına  
Lloyd's Register Gözetim Ltd.Şti. tarafından verilmiştir.

 1 / 2

This document is subject to the provision on the reverse  
71 Sandhurst Street, London EC2A 4DU United Kingdom. Registration number 1810210  
This approval is granted only in accordance with the LRQA governance and certification procedures and is limited to ISO 9001:2008  
The use of the LRQA Accreditation Mark requires identification of the scope of the activities covered by the Accreditation Certificate Number 001

**LRQA**  
Business Assurance

**ONAY SERTİFİKASI**

Lokasyon	Adres	Kapsam
<b>Merkez Ofis</b>	İstanbul Anadolu Yakası Organize Sanayi Bölgesi Gazı Bulvarı No: 39-41 34953 Tuzla İstanbul, Türkiye	Kablo Kanalı, Merdiveni ve Aksesuarları, Döşeme Altı Kablo Kanalı, Buatı ve Aksesuarları, Topraklama Malzemeleri ve Paratoner Bağlantı Elemanları, Askı, Gergi Takımları, Telefon Nakil Hattı Hırdavat Malzemeleri Üretimi, Elektrik Dağıtım Panolarının İmalatı, Elektrikli Araç Şarj Sistemleri ve G-BUS Endüstriyel Otomasyon Sistemi İmalatı
<b>Lokasyon1</b>	Çayyuma Organize Sanayi 1. Nolu OSB Meydanı 1. Cadde 6. ve 7. Sokak Çayyuma Zonguldak, Türkiye	Kablo Kanalı, Merdiveni ve Aksesuarları, Döşeme Altı Kablo Kanalı, Buatı ve aksesuarları, Topraklama Malzemeleri ve Paratoner Bağlantı Elemanları, Platform Izgaraları, Askı, Gergi Takımları, Telefon Nakil Hattı Hırdavat Malzemeleri, Busbar Kanal Üretimi ve Sıcak Daldırma Galvanizleme, Elektrik Dağıtım Panolarının İmalatı

Sertifika Onay No : IST6005522/A İlk onay: 27 Ocak 2004  
Şimdiki sertifika: 17 Mart 2013  
Geçerlilik süresi: 16 Mart 2016

 2 / 2

This document is subject to the provision on the reverse  
71 Sandhurst Street, London EC2A 4DU United Kingdom. Registration number 1810210  
This approval is granted only in accordance with the LRQA governance and certification procedures and is limited to ISO 9001:2008  
The use of the LRQA Accreditation Mark requires identification of the scope of the activities covered by the Accreditation Certificate Number 001

**LRQA**  
Business Assurance

**CERTIFICATE OF APPROVAL**

This is to certify that the Quality Management System of:  
**GERSAN ELEKTRİK TİC. VE SAN. A.Ş.**  
İstanbul Anadolu Yakası Organize Sanayi Bölgesi Gazı Bulvarı  
No: 39-41 34953 Tuzla  
İSTANBUL-TURKEY

has been approved by Lloyd's Register Quality Assurance to the following Quality Management System Standards:  
**ISO 9001:2008**

The Quality Management System is applicable to:

**Manufacture of Cable Trays, Ladders and Accessories, Under Floor Cable, Trays, Junction Boxes and Accessories, Mounting Materials, Platform Grids, Earthing Materials and Lighting Rod, Tension and Suspension Materials, Telecommunication Transmission Line Materials, Bus-Bar Duct and Hot Dip Galvanization, Manufacture of Electrical Panel Boards, Electric Vehicle Charging Station Equipment and Industrial Automation Production of G-BUS**

This certificate is valid only in association with the certificate schedule bearing the same number on which the locations applicable to this approval are listed.

Approval Certificate No: IST6005522/A Original Approval: 27 January 2004  
Current Certificate: 17 March 2013  
Certificate Expiry: 16 March 2016

Issued by: Lloyd's Register Gözetim Ltd. Şti. for and on behalf Of Lloyd's Register Quality Assurance Limited.

 Page 1/2

This document is subject to the provision on the reverse  
71 Sandhurst Street, London EC2A 4DU United Kingdom. Registration number 1810210  
This approval is granted only in accordance with the LRQA governance and certification procedures and is limited to ISO 9001:2008  
The use of the LRQA Accreditation Mark requires identification of the scope of the activities covered by the Accreditation Certificate Number 001

**LRQA**  
Business Assurance

**CERTIFICATE OF APPROVAL**

Location	Address	Scope
<b>Head Office</b>	İstanbul Anadolu Yakası Organize Sanayi Bölgesi Gazı Bulvarı No: 39-41 34953 Tuzla İstanbul, Turkey	Manufacture of Cable Trays, Ladders and Accessories, Under Floor Cable, Trays, Junction Boxes and Accessories, Earthing Materials and Lighting Rod, Mounting Materials, Tension and Suspension Materials, Telecommunication Transmission Line Materials, Manufacture of Electrical Panel Boards, Electric Vehicle Charging Station Equipment and Industrial Automation Production of G-BUS
<b>Location1</b>	Çayyuma Organize Sanayi 1. Nolu OSB Meydanı 1. Cadde 6. ve 7. Sokak Çayyuma Zonguldak, Turkey	Manufacture of Cable Trays, Ladders and Accessories, Under Floor Cable, Trays, Junction Boxes and Accessories, Mounting Materials, Platform Grids, Earthing Materials and Lighting Rod, Tension and Suspension Materials, Telecommunication Transmission Line Materials, Bus-Bar Duct and Hot Dip Galvanization, Manufacture of Electrical Panel Boards

Approval Certificate No: IST6005522/A Original Approval: 27 January 2004  
Current Certificate: 17 March 2013  
Certificate Expiry: 16 March 2016

 Page 2/2

This document is subject to the provision on the reverse  
71 Sandhurst Street, London EC2A 4DU United Kingdom. Registration number 1810210  
This approval is granted only in accordance with the LRQA governance and certification procedures and is limited to ISO 9001:2008  
The use of the LRQA Accreditation Mark requires identification of the scope of the activities covered by the Accreditation Certificate Number 001



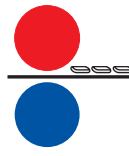

**LRQA**  
Business Assurance

**ONAY SERTİFİKASI**

Bu Çevre Yönetim Sistem Sertifikası,  
**GERSAN ELEKTRİK TİC. VE SAN. A.Ş.**  
İstanbul Anadolu Yakası Organize Sanayi Bölgesi Gazı Bulvarı  
No: 39-41 34953 Tuzla  
İSTANBUL-TÜRKİYE

firmanın Çevre Yönetim Sistemi'nin Lloyd's Register Gözetim Ltd. Şti. tarafından onaylandığının belgesidir. Bu sertifika aşağıda belirtilen çevre yönetim standartları için geçerlidir.

**ISO 14001: 2004**

Çevre Yönetim Sistemi kapsamı:

**Kablo Kanalı, Merdiveni ve Aksesuarları, Döşeme Altı Kablo Kanalı, Buatı ve Aksesuarları, Topraklama Malzemeleri ve Paratoner Bağlantı Elemanları, Platform İzgaraları, Askı, Gergi Takımları, Telefon Nakil Hattı Hırdavat Malzemeleri, Busbar Kanal Üretimi ve Sıcak Daldırma Galvanizleme, Elektrik Dağıtım Panolarının İmalatı, Elektrikli Araç Şarj Sistemleri ve G-BUS Endüstriyel Otomasyon Sistemi İmalatı**

Bu sertifika, sadece onay verilen salarının istisnasıyla ve üzerinde aynı sertifika onay numarasını taşıyan sertifika eki ile birlikte geçerlidir.

Sertifika Onay No : IST6005522/B İlk onay: 17 Mart 2010  
Şimdiki sertifika: 17 Mart 2013  
Geçerlilik süresi: 16 Mart 2016

*[Signature]*  
Lloyd's Register Quality Assurance Limited adına  
Lloyd's Register Gözetim Ltd.Şti. tarafından verilmiştir.

 1 / 2

Bu doküman ekli veya farklı kopyaları içerir.  
71 Fenchurch Street, London EC3A 4BS United Kingdom. Registration number 1879210.  
No other UKAS logo or other certification marks should be used in conjunction with this certification. For more information visit www.ukas.com

**LRQA**  
Business Assurance

**ONAY SERTİFİKASI**

<u>Lokasyon</u>	<u>Adres</u>	<u>Kapsam</u>
<u>Merkez Ofis</u>	İstanbul Anadolu Yakası Organize Sanayi Bölgesi Gazı Bulvarı No: 39-41 34953 Tuzla İstanbul, Türkiye	Kablo Kanalı, Merdiveni ve Aksesuarları, Döşeme Altı Kablo Kanalı, Buatı ve Aksesuarları, Topraklama Malzemeleri ve Paratoner Bağlantı Elemanları, Askı, Gergi Takımları, Telefon Nakil Hattı Hırdavat Malzemeleri Üretimi, Elektrik Dağıtım Panolarının İmalatı, Elektrikli Araç Şarj Sistemleri ve G-BUS Endüstriyel Otomasyon Sistemi İmalatı
<u>Lokasyon 1</u>	Çayırcıma Organize Sanayi 1. Nolu OSB Meydanı 1. Caddesi 6. ve 7. Sokak Çayırcıma Zonguldak, Türkiye	Kablo Kanalı, Merdiveni ve Aksesuarları, Döşeme Altı Kablo Kanalı, Buatı ve aksesuarları, Topraklama Malzemeleri ve Paratoner Bağlantı Elemanları, Platform İzgaraları, Askı, Gergi Takımları, Telefon Nakil Hattı Hırdavat Malzemeleri, Busbar Kanal Üretimi ve Sıcak Daldırma Galvanizleme, Elektrik Dağıtım Panolarının İmalatı

Sertifika Onay No : IST6005522/B İlk onay: 17 Mart 2010  
Şimdiki sertifika: 17 Mart 2013  
Geçerlilik süresi: 16 Mart 2016

 2 / 2

Bu doküman ekli veya farklı kopyaları içerir.  
71 Fenchurch Street, London EC3A 4BS United Kingdom. Registration number 1879210.  
No other UKAS logo or other certification marks should be used in conjunction with this certification. For more information visit www.ukas.com

**LRQA**  
Business Assurance

**CERTIFICATE OF APPROVAL**

This is to certify that the Environmental Management System of:

**GERSAN ELEKTRİK TİC. VE SAN. A.Ş.**  
İstanbul Anadolu Yakası Organize Sanayi Bölgesi Gazı Bulvarı  
No: 39-41 34953 Tuzla  
İSTANBUL-TURKEY

has been approved by Lloyd's Register Quality Assurance to the following Environmental Management System Standard:

**ISO 14001: 2004**

The Environmental Management System is applicable to:

**Manufacture of Cable Trays, Ladders and Accessories, Under Floor Cable, Trays, Junction Boxes and Accessories, Mounting Materials, Platform Grids, Earthing Materials and Lighting Rod, Tension and Suspension Materials, Telecommunication Transmission Line Materials, Bus-Bar Duct and Hot Dip Galvanization, Manufacture of Electrical Panel Boards, Electric Vehicle Charging Station Equipment and Industrial Automation Production of G-BUS**

This certificate is valid only in association with the certificate schedule bearing the same number on which the locations applicable to this approval are listed.

Approval Certificate No: IST6005522/B Original Approval: 17 March 2010  
Current Certificate: 17 March 2013  
Certificate expiry: 16 March 2016

*[Signature]*  
Issued by Lloyd's Register Gözetim Ltd.Şti. for and on behalf of Lloyd's Register Quality Assurance Limited

 Page 1/2

This document is subject to the provision on the reverse  
71 Fenchurch Street, London EC3A 4BS United Kingdom. Registration number 1879210.  
No other UKAS logo or other certification marks should be used in conjunction with this certification. For more information visit www.ukas.com

**LRQA**  
Business Assurance

**CERTIFICATE OF APPROVAL**

<u>Location</u>	<u>Address</u>	<u>Scope</u>
<u>Head Office</u>	İstanbul Anadolu Yakası Organize Sanayi Bölgesi Gazı Bulvarı No: 39-41 34953 Tuzla İstanbul, Turkey	Manufacture of Cable Trays, Ladders and Accessories, Under Floor Cable, Trays, Junction Boxes and Accessories, Earthing Materials and Lighting Rod, Mounting Materials, Tension and Suspension Materials, Telecommunication Transmission Line Materials, Manufacture of Electrical Panel Boards, Electric Vehicle Charging Station Equipment and Industrial Automation Production of G-BUS.
<u>Location 1</u>	Çayırcıma Organize Sanayi 1. Nolu OSB Meydanı 1. Caddesi 6. ve 7. Sokak Çayırcıma Zonguldak, Turkey	Manufacture of Cable Trays, Ladders and Accessories, Under Floor Cable, Trays, Junction Boxes and Accessories, Mounting Materials, Platform Grids, Earthing Materials and Lighting Rod, Tension and Suspension Materials, Telecommunication Transmission Line Materials, Bus-Bar Duct and Hot Dip Galvanization, Manufacture of Electrical Panel Boards.

Approval Certificate No: IST6005522/B Original Approval: 17 March 2010  
Current Certificate: 17 March 2013  
Certificate Expiry: 16 March 2016

 Page 2/2

This document is subject to the provision on the reverse  
71 Fenchurch Street, London EC3A 4BS United Kingdom. Registration number 1879210.  
No other UKAS logo or other certification marks should be used in conjunction with this certification. For more information visit www.ukas.com



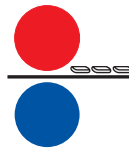

**LRQA**  
Business Assurance

**ONAY SERTİFİKASI**

Bu İş Sağlığı ve Güvenliği Yönetim Sistemi Sertifikası :

**GERSAN ELEKTRİK TİC. VE SAN. A.Ş.**  
İstanbul Anadolu Yakası Organize Sanayi Bölgesi Gazi Bulvarı  
No: 39-41 34953 Tuzla  
İSTANBUL-TÜRKİYE

firmasının İş Sağlığı ve Güvenliği Yönetim Sistemi'nin Lloyd's Register Quality Assurance Limited tarafından onaylandığının belgesidir. Bu sertifika aşağıda belirtilen standartlar için geçerlidir

**OHSAS 18001:2007**

İş Sağlığı ve Güvenliği Yönetim Sistemi'nin kapsamı

**Kablo Kanalı, Merdiveni ve Aksesuarları, Döşeme Altı Kablo Kanalı, Buatı ve Aksesuarları, Topraklama Malzemeleri ve Paratoner Bağlantı Elemanları, Platform İzgaraları, Aski, Gergi Takımları, Telefon Nakil Hattı Hırdavat Malzemeleri, Busbar Kanal Üretimi ve Sıcak Daldırma Galvanizleme, Elektrik Dağıtım Panolarının İmalatı, Elektrikli Araç Şarj Sistemleri ve G-BUS Endüstriyel Otomasyon Sistemi İmalatı**

Bu sertifika, sadece onay verilen sahaların listelendiği ve üzerinde aynı sertifika onay numarasını taşıyan sertifika eki ile birlikte geçerlidir.

Sertifika Onay No : IST6005522/C	İlk onay: 24 Nisan 2012
	Şimdiki sertifika: 17 Mart 2013
	Geçerlilik süresi: 16 Mart 2016

Lloyd's Register Quality Assurance Limited adına  
Lloyd's Register Gözetim Ltd Şti. tarafından verilmiştir.

1/2

No addition or deletion of scope is permitted without the written consent of Lloyd's Register Quality Assurance Limited. This document is subject to the provisions on the reverse.

**LRQA**  
Business Assurance

**ONAY SERTİFİKASI**

<u>Lokasyon</u>	<u>Adres</u>	<u>Kapsam</u>
<u>Merkez Ofis</u>	İstanbul Anadolu Yakası Organize Sanayi Bölgesi Gazi Bulvarı No: 39-41 34953 Tuzla İstanbul, Türkiye	Kablo Kanalı, Merdiveni ve Aksesuarları, Döşeme Altı Kablo Kanalı, Buatı ve Aksesuarları, Topraklama Malzemeleri ve Paratoner Bağlantı Elemanları, Aski, Gergi Takımları, Telefon Nakil Hattı Hırdavat Malzemeleri Üretimi, Elektrik Dağıtım Panolarının İmalatı, Elektrikli Araç Şarj Sistemleri ve G-BUS Endüstriyel Otomasyon Sistemi İmalatı
<u>Lokasyon1</u>	Çayyuma Organize Sanayi 1. Nolu OSB Meydanı 1. Cadde 6. ve 7. Sokak Çayyuma Zonguldak, Türkiye	Kablo Kanalı, Merdiveni ve Aksesuarları, Döşeme Altı Kablo Kanalı, Buatı ve Aksesuarları, Topraklama Malzemeleri ve Paratoner Bağlantı Elemanları, Platform İzgaraları, Aski, Gergi Takımları, Telefon Nakil Hattı Hırdavat Malzemeleri, Busbar Kanal Üretimi ve Sıcak Daldırma Galvanizleme, Elektrik Dağıtım Panolarının İmalatı

Sertifika Onay No : IST6005522/C	İlk onay: 24 Nisan 2012
	Şimdiki sertifika: 17 Mart 2013
	Geçerlilik süresi: 16 Mart 2016

Lloyd's Register Quality Assurance Limited adına  
Lloyd's Register Gözetim Ltd Şti. tarafından verilmiştir.

2/2

No addition or deletion of scope is permitted without the written consent of Lloyd's Register Quality Assurance Limited. This document is subject to the provisions on the reverse.

**LRQA**  
Business Assurance

**CERTIFICATE OF APPROVAL**

This is to certify that the Occupational Health & Safety Management System of:

**GERSAN ELEKTRİK TİC. VE SAN. A.Ş.**  
İstanbul Anadolu Yakası Organize Sanayi Bölgesi Gazi Bulvarı  
No: 39-41 34953 Tuzla  
İSTANBUL-TURKEY

has been approved by Lloyd's Register Quality Assurance to the following specification:

**OHSAS 18001:2007**

The Occupational Health & Safety Management System is applicable to:

**Manufacture of Cable Trays, Ladders and Accessories, Under Floor Cable, Trays, Junction Boxes and Accessories, Mounting Materials, Platform Grids, Earthing Materials and Lighting Rod, Tension and Suspension Materials, Telecommunication Transmission Line Materials, Bus-Bar Duct and Hot Dip Galvanization, Manufacture of Electrical Panel Boards, Electric Vehicle Charging Station Equipment and Industrial Automation Production of G-BUS**

This certificate is valid only in association with the certificate schedule bearing the same number on which the locations applicable to this approval are listed.

Approval Certificate No: IST6005522/C	Original Approval: 24 April 2012
	Current Certificate: 17 March 2013
	Certificate Expiry: 16 March 2016

Issued by Lloyd's Register Gözetim Ltd Şti. for and on behalf of Lloyd's Register Quality Assurance Limited

Page 1/2

This document is subject to the provisions on the reverse.

**LRQA**  
Business Assurance

**CERTIFICATE OF APPROVAL**

<u>Location</u>	<u>Address</u>	<u>Scope</u>
<u>Head Office</u>	İstanbul Anadolu Yakası Organize Sanayi Bölgesi Gazi Bulvarı No: 39-41 34953 Tuzla İstanbul, Turkey	Manufacture of Cable Trays, Ladders and Accessories, Under Floor Cable, Trays, Junction Boxes and Accessories, Earthing Materials and Lighting Rod, Mounting Materials, Tension and Suspension Materials, Telecommunication Transmission Line Materials, Manufacture of Electrical Panel Boards, Electric Vehicle Charging Station Equipment and Industrial Automation Production of G-BUS.
<u>Location1</u>	Çayyuma Organize Sanayi 1. Nolu OSB Meydanı 1. Cadde 6. ve 7. Sokak Çayyuma Zonguldak, Turkey	Manufacture of Cable Trays, Ladders and Accessories, Under Floor Cable, Trays, Junction Boxes and Accessories, Mounting Materials, Platform Grids, Earthing Materials and Lighting Rod, Tension and Suspension Materials, Telecommunication Transmission Line Materials, Bus-Bar Duct and Hot Dip Galvanization, Manufacture of Electrical Panel Boards.

Approval Certificate No: IST6005522/C	Original Approval: 24 April 2012
	Current Certificate: 17 March 2013
	Certificate Expiry: 16 March 2016

Issued by Lloyd's Register Gözetim Ltd Şti. for and on behalf of Lloyd's Register Quality Assurance Limited

Page 3/2

This document is subject to the provisions on the reverse.



3  
TAKSİM - TÜNEL

410

410

URSLARI  
BE GİTTİMİZ

EGİTİMİN  
RATVİ

HEİTS

M